

3/16" TAPCON WITH A
MIN. 1-1/4" MIN. EMBEDMENT
SEE ELEVATION FOR
ANCHOR SPACING.

10 F.H. S.M.S. WITH A
MIN. 1-1/2" MIN. EMBEDMENT
SEE ELEVATION FOR
ANCHOR SPACING.

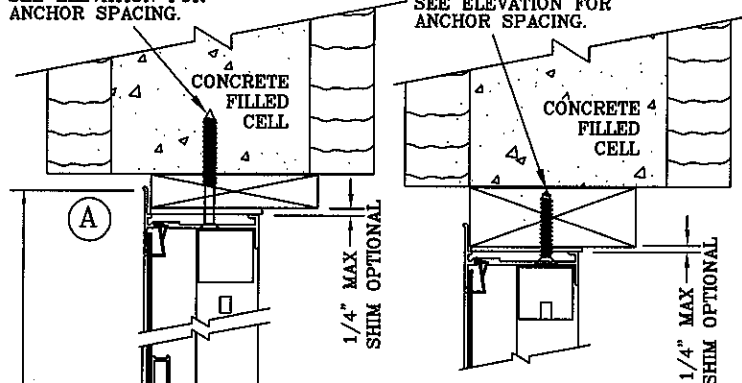

ALT. HEADER SECTION
TYP. 2 BY BUCK

3/16" TAPCON
W/1-1/4" MIN. EMBEDMENT
SEE ELEVATION FOR
ANCHOR SPACING.

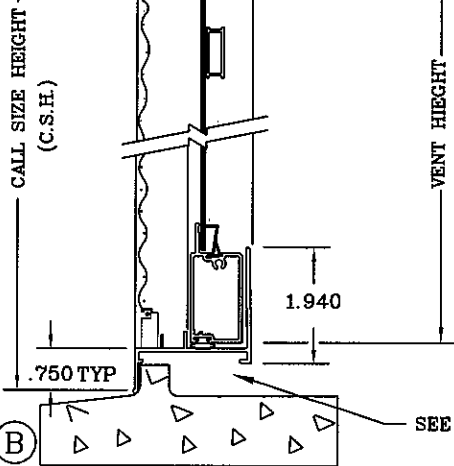

HEADER AND SILL SECTION
TYP. 1 BY BUCK

- NOTES:
- 1) SHIMS ARE OPTIONAL, MAX SHIM STACK 1/4".
 - 2) ALL ALUMINUM EXTRUSIONS ARE ALLOY 6063-T5 OR T6 WITH TYPICAL WALL THICKNESS OF 0.062".
 - 3) USE HIGH QUALITY CAULK BEHIND WINDOW FLANGE.
 - 4) GLASS THICKNESS BASED ON ASTM E 1300 GLASS CHARTS, AND MAY VARY DEPENDING ON SIZE.
 - 5) THE RESPONSIBILITY FOR SELECTION OF NORANDEX PRODUCTS TO MEET ANY APPLICABLE LOCAL LAWS, BUILDING CODES, ORDINANCES OR OTHER SAFETY REQUIREMENTS REST SOLELY WITH THE ARCHITECT, BUILDING OWNER OR CONTRACTOR.
 - 6) A PRESSURE TREATED WOODEN BUCK OR MARBLE SILL SHALL BE ADDED UNDER THE PRODUCT TO FULLY SUPPORT UNIT. THIS SUPPORT SHALL BE FIRMLY ATTACHED INTO MASONRY AND SUPPORT THE PRODUCT OVER ITS FULL LENGTH (SUPPLIED BY OTHERS).
 - 7) CONCRETE COMPRESSIVE STRENGTH = 3,000 PSI AT 28 DAYS.
 - 8) WOOD BUCKS NOT BY NORANDEX MUST SUSTAIN IMPOSED LOADS. CONTRACTOR IS RESPONSIBLE FOR MAINTAINING STRUCTURAL INTEGRITY OF THE WINDOW OPENING AND ANY WOOD FRAMING AROUND WINDOW HEADER.

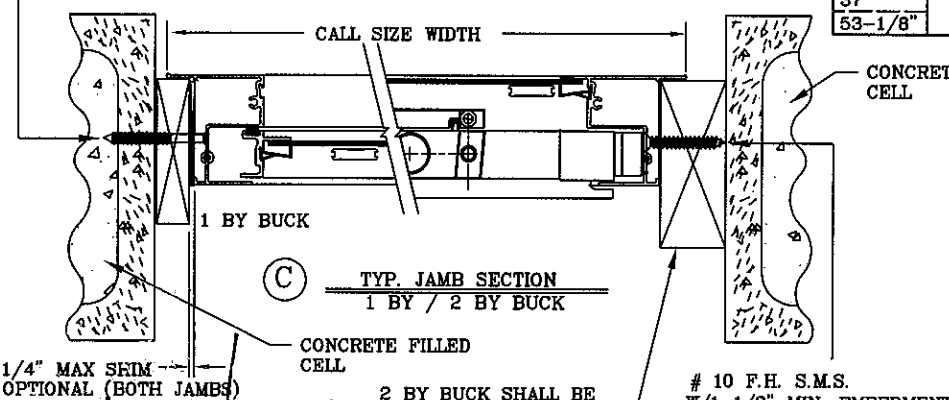

1/4" MAX SHIM
OPTIONAL (BOTH JAMBS)

10 F.H. S.M.S.
W/1-1/2" MIN. EMBEDMENT
SEE ELEVATION FOR
ANCHOR SPACING.

W.C. David
9/3/02

W.A. DAVIS, P.E.
FL. REG. ENG. # 25539
DATE: 9/3/02

WINDOW DIMENSIONS		FASTENER SCHEDULE			
WIDTH (INCHES)	HEIGHT (INCHES)	NO. ANCHORS HEAD		NO. ANCHORS JAMB	
		±35 (PSF)	±45 (PSF)	±35 (PSF)	±45 (PSF)
19-1/8"	26"	2	2	2	2
26-1/2"		2	2	2	2
37"		2	2	2	2
53-1/8"	38-1/4"	3	3	2	2
19-1/8"		2	2	3	3
26-1/2"		2	2	3	3
37"		2	2	3	3
53-1/8"	50-5/8"	3	3	3	3
19-1/8"		2	2	3	3
26-1/2"		2	2	3	3
37"	63"	2	2	3	3
53-1/8"		3	3	3	3
19-1/8"		2	2	4	4
26-1/2"		2	2	4	4
37"	76-3/4"	2	2	4	4
53-1/8"		3	3	4	4

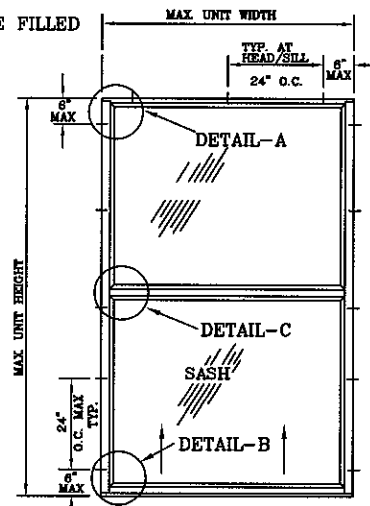

437 SINGLE HUNG
INSTALLATION DETAIL
AND
FASTENER SCHEDULE

SERIES: 437
ALUMINUM SINGLE HUNG
NORANDEX
4606 30th STREET WEST
BRADENTON, FL. 34407
PHONE: (941) 766-1581

NO. DATE	REVISIONS DESCRIPTION

DATE: 4/30/02
SCALE: N.T.S.
DWG. BY: RAF
CHK. BY:
DWG. NO.: MAR-003