

EAGLE WINDOW & DOOR

ALUMINUM CLAD STANDARD SLIDING DOOR W/NAILING FIN

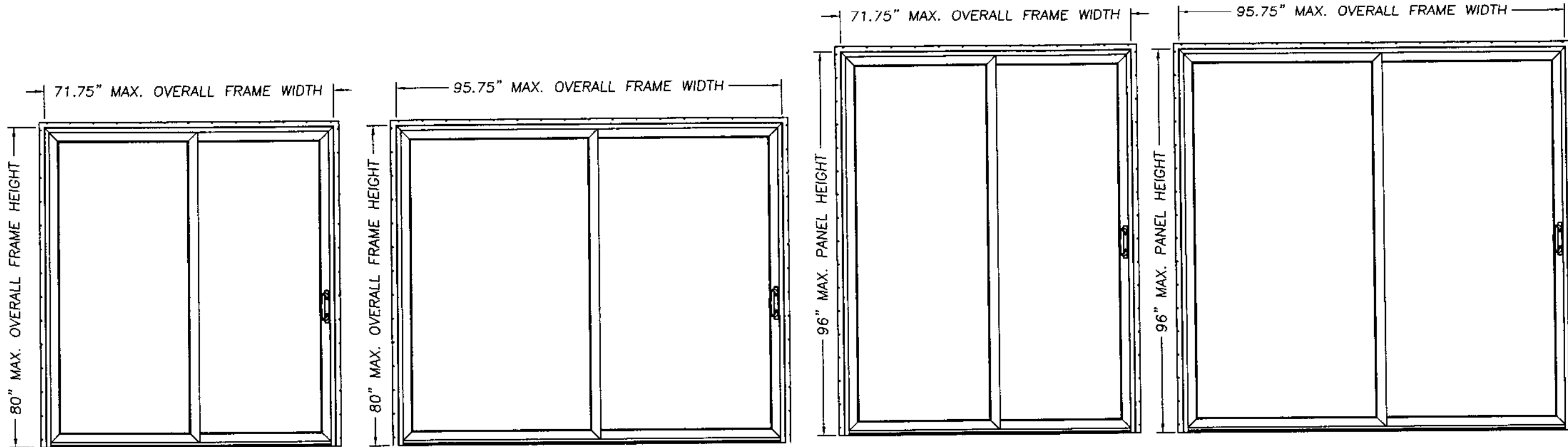

0 X

DESIGN PRESSURE RATING
POS. 40.0 NEG. 40.0

0 X

DESIGN PRESSURE RATING
POS. 30.0 NEG. 30.0

0 X

DESIGN PRESSURE RATING
POS. 33.0 NEG. 33.0

0 X

DESIGN PRESSURE RATING
POS. 25.0 NEG. 25.0

GENERAL NOTES

1. THIS PRODUCT IS DESIGNED TO COMPLY WITH THE FLORIDA BUILDING CODE.
2. PRODUCT ANCHORS SHALL BE AS LISTED AND SPACED AS SHOWN ON DETAILS.
3. WHEN THIS PRODUCT IS USED IN AN AREA REQUIRING WINDBORNE DEBRIS PROTECTION, FLORIDA BUILDING CODE APPROVED IMPACT RESISTANT SHUTTERS ARE REQUIRED.
4. ANCHORING FOR A 2x BUCK TO MASONRY WITH NAILING FIN INSTALLATION SEE SHEET 2 OF 3.
5. ANCHORING FOR WOOD STUD CONSTRUCTION WITH NAILING FIN INSTALLATION SEE SHEET 3 OF 3.

PRODUCT DESCRIPTION

1. ALUMINUM CLAD PONDEROSA PINE SLIDING DOOR WITH BLIND MORTISE AND TENON CORNERS.
2. THE HEAD AND SIDE JAMBS ARE ALUMINUM CLAD PONDEROSA PINE WITH MITER CORNERS.
3. THE THRESHOLD IS A SLOPED EXTRUDED FIBERGLASS SILL.
4. THE GLASS IS 3/4" OVERALL, CONSISTING OF TWO LITES OF 1/8" TEMPERED GLASS AND IS GLAZED WITH FOAM TAPE AND WOOD GLAZING STOPS.
5. ALL UNITS UTILIZE AN EXTRUDED PVC NAILING FIN WHICH IS PRESS FIT INTO THE FRAME.

Lyndon F. Schmidt
September 24, 2002

Lyndon F. Schmidt
Florida P. E. No. 43409
19506 French Lace Drive Lutz, FL 33558

EAGLE WINDOW & DOOR, INC.
2045 KERPER BOULEVARD
DUBUQUE, IA 52004-1072
PH. 319.556.4408

PRODUCT:	GENERAL NOTES & TYPICAL ELEVATIONS EAGLE WINDOW & DOOR PART OR ASSEMBLY: ALUMINUM CLAD STANDARD SLIDING DOOR		
NO.	DATE	BY	REVISIONS

RW BUILDING CONSULTANTS, INC.
813.659.9197

DATE: 09/23/02
SCALE: N.T.S.
DWG. BY: WLN
CHK. BY: RW
DRAWING NO.: EGL-105-OCF
SHEET 1 OF 3

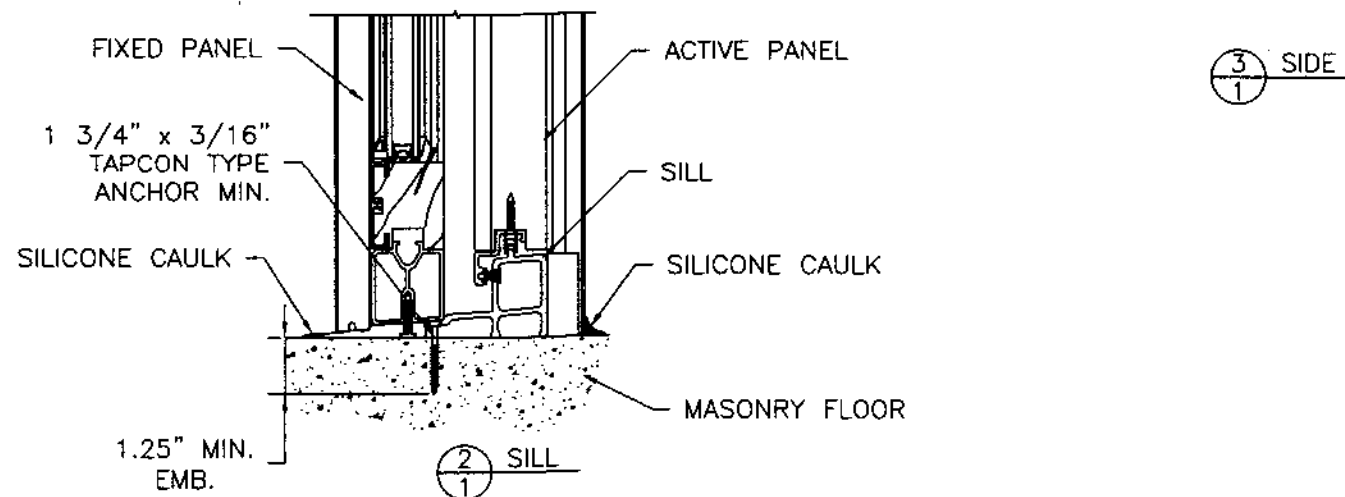
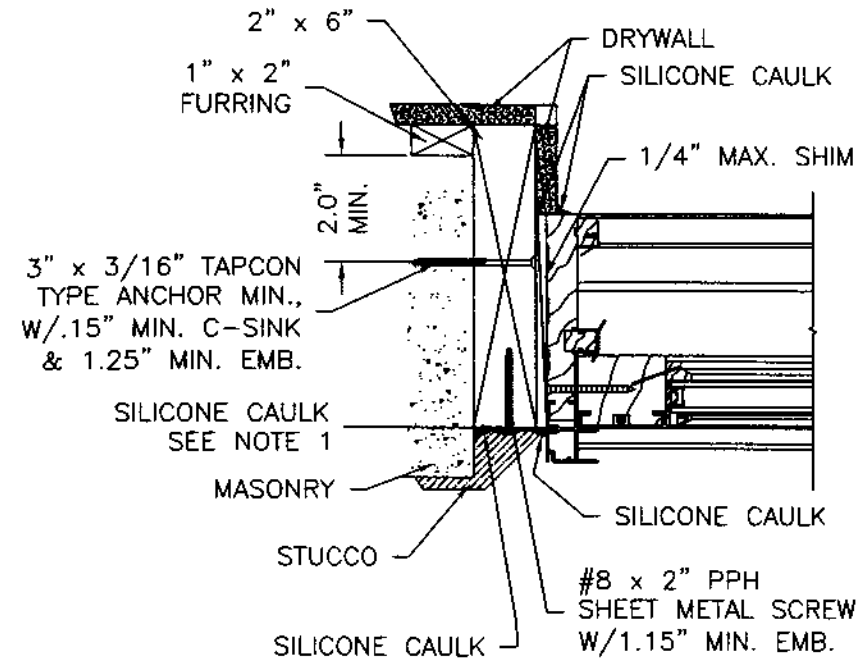
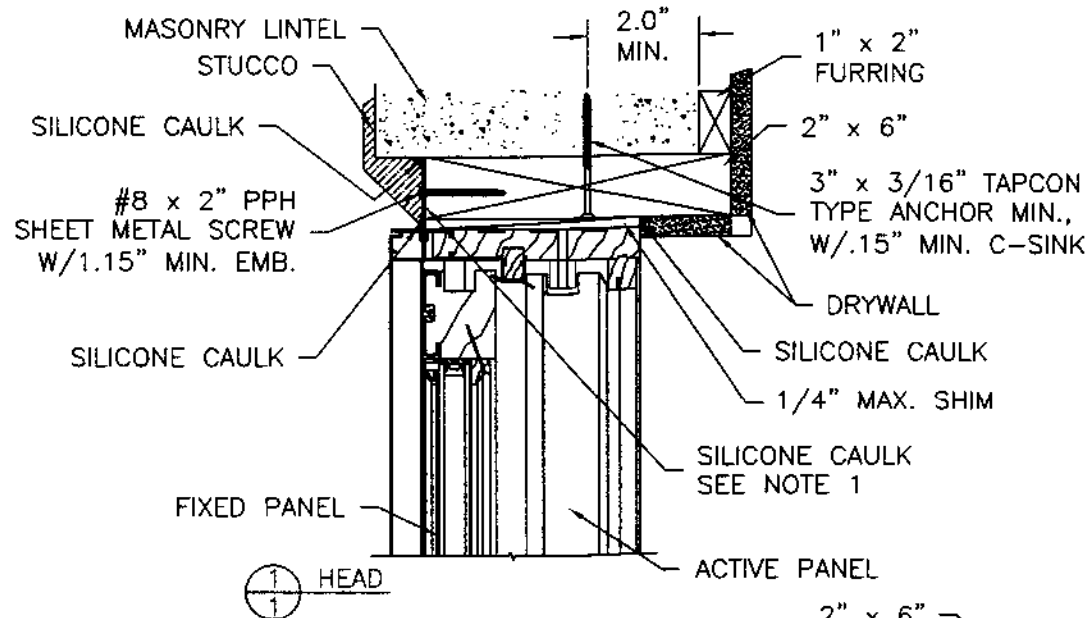
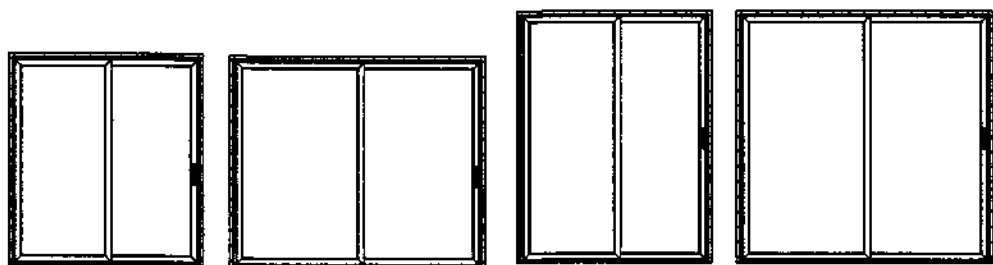
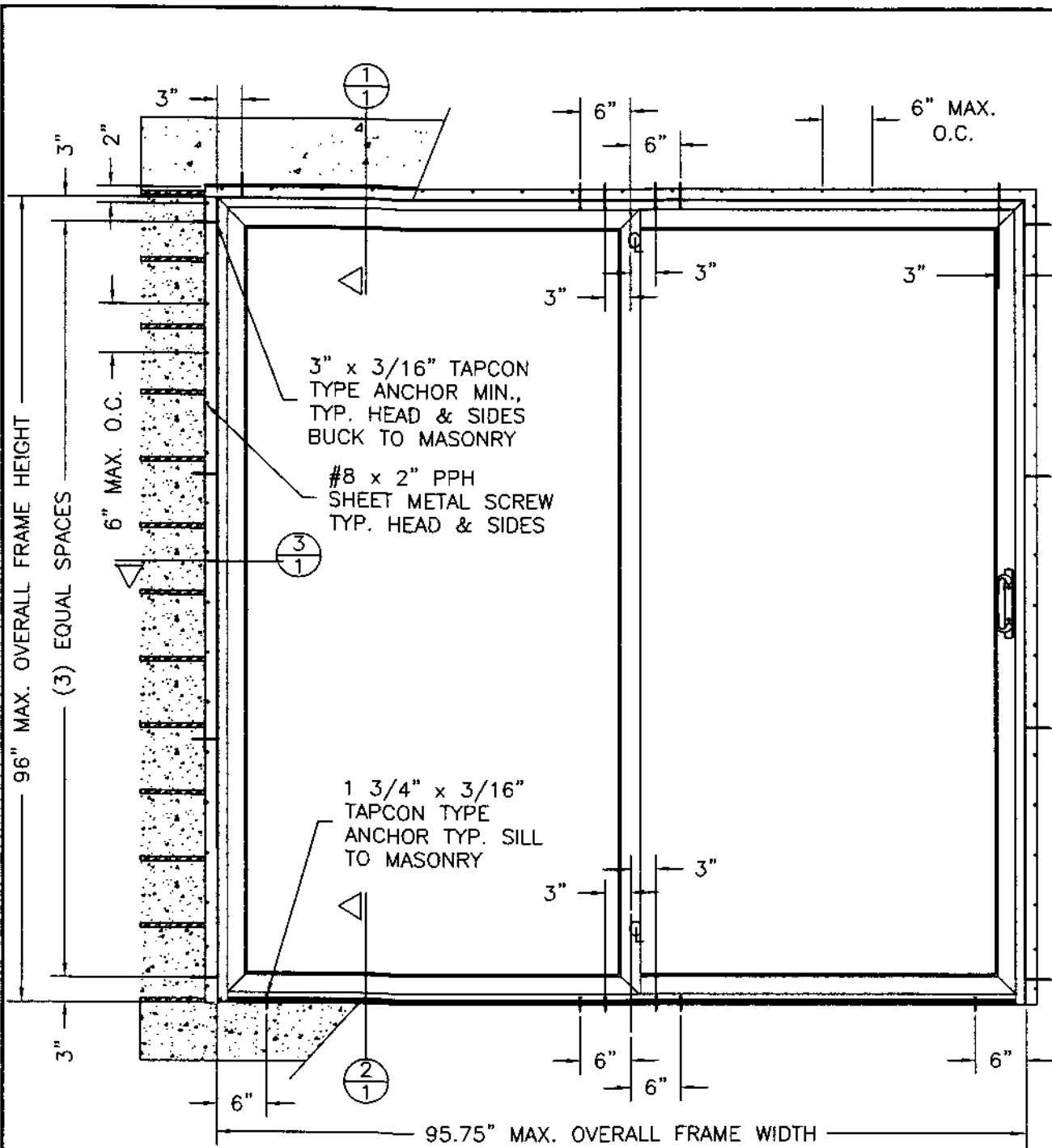

NOTES:

1. The full perimeter of the window nailing flange must have a heavy bead of caulk applied to the building side before the window is placed in the opening.
2. Adjust Tapcon anchor locations, if necessary, to maintain a minimum 2.0" clearance from mortar joints.

September 24, 2002
 Lyndon F. Schmidt
 Florida P.E. No. 43409
 19506 French Lake Drive
 Lutz, FL 33558

EAGLE WINDOW & DOOR, INC.
 2045 KERPER BOULEVARD
 DUBUQUE, IA 52004-1072
 PH. 319.556.4408

ANCHORING CROSS SECTIONS
 FOR 2X BUCK TO MASONRY
 ALUMINUM CLAD WOOD
 STANDARD SLIDING DOOR

RW BUILDING CONSULTANTS, INC.
 813.659.9197

DATE: 09/23/02

SCALE: N.T.S.

DWG. BY: TJH

CHK. BY: RW

DRAWING NO.:

EGL-105-OCF

SHEET 2 OF 3

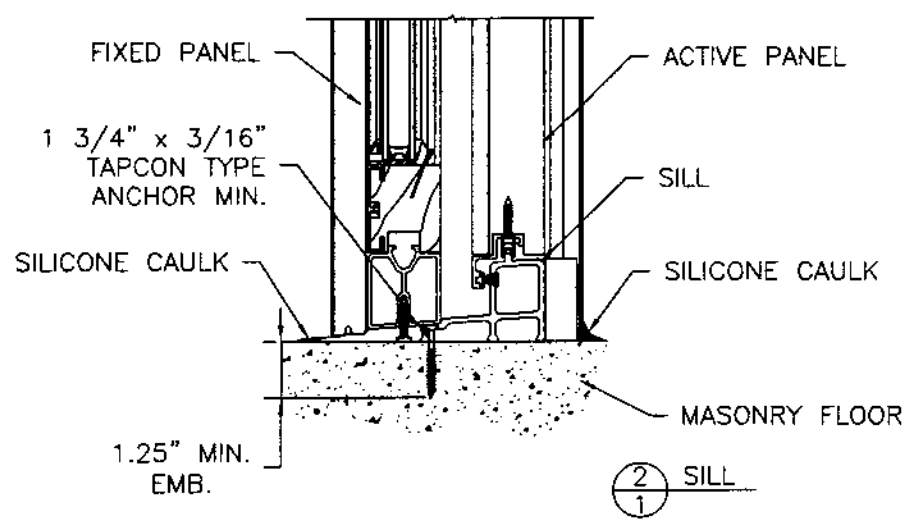
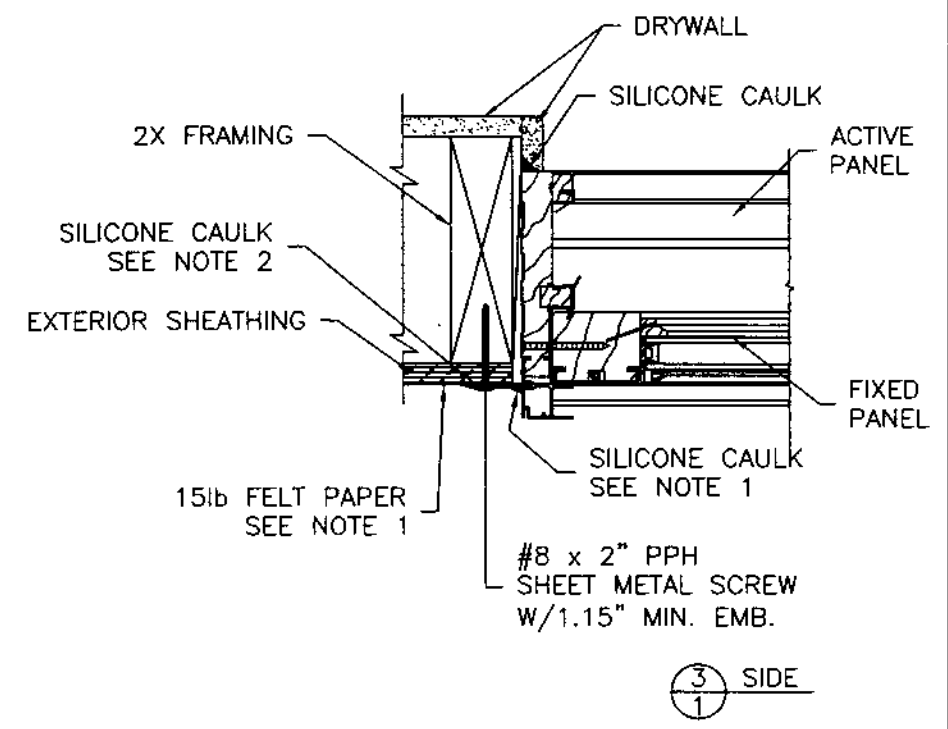
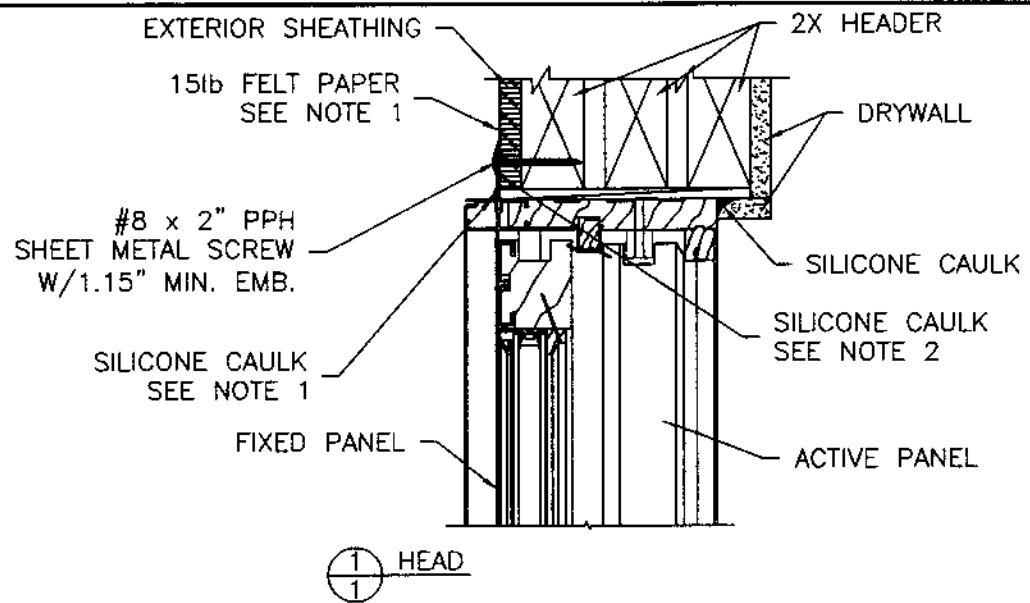
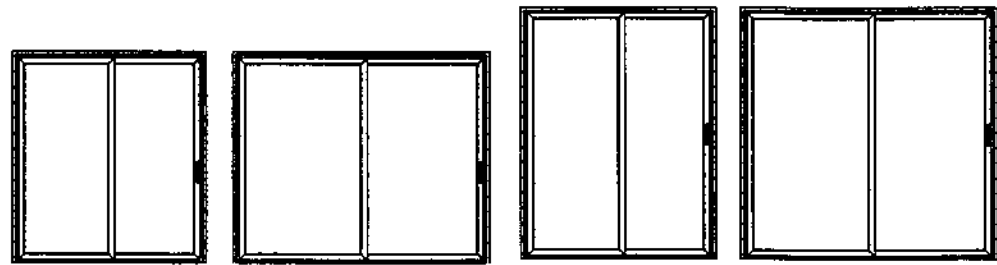
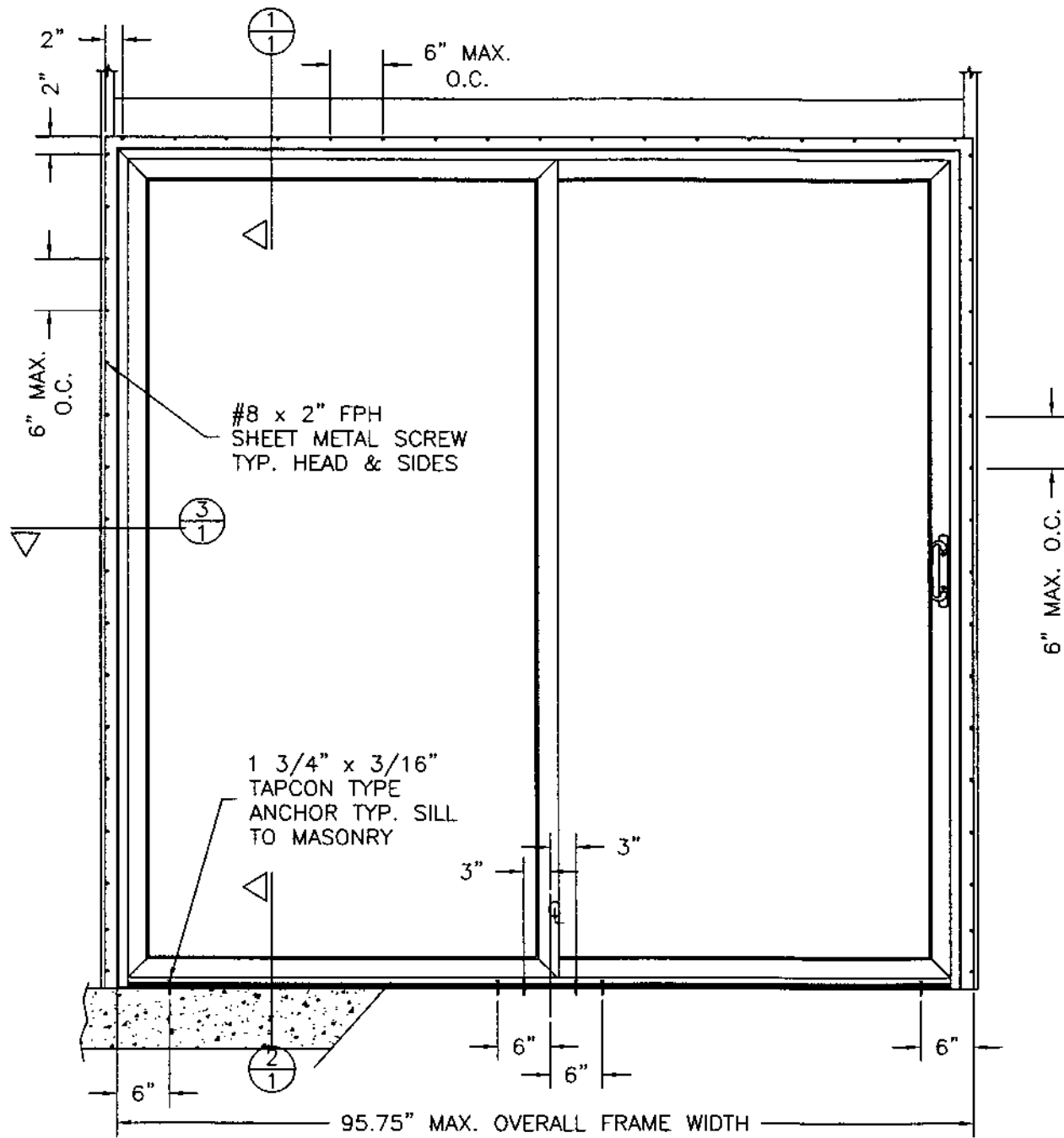

September 24, 2002
 Lyndon E. Schmidt
 Florida P.E. No. 43409
 19506 French Lace Drive
 Lutz, FL 33558

EAGLE WINDOW & DOOR, INC.
 2045 KERPER BOULEVARD
 DUBUQUE, IA 52004-1072
 PH. 319.556.4408

ANCHORING CROSS SECTIONS
 FOR WOOD CONSTRUCTION
 ALUMINUM CLAD WOOD
 STANDARD SLIDING DOOR

RW BUILDING
 CONSULTANTS, INC.
 813.659.9197

DATE: 09/23/02
 SCALE: N.T.S.
 DWG. BY: TJH
 CHK. BY: RW
 DRAWING NO.: EGL-105-OCF
 SHEET 3 OF 3

- NOTES:**
- 15lbs. felt must be used as a water barrier. The felt must cover the nailing fin and anchor screw heads. All loose edges of the felt paper must be sealed with silicone caulk.
 - The full perimeter of the window nailing fin must have a heavy bead of caulk applied to the building side before the window is placed in the opening.