

CERTIFIED TESTING LABORATORIES

Architectural Division • 7252 Narcoossee Rd. • Orlando, FL 32822

(407) 384-7744 • Fax (407) 384-7751

Web Site: www.ctlarch.com

E-mail: ctlarch.com

Report Number: CTLA-184W-3-A

Report Date: August 8, 1997

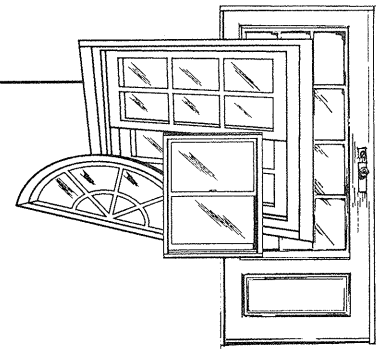

STRUCTURAL PERFORMANCE TEST REPORT

Client: BINNINGS PAN AMERICAN
2805 N. E. 185TH STREET
MIAMI, FLORIDA 33180

Product Type and Series: Series PA 551 Extruded Aluminum Single Hung SH-R35 53" x 74"
Equal Lite

Test Specifications: AAMA / NWWDA 101/I.S. 2-97 "Voluntary Specifications for Aluminum, Vinyl, (PVC) and Wood Windows and Glass Doors"

TEST SPECIMEN

Frame: The aluminum flange frame measured 53.125" x 74.188" and was coped corner construction utilizing one (1) #8 x 1" P.P., S.M.S. at each frame corner. The fixed interlock rail was fastened with two (2) #8 x 1" P.P. S.M.S. into each frame jamb.

Ventilator: One (1) wet glazed, clear light opening 50.188" x 34" and one (1) active sash measuring 50" x 37.125" with coped corners fastened with one (1) #8 x 1" P.P., S.M.S. at each corner.

Weatherstripping: A single strip of center fin weatherstrip .190" high was located on the exterior of the frame sill center leg, the interior of the fixed meeting rail and the exterior of both sash vertical stiles.

Hardware & Location: Two (2) spiral balances, one (1) balance clip was located on the bottom end of each sash stile. One (1) balance guide located on each upper interior jamb track. Two (2) sweep locks located 8" from each end of the sash interlock rail, locking into a groove in the fixed interlock. Two (2) vent top guides and two (2) vent bottom guides were located on the sash vent stiles. One (1) rubber vent stop was located on each upper, interior jamb track.

Glazing: The fixed lite and active sash were exterior glazed with 3/16" annealed glass, adhesive back bedding and an extruded aluminum glazing bead.

Sealant: A narrow joint seam sealer was used on all frame joints and fasteners.

[Handwritten signature]
4/16/00

Weepsystem: A weep notch 1.00" long x leg height was located on each end of the exterior screen channel leg and a weep notch .500" long x leg height was located on each end of the sash channel center leg of the sill.

Muntins: N/A

Reinforcements: N/A

Additional Description: N/A

Screen: The aluminum screen measured 50.625" x 31.250" and was miter cut and fastened at the corners with plastic keys. Fiberglass mesh and vinyl spline. Two (2) retainer springs and two (2) pull tabs.

Installation: The aluminum frame was fastened to the wooden test buck using eleven (11) #10 x 1.250" P.H., P.H., S.M.S. Three (3) in the head 4.5" from each corner and at mid-span. Four (4) in each jamb, measuring down from head 5", 16", 38", and 67".
See attached diagram.

Surface Finish: Mill Finish

Comment: Nominal 2 mil polyethylene film was used to seal against air leakage during structural loads. The film was used in a manner that did not influence the test results.

Performance Test Results

<u>Paragraph No.</u>	<u>Title of Test</u>	<u>Method</u>	<u>Measured</u>	<u>Allowed</u>
2.1.2	Air Infiltration @1.57 psf	ASTM E283-91	.03 cfm/ft ²	.3 cfm/ft ²

The tested specimen meets or exceeds the performance levels specified in AAMA/NWWDA 101/I.S.2-97. Results recorded in two decimals at the clients request.

2.1.3/4.3	Water Resistance @5.25 psf 5 gph/ft ²	ASTM E547 Tested with and without insect screen.	No Entry	No Entry
2.1.4.2/4.4.2	Uniform Load Structural Permanent Deformation @52.5 psf Positive @52.5 psf Negative	ASTM E330-90	.021" .150"	.204" .204"
2.1.8	Forced Entry Resistance Test A Test B Test C Test D, E and F Test G	AAMA 1302.5-76	0" 0" 0" 0" 0"	1/2" 1/2" 1/2" 1/2" 1/2"
2.2.1.6.1	Operating Force	AAMA/NWWDA 101/I.S.2-97	30 lbs	30 lbs.

4/16/02

Performance Test Results

<u>Paragraph No.</u>	<u>Title of Test</u>	<u>Method</u>	<u>Measured</u>	<u>Allowed</u>
2.2.1.6.2	Deglazing	ASTM E987-88		
	Top Rail	70 lbs.	.058"=	15.4%<100%
	Bottom Rail	70 lbs.	.041"=	10.9%<100%
	Left Stile	50 lbs.	.031"=	8.2 %<100%
	Right Stile	50 lbs.	.025"=	6.6%<100%

Test Date: August 2, 1997

Test Completion Date: August 2, 1997

Remarks: Detailed drawings were available for laboratory records and comparison to the test specimen at the time of this report. A copy of this report along with representative sections of the test specimen will be retained by CTL for a period of four (4) years. The results obtained apply only to the specimen tested.

This test report does not constitute certification of this product, but only that the above test results were obtained using the designated test methods and they indicate compliance with the performance requirements (paragraphs as listed) of the above referenced specifications.

Certified Testing Laboratories assumes that all information provided by the client is accurate and that the physical and chemical properties of the components are as stated by the manufacturer.

All Tests Witnessed by:

Ken Pangborn Binning Pan American
Chris Bennett CTL

Certified Testing Laboratories, Inc.

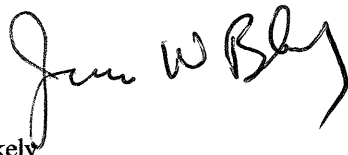

James W. Blakely
Vice President

cc Binnings Pan American (2)
ALI (2)
Ramesh Patel, P.E.
File

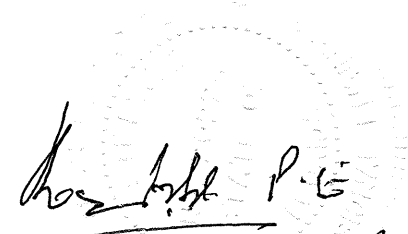

Ramesh Patel, P.E.
Florida Reg. #20224

4/15/02

CERTIFIED TESTING LABORATORIES

Architectural Division • 7252 Narcoossee Rd. • Orlando, FL 32822
(407)-384-7744 • Fax (407)-384-7751

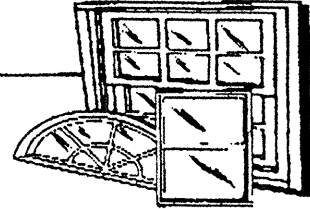

Fastener Locations

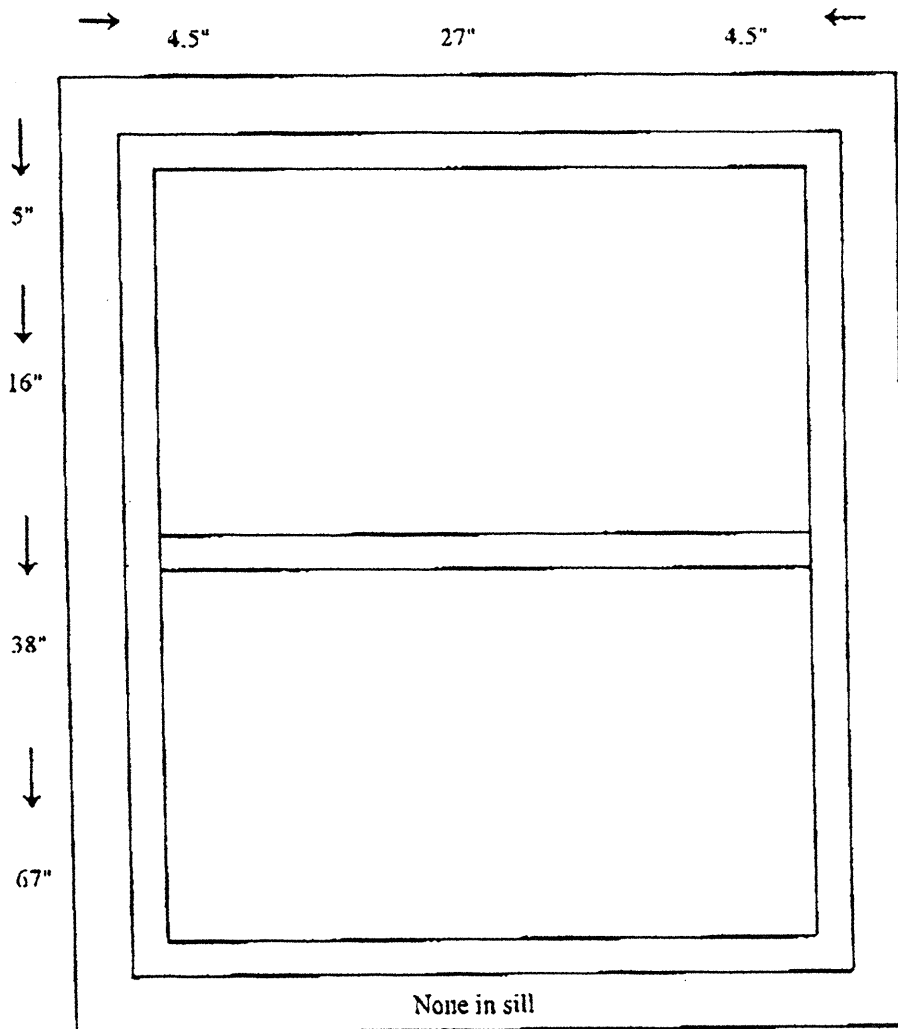

Binning Pan American
Series PA 551
Flange Frame Single Hung
CTLA-184W-3-A
August 8, 1997

#10 x 1.250" P.H., P.H.
S.M.S. Into wooden test buck

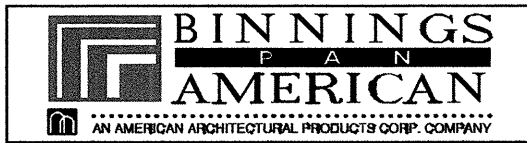

3000 N.W. 125th Street
 Miami, Florida 33167
 (305) 681-0045
 Web Site: www.Binnings.com

SERIES PA-55 | SINGLE HUNG WINDOW

Anchors at head, sill, or jamb:

Use #10 wood screws or 3/16" Tapcons.

Anchors to engage 2" by wood bucks with a 1 1/4" Min. embedment.

Anchors to engage 1" by wood bucks and masonry with a 1 1/4" Min. embedment.

Anchors to engage concrete with a 1 1/2" Min. embedment.

Connection to wood buck:

Material (buck type) = Assume Southern Pine.

$$\text{Table 11.3 from Wood Screw manual} = \text{Allowable shear} = 171 \text{ lbs.} \times 1.33 \text{ for windload} = 228 \text{ lbs.} \quad \underline{\text{Max.}}$$

$$W < 228$$

W = Load per anchor

Connection to masonry thru wood buck:

Since anchor engages 1" by wood buck and masonry, use same values as above.

Calculations for 3/16" Tapcon.

Bending on cantilever portion of anchor:

3/16" Tapcon 0.188 dia.

Material: AISI 1021 or 1022 heat treated

$$F_y = 92,000 \text{ psi}$$

$$F_u = 120,000 \text{ psi}$$

Bending:

$$F_b = .75 * F_y * 1.333 = (\text{psi})$$

$$S = .098 * D^3 = (\text{in.}^3)$$

Moment arm L = Cantilever on unsupported anchor

$$M = PL = (\text{in.} - \text{lb.})$$

$$f_b = M/S = (\text{psi}) < F_b$$

Shear:

$$F_v = .17 * F_u * 1.333 = (\text{psi})$$

$$A = 0.094^2 * \pi = (\text{psi})$$

$$f_v = P/A = 84 / 0.028 = (\text{psi}) < F_v$$

Combined Bending and Shear:

$$(f_b / F_b) + (f_v / F_v) = < 1.000$$

ROBT. E. FISHER
 WM. M. MEYERS, P.E.
 Consulting Engineers
 9301 N.E. 8th Ave. C-300
 Miami Shores, FL 33138
 (305) 758-3117 557-4006 Fax 382-6282

[Handwritten Signature]
 FLA. 18755
 STRUCTURAL
 Date: 05/13/02

SERIES PA-55 I SINGLE HUNG WINDOW

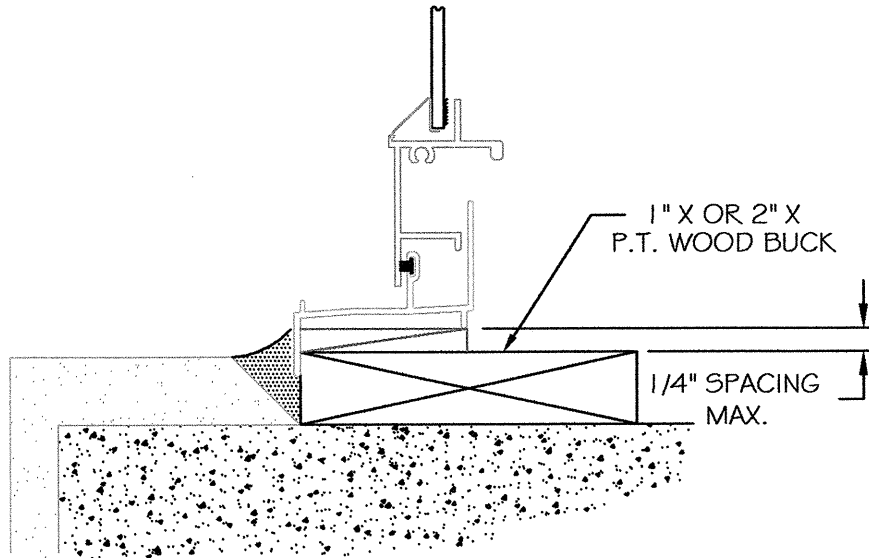

SILL INSTALLATION
(INTO WOOD)

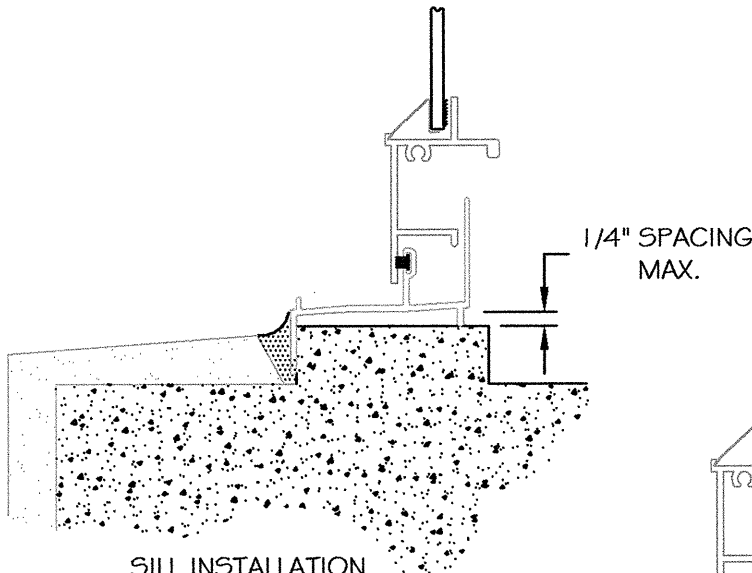

SILL INSTALLATION
(INTO CONCRETE)

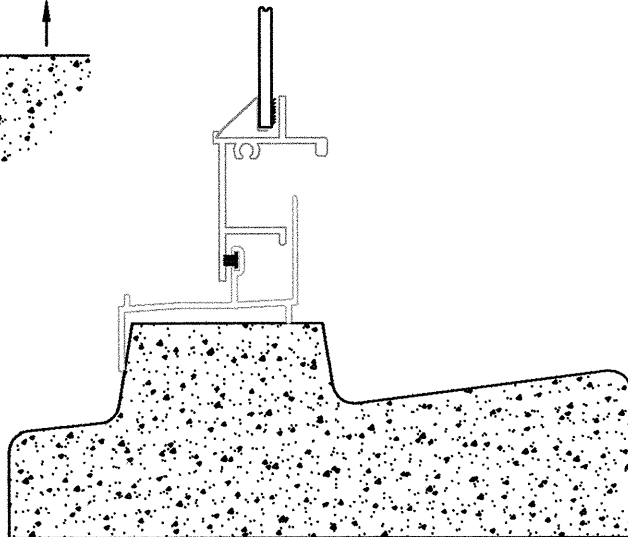

PRE-CAST SILL INSTALLATION

ROBT. E. FISHER
WM. M. MEYERS, P.E.
Consulting Engineers
9301 N.E. 2th Ave. C-800
Miami Shores, FL 33138
(305) 758-3117 Fax 305-662-6282

W. M. Meyers
FLA. 18755
STRUCTURAL

Date: 05/13/02