

STANLEY DOOR SYSTEMS®

OPAQUE WOOD EDGE / STEEL EDGE INSULATED STEEL DOOR
OUT-SWING / IN-SWING 6-8 UNITS W/ & W/OUT SIDELITES

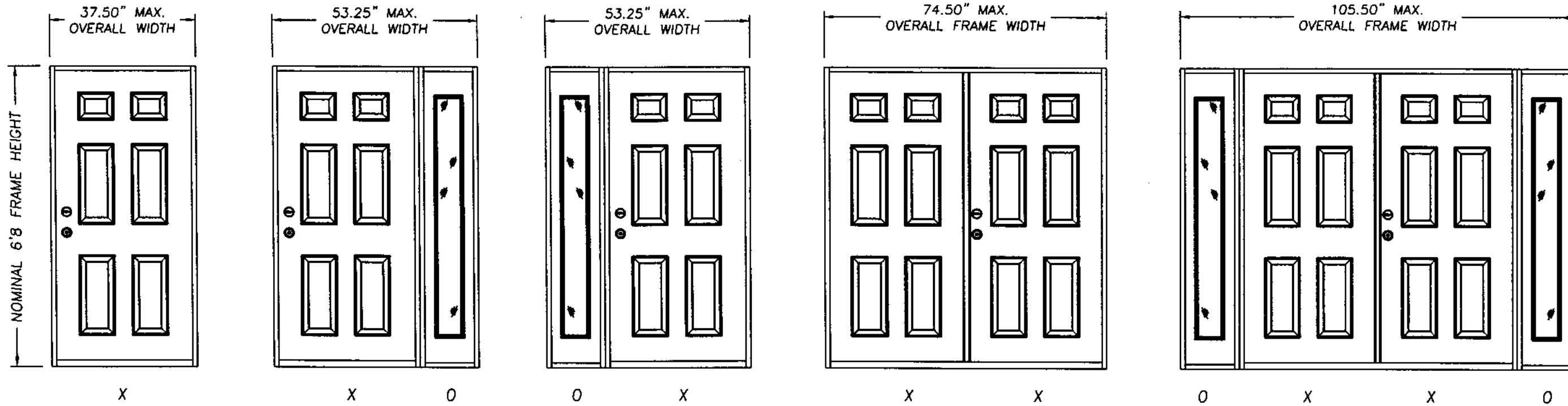

DESIGN PRESSURE RATING	
WOOD EDGE	OUT-SWING / IN-SWING POS. 55.0 NEG. 60.0
STEEL EDGE	OUT-SWING / IN-SWING POS. 70.0 NEG. 70.0

DESIGN PRESSURE RATING	
WOOD EDGE OR STEEL EDGE	OUT-SWING / IN-SWING POS. 50.0 NEG. 50.0

DESIGN PRESSURE RATING	
WOOD EDGE OR STEEL EDGE	OUT-SWING / IN-SWING POS. 50.0 NEG. 50.0

WOOD EDGE OR STEEL EDGE	ASTRAGAL TYPE	DESIGN PRESSURE RATING
	WindJamber II Mfg. by Genesis	OUT-SWING / IN-SWING POS. 55.0 NEG. 60.0
	* Alum. Astragal Mfg. by Imperial	OUT-SWING / IN-SWING POS. 44.0 NEG. 44.0

WOOD EDGE OR STEEL EDGE	ASTRAGAL TYPE	DESIGN PRESSURE RATING
	WindJamber II Mfg. by Genesis	OUT-SWING / IN-SWING POS. 50.0 NEG. 50.0
	* Alum. Astragal Mfg. by Imperial	OUT-SWING / IN-SWING POS. 44.0 NEG. 44.0

GENERAL NOTES

- THIS PRODUCT IS DESIGNED TO COMPLY WITH THE FLORIDA BUILDING CODE.
- PRODUCT ANCHORS SHALL BE AS LISTED AND SPACED AS SHOWN ON DETAILS.
- THE SIDELITES REQUIRE WINDBORNE DEBRIS EXTERNAL PROTECTION AS DESCRIBED IN SECTION 1626.1 OF THE FLORIDA BUILDING CODE WHEN USED IN WINDBORNE DEBRIS AREAS.
- FOR INSWING MASONRY ANCHORING SEE SHEET 2 OF 4.
- FOR OUTSWING MASONRY ANCHORING SEE SHEET 3 OF 4.
- FOR INSWING/OUTSWING WOOD STUD ANCHORING SEE SHEET 4 OF 4.

PRODUCT DESCRIPTION

- THE DOOR FACE SHEETS ARE 24 GA. (0.021") MIN. THICKNESS.
- WOOD EDGE DOORS, THE STILES AND RAILS ARE WOOD CONSTRUCTION WITH THE LATCH STILE BEING LVL.
- STEEL EDGE DOORS, THE STILES AND RAILS ARE A ROLLED FORMED STEEL EDGE FROM .028" THK. GALV. STEEL AND MECHANICALLY INTERLOCKED.
- THE INTERIOR DOOR CAVITY IS URETHANE.
- THE SIDELITE GLAZING IS 0.5" or 1" INSULATED TEMPERED GLASS BY ODL or TRINITY.
- THE WOOD JAMBS ARE A MIN. 4-9/16".
- THE THRESHOLD IS AN ALUMINUM BUMP FACE TYPE (OUTSWING) OR AN ALUMINUM SADDLE TYPE (INSWING).
- THE IMPERIAL ALUMINUM ASTRAGAL UTILIZES A 19.0" LONG x 0.313" DIA. STEEL ROD WITH A 1.0" WIDE x 4.5" LONG (min 2" engagement) ALUMINUM SLIDE ROD REINFORCEMENT BAR TOP AND BOTTOM.
- ALL LATCHBOLT AND DEADBOLT HARDWARE MUST BE CYLINDRICAL GRADE II WITH A 161 EDGE PREP AND A MINIMUM 1.0" DEADBOLT THROW.

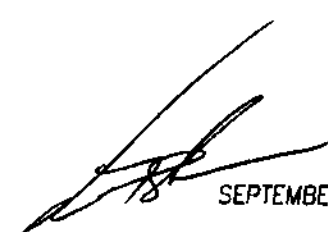
 SEPTEMBER 5, 2002
 Lyndon F. Schmidt
 Florida P. E. No. 43409
 19506 French Lace Drive Lutz, FL 33558

STANLEY

STANLEY DOOR SYSTEMS
7300 REAMES ROAD
CHARLOTTE, NC 28216
PH. (704) 921-3470

PRODUCT: WOOD EDGE / STEEL EDGE
STEEL DOOR
OPAQUE W/WO SIDELITES
PART OR ASSEMBLY:
GENERAL NOTES &
TYPICAL ELEVATIONS

NO.	DATE	BY	REVISIONS

RW BUILDING
CONSULTANTS, INC.
813.659.9197

DATE: 8/13/02
SCALE: N.T.S.
DWG. BY: WLN
CHK. BY: RW
DRAWING NO.: ST-101-OC
SHEET 1 OF 4

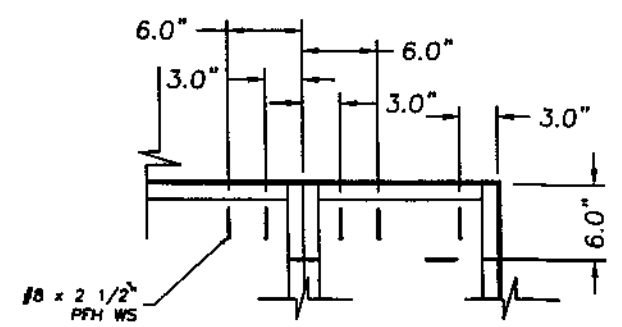
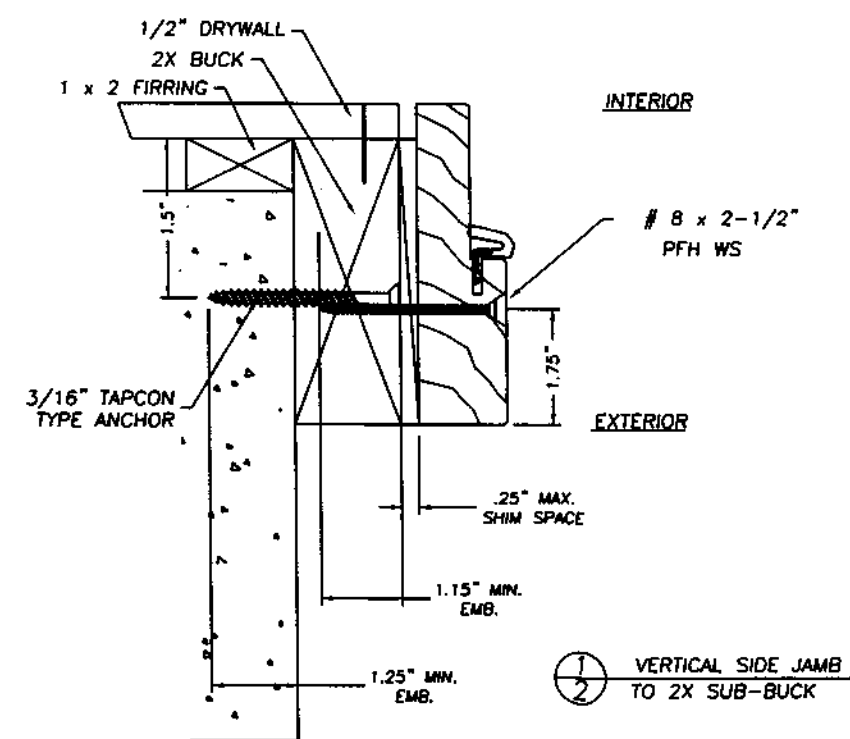
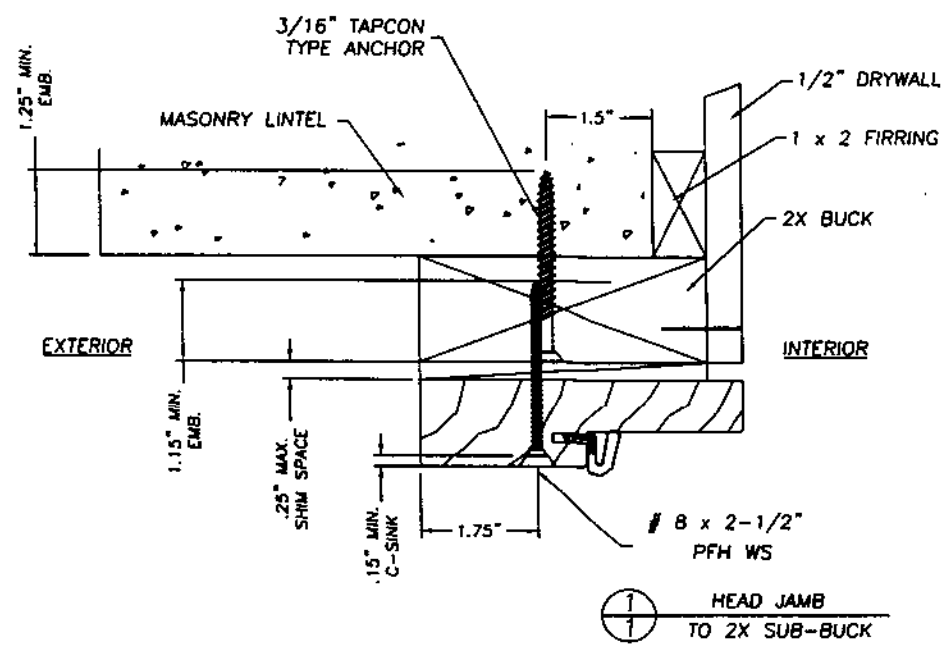

ANCHORING OF SIDELITE TO 2X BUCK

NOTE: A minimum clearance of 2.0" for all anchoring screws to mortar joints must be maintained.

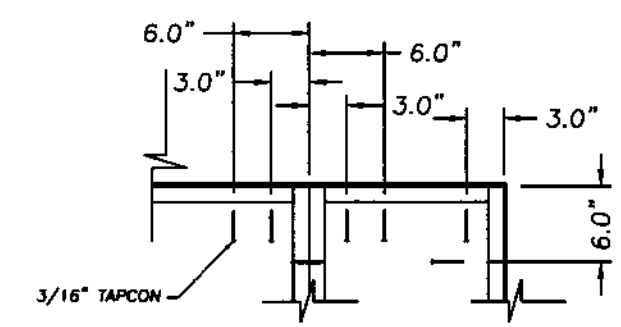
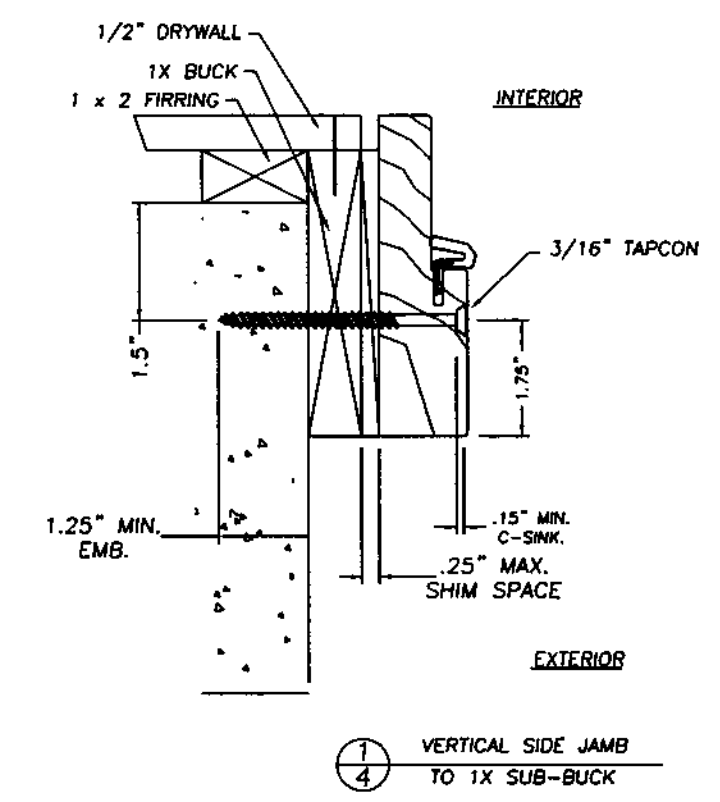
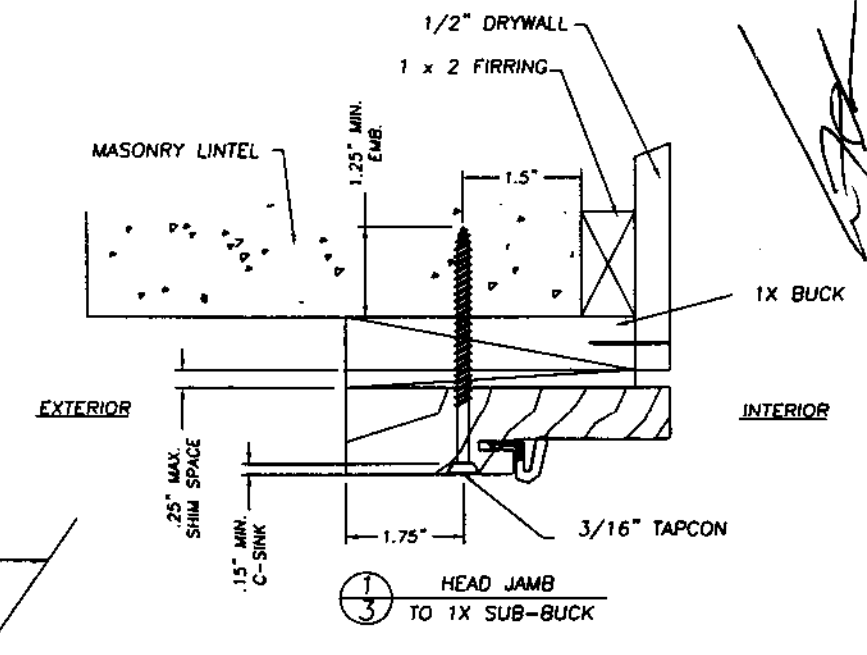
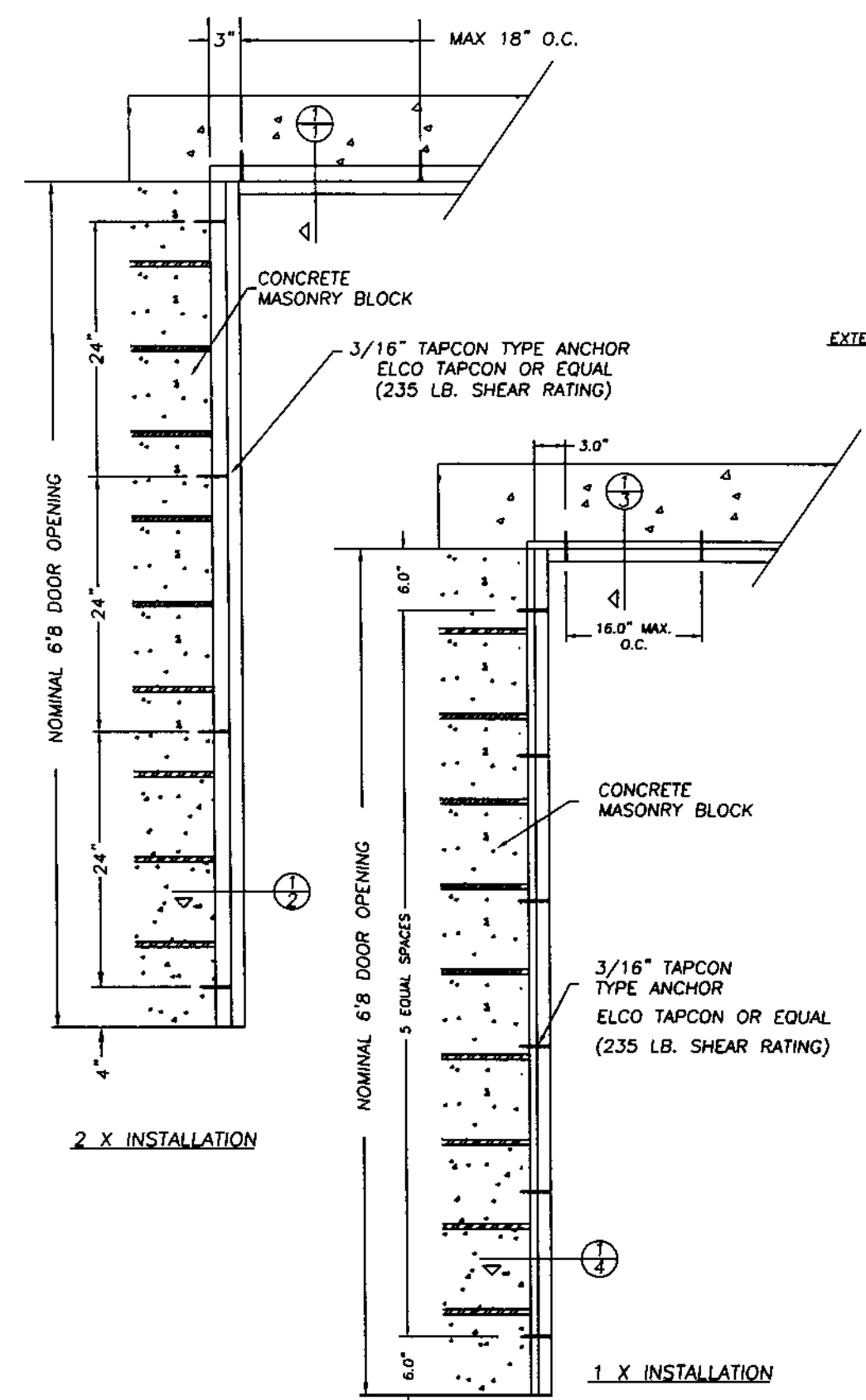

ANCHORING OF SIDELITE THROUGH 1X BUCK

SEPTEMBER 5, 2002
 Lyndon F. Schmidt
 Florida P. E. No. 43409
 19506 French Lace Drive
 Lutz, FL 33558

STANLEY
 STANLEY DOOR SYSTEMS
 7300 REAMES ROAD
 CHARLOTTE, NC 28216
 PH. (704) 921-3470

ANCHOR CROSS SECTIONS
 MASONRY 6'8
 IN-SWING WOOD FRAME

RW BUILDING
 CONSULTANTS, INC.
 813.659.9197

DATE: 8/13/02
 SCALE: NTS
 DWG. BY: WLN
 CHK. BY: RW
 DRAWING NO.: ST-101-OC
 SHEET 2 OF 4

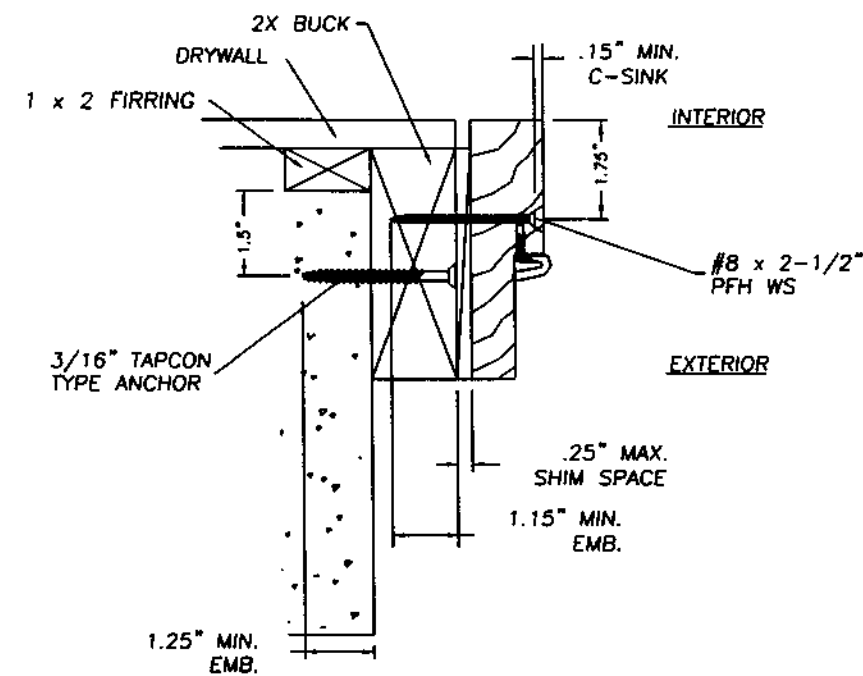
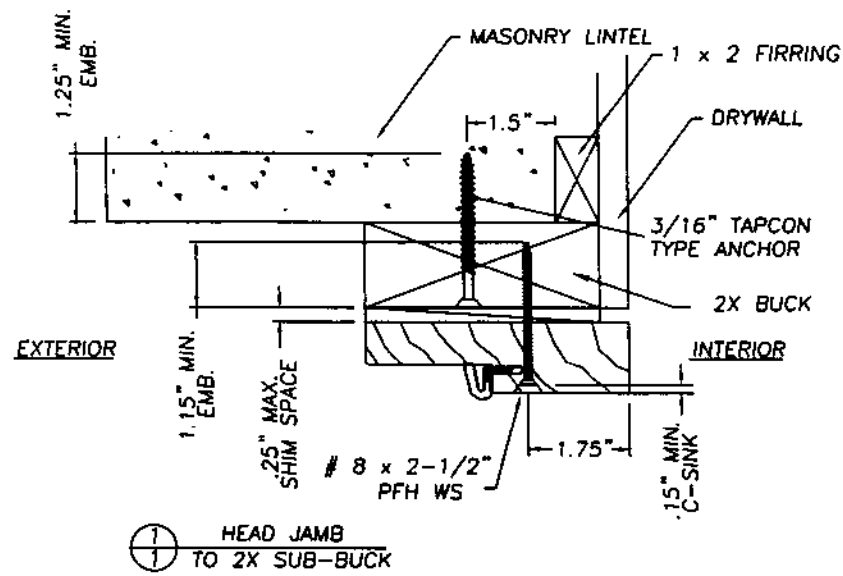

2 VERTICAL SIDE JAMB TO 2X SUB-BUCK

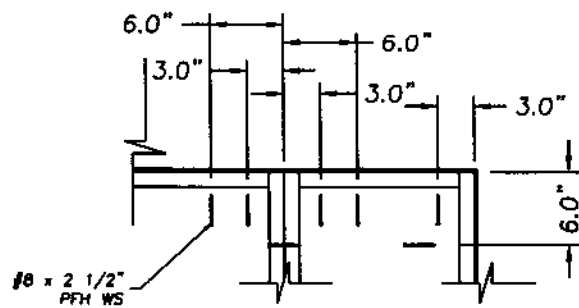

ANCHORING OF SIDELITE TO 2X BUCK

NOTE:

1. When using a 1X sub-buck a 6-9/16" jamb is required to allow for min. edge spacing for Tapcon type anchors.
2. A minimum clearance of 2.0" for all anchoring screws to mortar joints must be maintained.

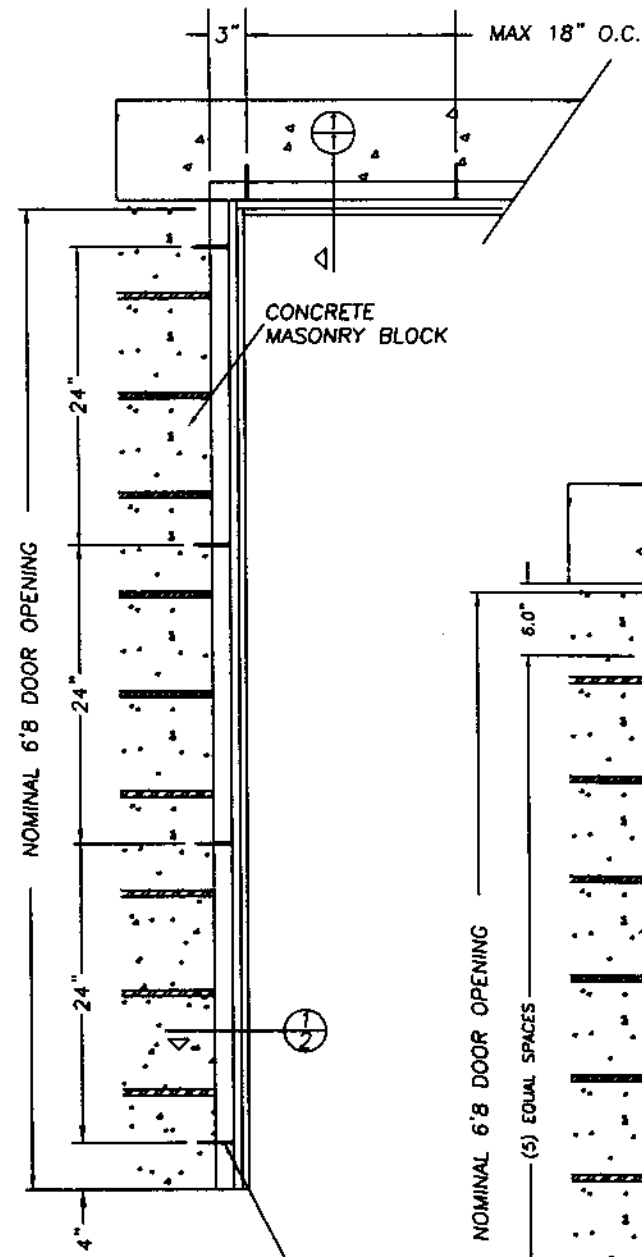

2 X INSTALLATION

3/16" TAPCON TYPE ANCHOR
ELCO TAPCON OR EQUAL
(235 LB. SHEAR RATING)

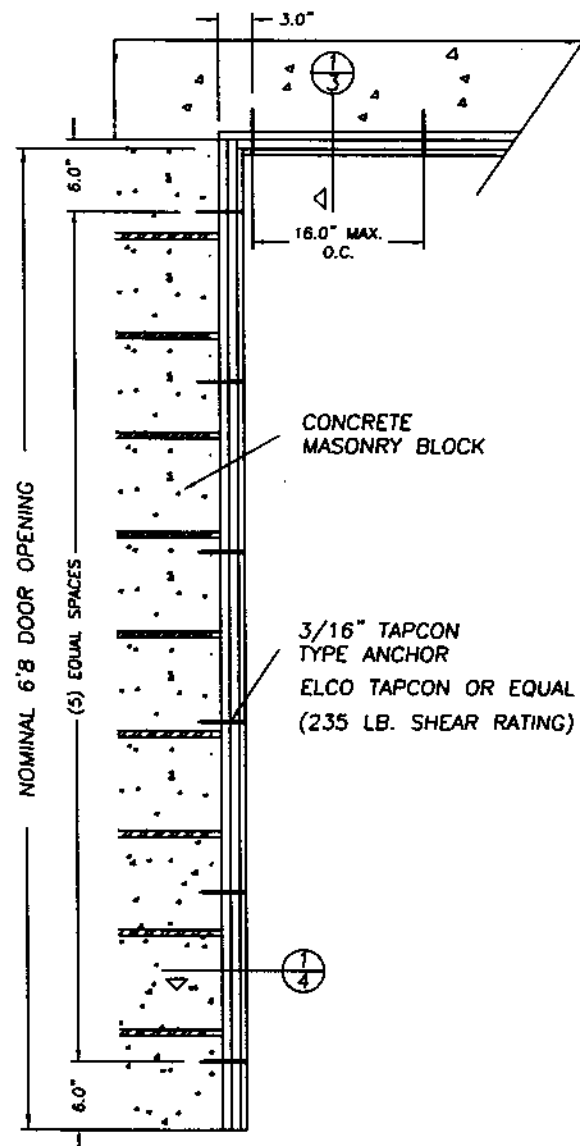

1 X INSTALLATION

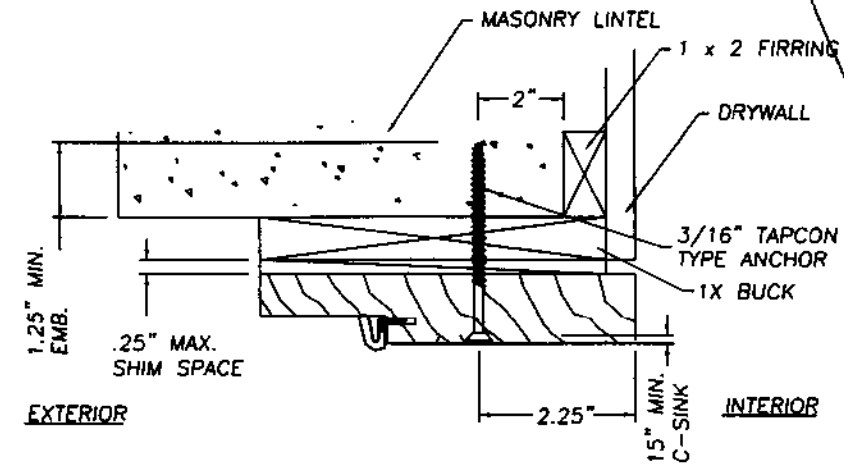

3 HEAD JAMB TO 1X SUB-BUCK

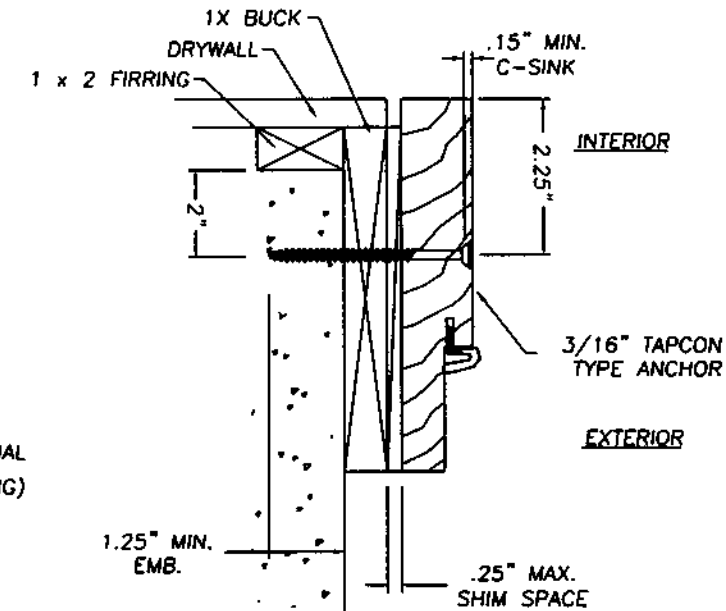

4 VERTICAL SIDE JAMB TO 1X SUB-BUCK

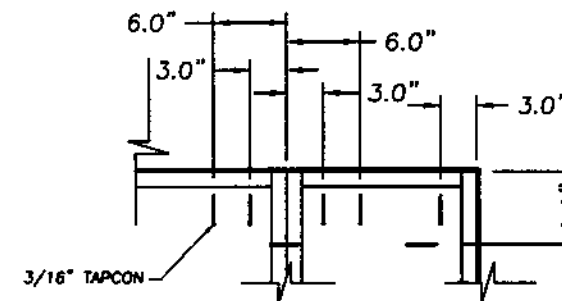

ANCHORING OF SIDELITE THROUGH 1X BUCK

SEPTEMBER 5, 2002

Lyndon F. Schmidt
Florida P. E. No. 43409
19506 French Lace Drive
Lutz, FL 33558

STANLEY

STANLEY DOOR SYSTEMS
7300 REAMES ROAD
CHARLOTTE, NC 28216
PH. (704) 921-3470

ANCHOR CROSS SECTIONS
MASONRY 6'8"
OUT-SWING WOOD FRAME

RW BUILDING
CONSULTANTS, INC.
813.659.9197

DATE: 8/13/02

SCALE: NTS

DWG. BY: WLN

CHK. BY: RW

DRAWING NO.:

ST-101-OC

SHEET 3 OF 4

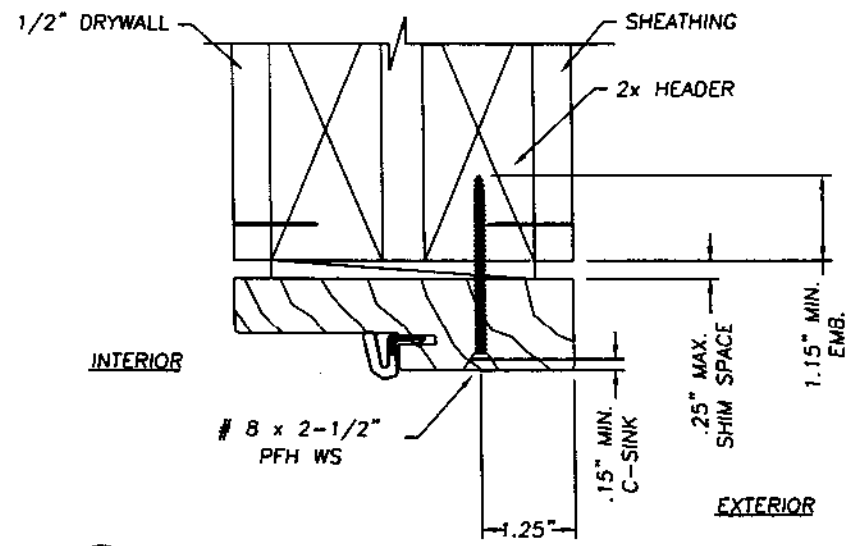

HEAD JAMB

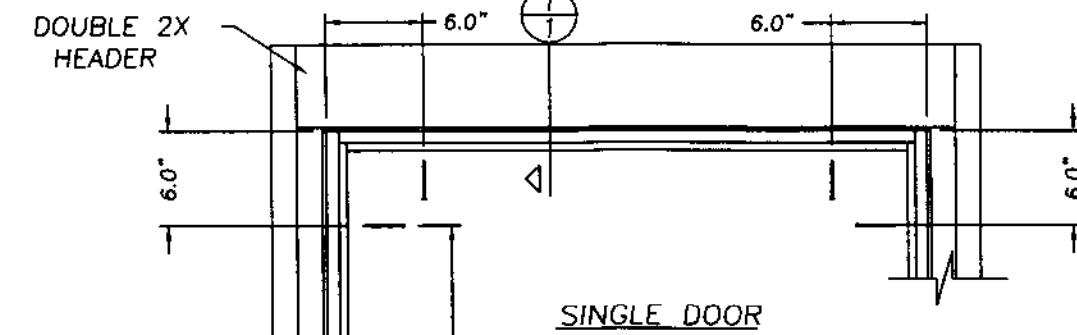

SINGLE DOOR

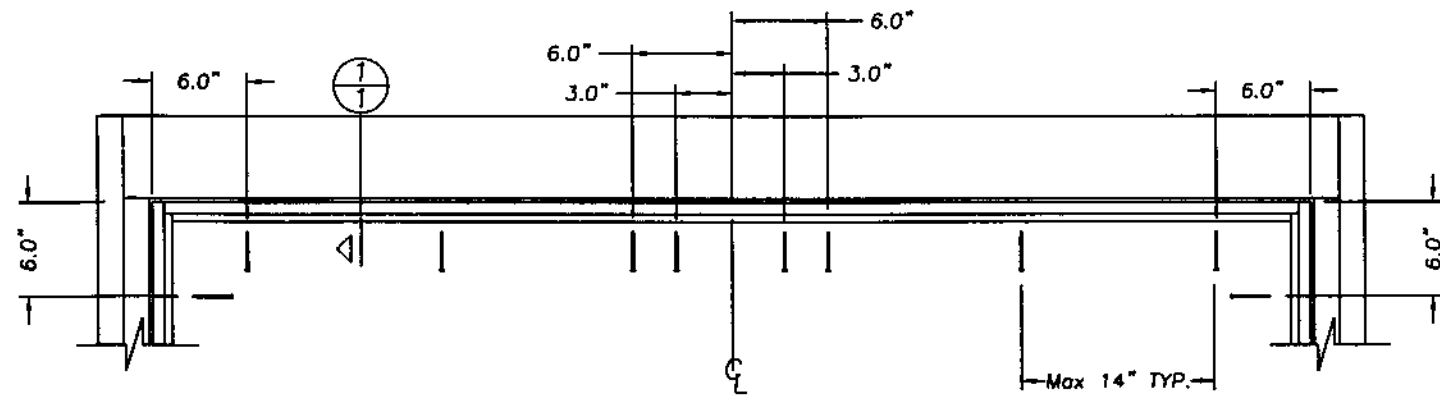
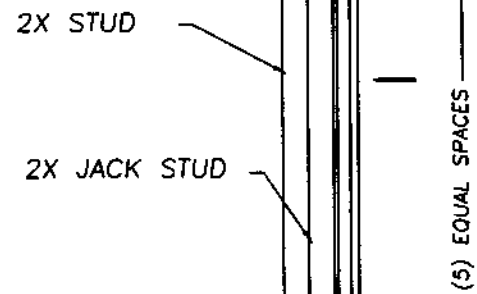

DOUBLE DOOR

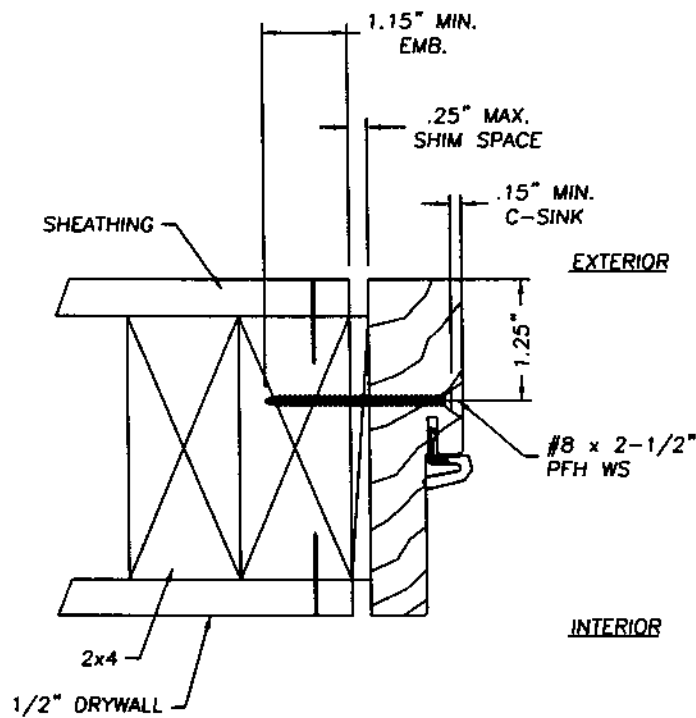

VERTICAL SIDE JAMB

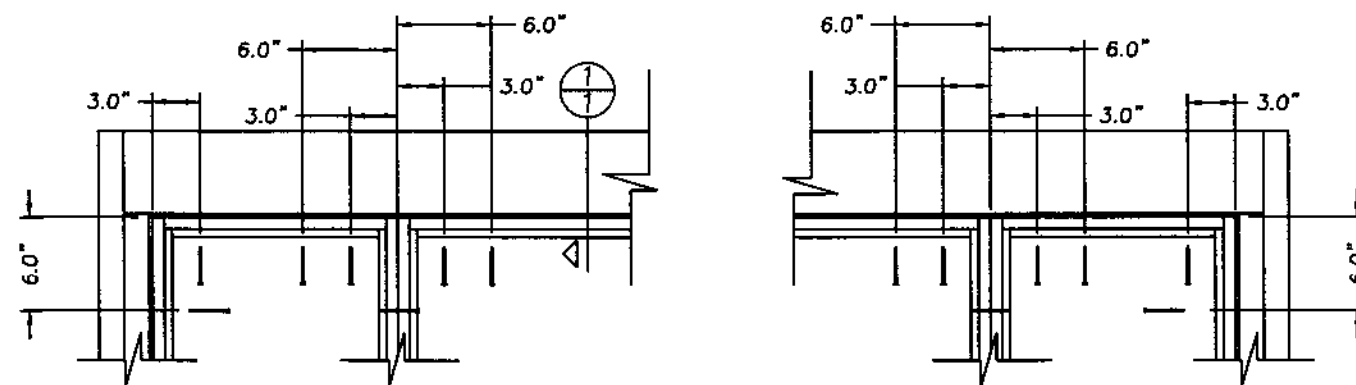

SINGLE OR DOUBLE DOOR WITH SIDELITES

SEPTEMBER 5, 2002

Lyndon F. Schmidt
 Florida P. E. No. 43409
 19506 French Lace Drive
 Lutz, FL 33558

STANLEY

STANLEY DOOR SYSTEMS
 7300 REAMES ROAD
 CHARLOTTE, NC 28216
 PH. (704) 921-3470

ANCHOR CROSS SECTIONS
 WOOD OR STEEL STUD
 IN-SWING / OUT-SWING
 WOOD FRAME

RW BUILDING
 CONSULTANTS, INC.
 813.659.9197

DATE: 8/13/02
 SCALE: NTS
 DWG. BY: WLN
 CHK. BY: RW
 DRAWING NO.:
 ST-101-0C
 SHEET 4 OF 4