

SEARS HOME IMPROVEMENT PRODUCTS

7000 SERIES (AS MFG. BY SIMONTON SERIES 07-07)
EXTRUDED VINYL SLIDING PATIO DOOR

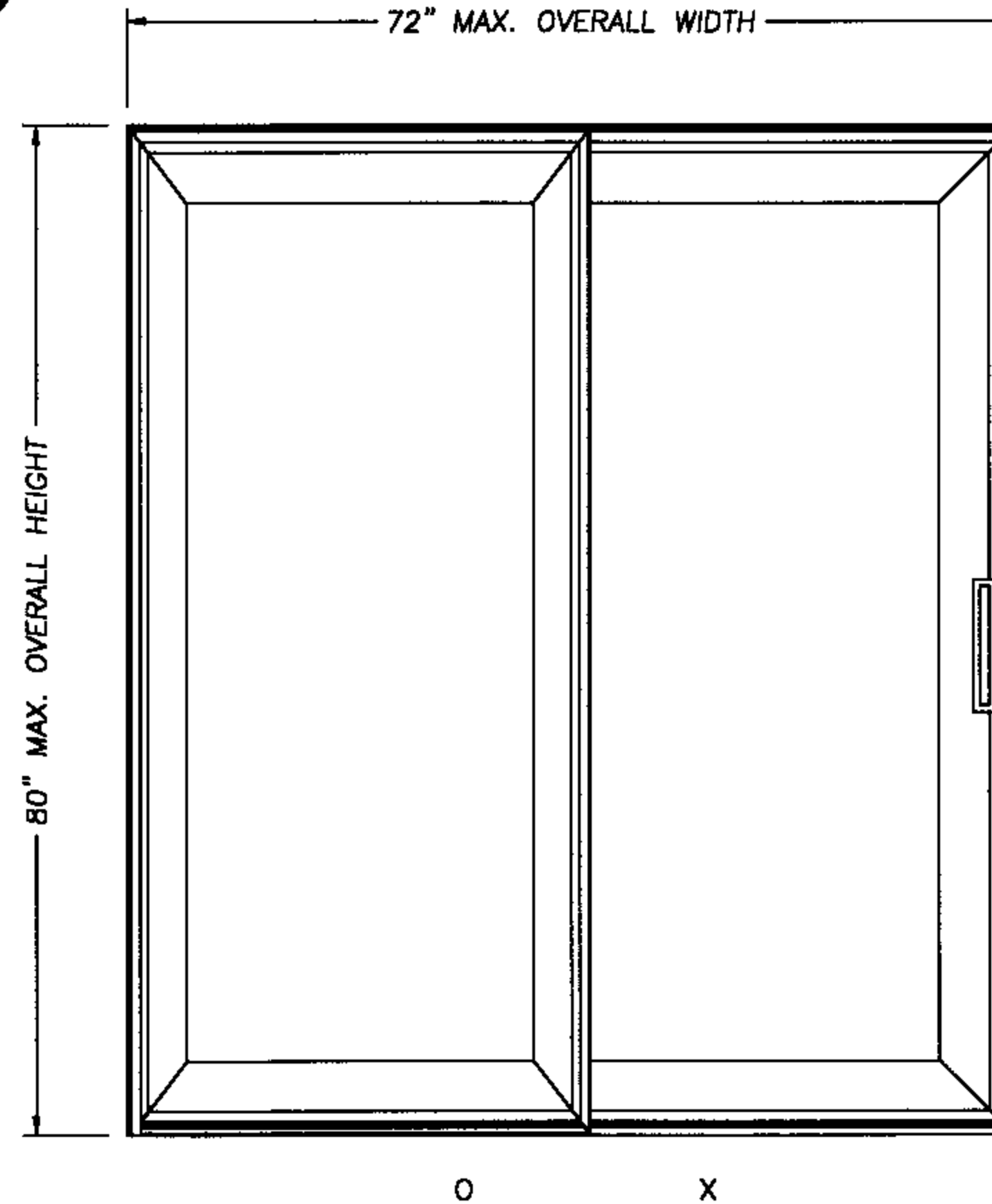

| DESIGN PRESSURE RATING | |
|-------------------------------------|-----------|
| POS. 50.0 | NEG. 50.0 |
| 1" INSULATED GLASS | |
| 1/8" TEMP. - AIR SPACE - 1/8" TEMP. | |

GENERAL NOTES

1. THIS PRODUCT IS DESIGNED TO COMPLY WITH THE FLORIDA BUILDING CODE.
2. PRODUCT ANCHORS SHALL BE AS LISTED AND SPACED AS SHOWN ON DETAILS.
3. WHEN THIS PRODUCT IS USED IN AN AREA REQUIRING WINDBORNE DEBRIS PROTECTION, FLORIDA BUILDING CODE APPROVED IMPACT RESISTANT SHUTTERS ARE REQUIRED.
4. PATIO DOOR ANCHORING TO EXISTING OPENING W/ EXISTING BUCK STRIP TO MASONRY, SEE SHEET 2 OF 2.

PRODUCT DESCRIPTION

1. VINYL PATIO DOOR WITH MITERED AND WELDED CORNERS.
2. THE HEAD AND SIDE JAMBS ARE EXTRUDED VINYL WITH AN EXTERIOR WALL THICKNESS OF 0.070".
3. ALL FRAME PROFILES ALLOW OPTIONAL INSIDE AND OUTSIDE USE OF UV09 SNAP TRIM.
4. ALUMINUM "J" CLIPS AND A CUSTOM DEAD LITE CLIP SECURE THE FIXED PANEL.

Sears Home Improvement Products
1024 Florida Central Parkway
Longwood, FL 32750
PH. 800.222.5030
Fax. 407.332.8216



PRODUCT: SEARS
EXTRUDED VINYL
SLIDING PATIO DOOR
PART OR ASSEMBLY:
GENERAL NOTES &
TYPICAL ELEVATIONS

| NO. | DATE | BY | REVISIONS |
|-----|------|----|-----------|
| | | | |
| | | | |
| | | | |
| | | | |

RW BUILDING
CONSULTANTS, INC.
813.659.9197

Lyndon F. Schmidt
JULY 30, 2002
Lyndon F. Schmidt
Florida P. E. No. 43409
19506 French Lace Drive Lutz, FL 33558

DATE: 6/26/02
SCALE: N.T.S.
DWG. BY: WLN
CHK. BY: RW
DRAWING NO.: SR-106-OC
SHEET 1 OF 2

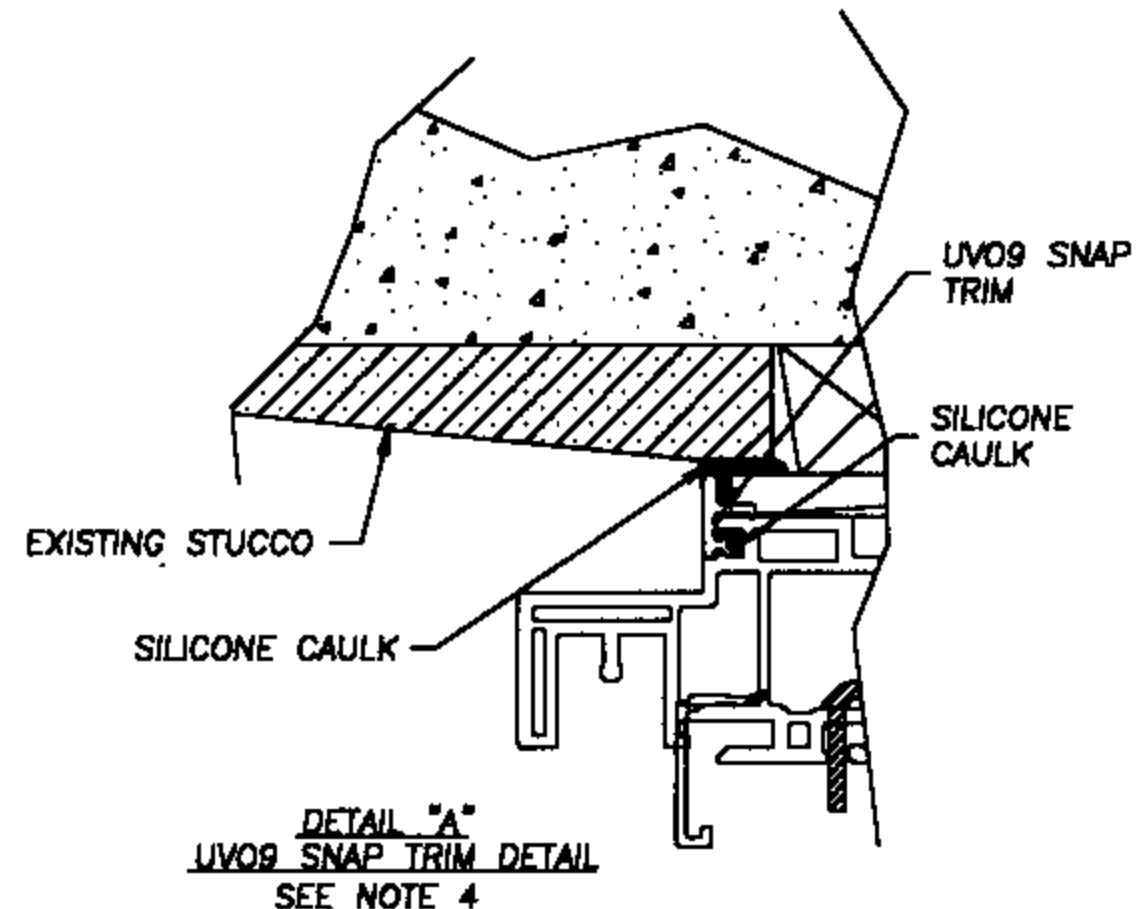
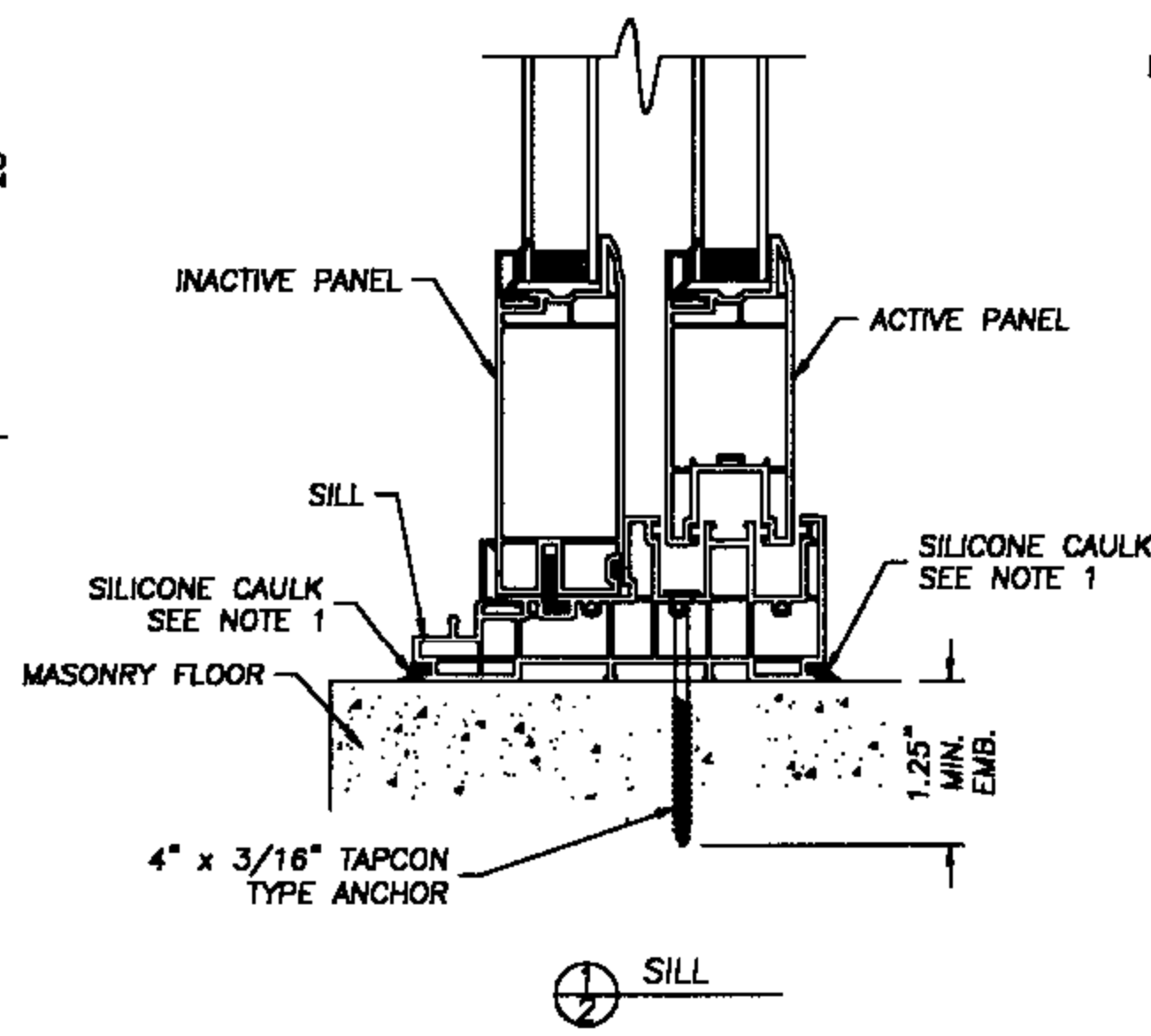
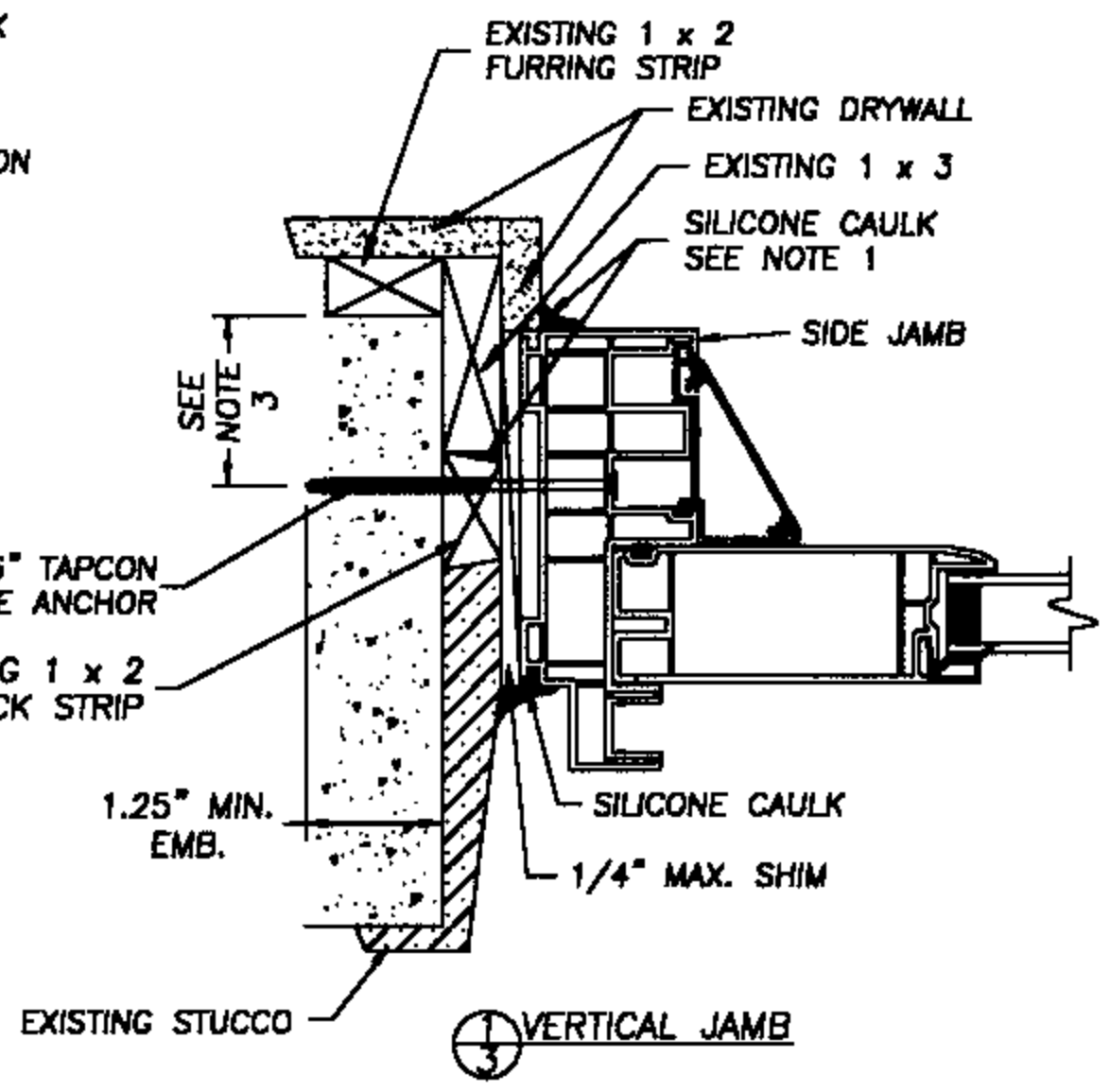
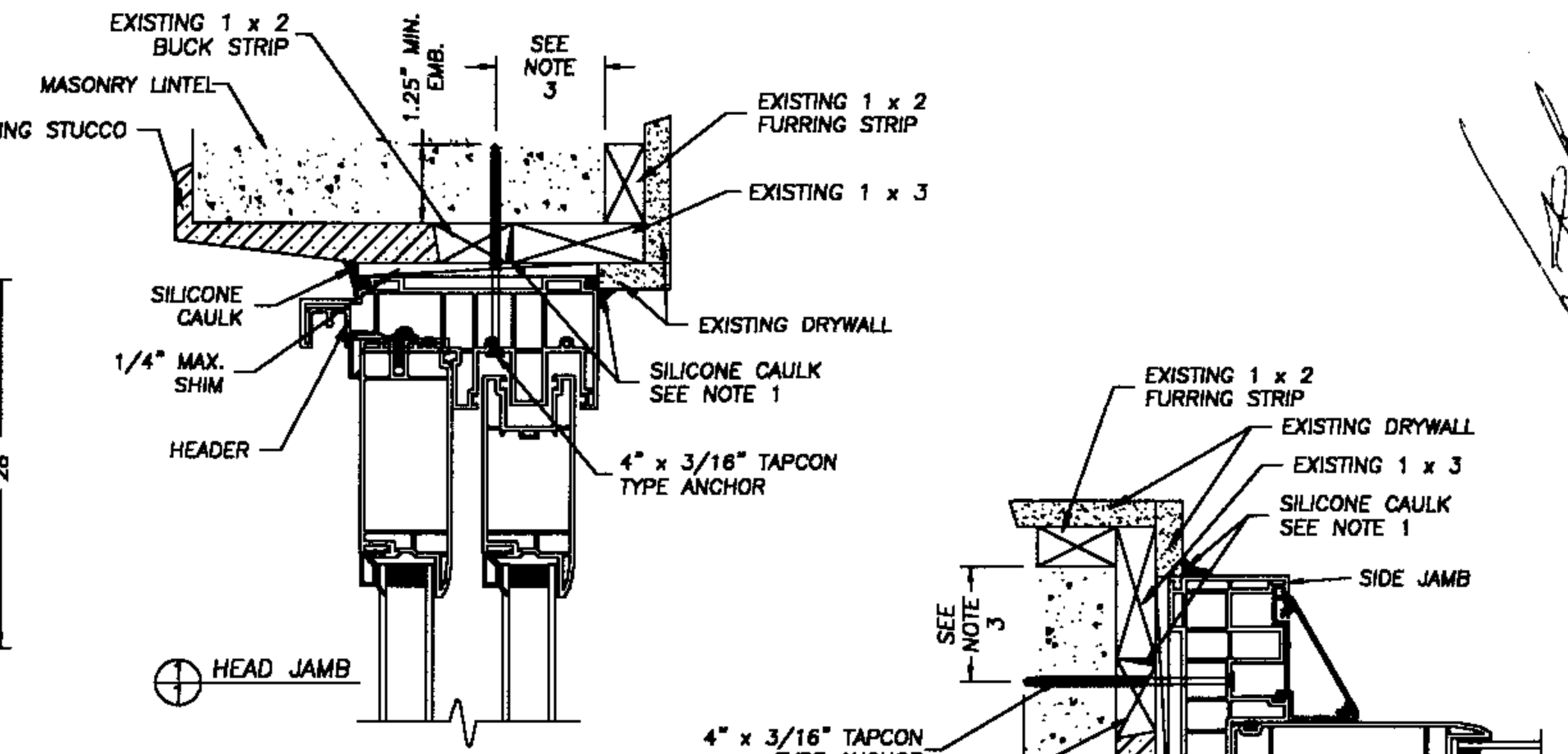
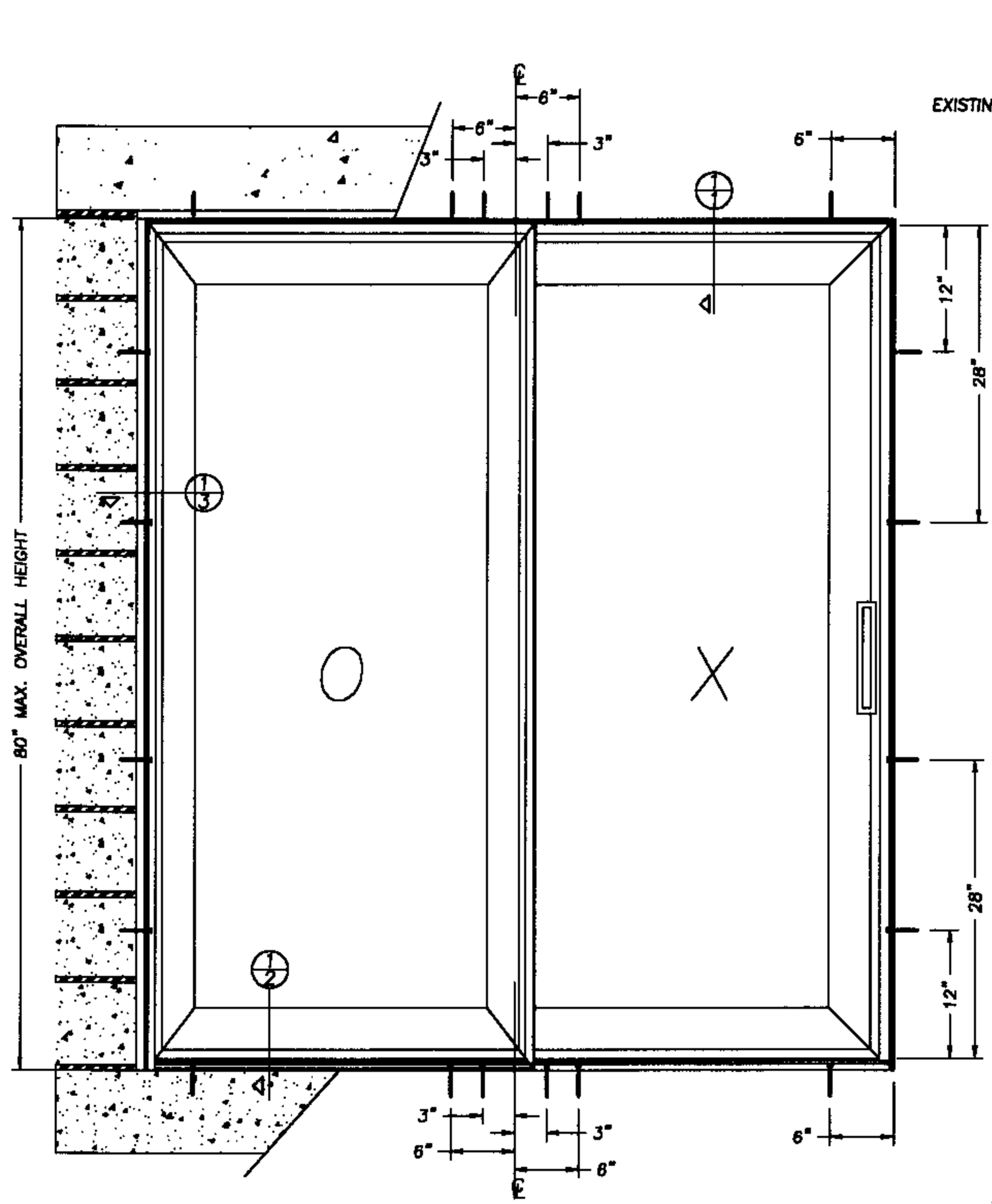

- NOTE:**
1. All interior and exterior perimeter surfaces of the door must be caulked. Caulk between existing 1 x 2 buck strip and existing 1 x 3.
 2. Adjust Tapcon anchor locations, if necessary, to maintain a minimum 2.0" clearance from mortar joints.
 3. A minimum clearance of 2.0" from face of masonry must be maintained.
 4. The UVO9 Snap Trim is used as needed for cosmetic trim only on the head and side jambs. The trim groove on the frame must be filled with silicone before the trim is snapped into place.

JULY 30, 2002
 Lyndon F. Schmidt
 Florida P. E. No. 43409
 19506 French Lace Drive
 Lutz, FL 33558

Sears Home Improvement Products
 1024 Florida Central Parkway
 Longwood, FL 32750
 PH. 800.222.5030
 Fax. 407.332.8216



ANCHORING CROSS SECTIONS
 EXISTING OPENING W/EXISTING
 1X BUCK STRIP TO MASONRY
 VINYL SLIDING PATIO DOOR

RW BUILDING
 CONSULTANTS, INC.
 813.659.9197

DATE: 6/26/02
 SCALE: N.T.S.
 DWG. BY: WLN
 CHK. BY: RW
 DRAWING NO.: SR-106-OC
 SHEET 2 OF 2