

SEARS HOME IMPROVEMENT PRODUCTS

7000 SERIES (AS MFG. BY SIMONTON SERIES 07-70)
EXTRUDED VINYL HORIZONTAL SLIDER WINDOW

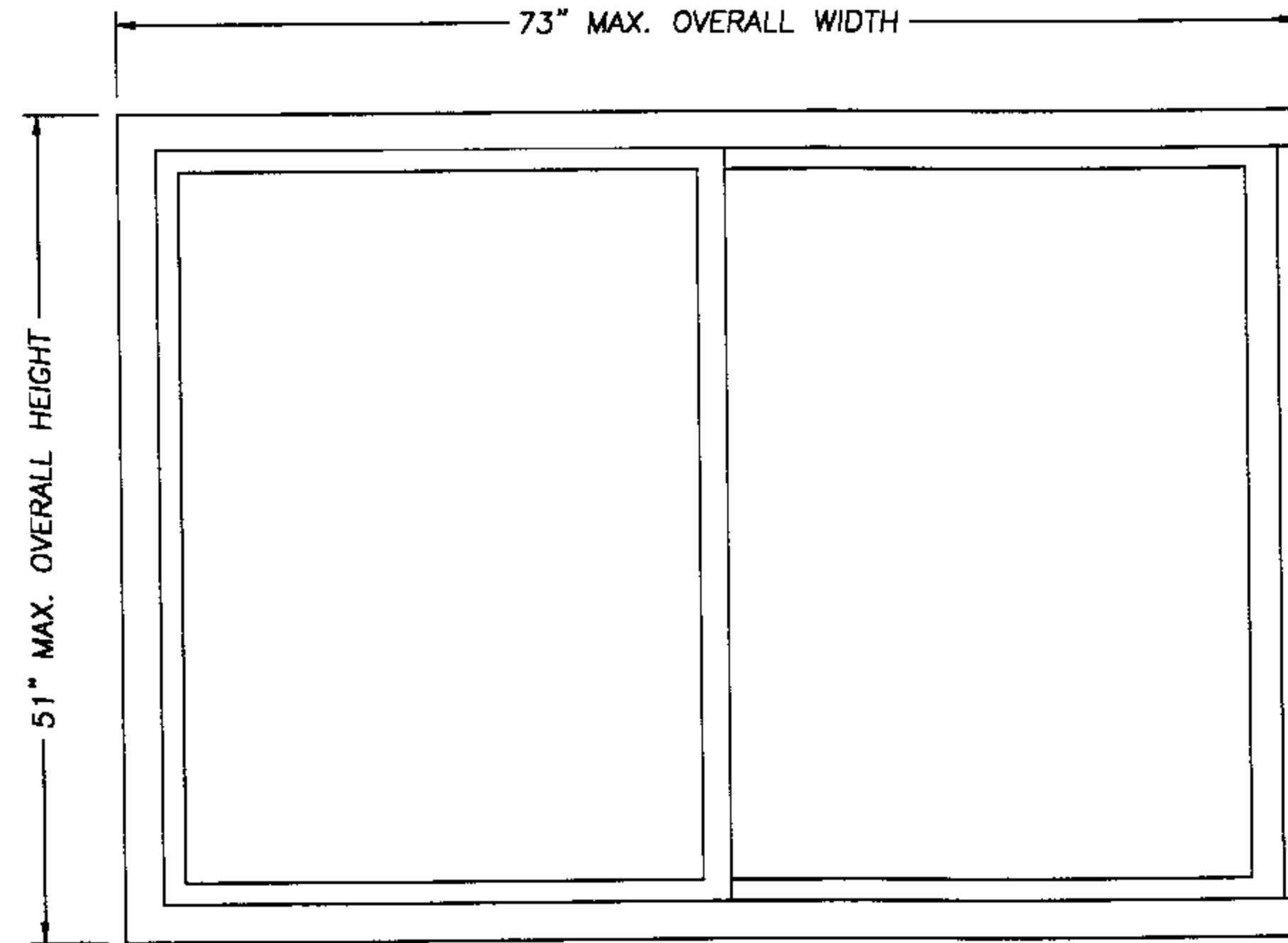

DESIGN PRESSURE RATING	
POS. 50.0	NEG. 50.0
1" OVERALL GLASS THK.	
1/8" ANN. - AIR - 1/8" ANN.	

GENERAL NOTES

1. THIS PRODUCT IS DESIGNED TO COMPLY WITH THE FLORIDA BUILDING CODE.
2. PRODUCT ANCHORS SHALL BE AS LISTED AND SPACED AS SHOWN ON DETAILS.
3. WHEN THIS PRODUCT IS USED IN AN AREA REQUIRING WINDBORNE DEBRIS PROTECTION, FLORIDA BUILDING CODE APPROVED IMPACT RESISTANT SHUTTERS ARE REQUIRED.
4. HORIZONTAL SLIDER ANCHORING TO EXISTING OPENING W/ EXISTING 1X BUCK STRIP TO MASONRY SEE SHEET 2 OF 2.

PRODUCT DESCRIPTION

1. VINYL HORIZONTAL SLIDER WINDOW WITH MITERED AND WELDED CORNERS.
2. THE HEAD AND SIDE JAMBS ARE EXTRUDED VINYL WITH AN EXTERIOR WALL THICKNESS OF 0.070".
3. ALL FRAME PROFILES ALLOW OPTIONAL INSIDE AND OUTSIDE USE OF UV09 SNAP TRIM.
4. THE INTERIOR/EXTERIOR MEETING STILE HAVE RECTANGULAR SHAPED STEEL REINFORCEMENT.

 Lyndon F. Schmidt
 Florida P. E. No. 43409
 19506 French Lace Drive Lutz, FL 33558

Sears Home Improvement Products
 1024 Florida Central Parkway
 Longwood, FL 32750
 PH. 800.222.5030
 Fax. 407.332.8216



PRODUCT: SEARS
 EXTRUDED VINYL
 HORIZONTAL SLIDER WINDOW
 PART OR ASSEMBLY:
 GENERAL NOTES &
 TYPICAL ELEVATIONS

NO.	DATE	BY	REVISIONS

 RW BUILDING
 CONSULTANTS, INC.
 813.659.9197

DATE: 6/24/02
 SCALE: N.T.S.
 DWG. BY: WLN
 CHK. BY: RW
 DRAWING NO.:
 SR-103-OC
 SHEET 1 OF 2

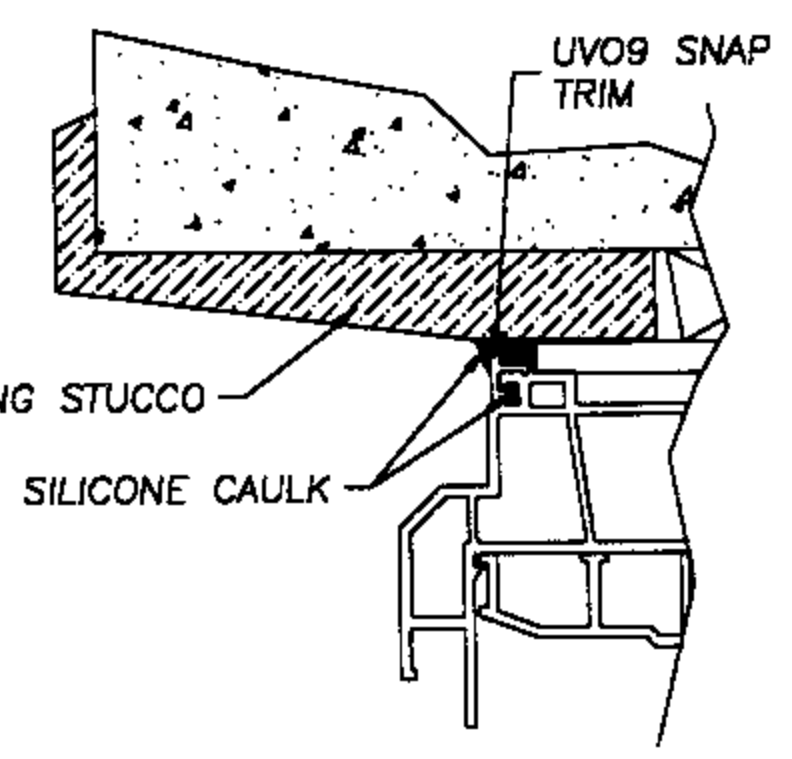
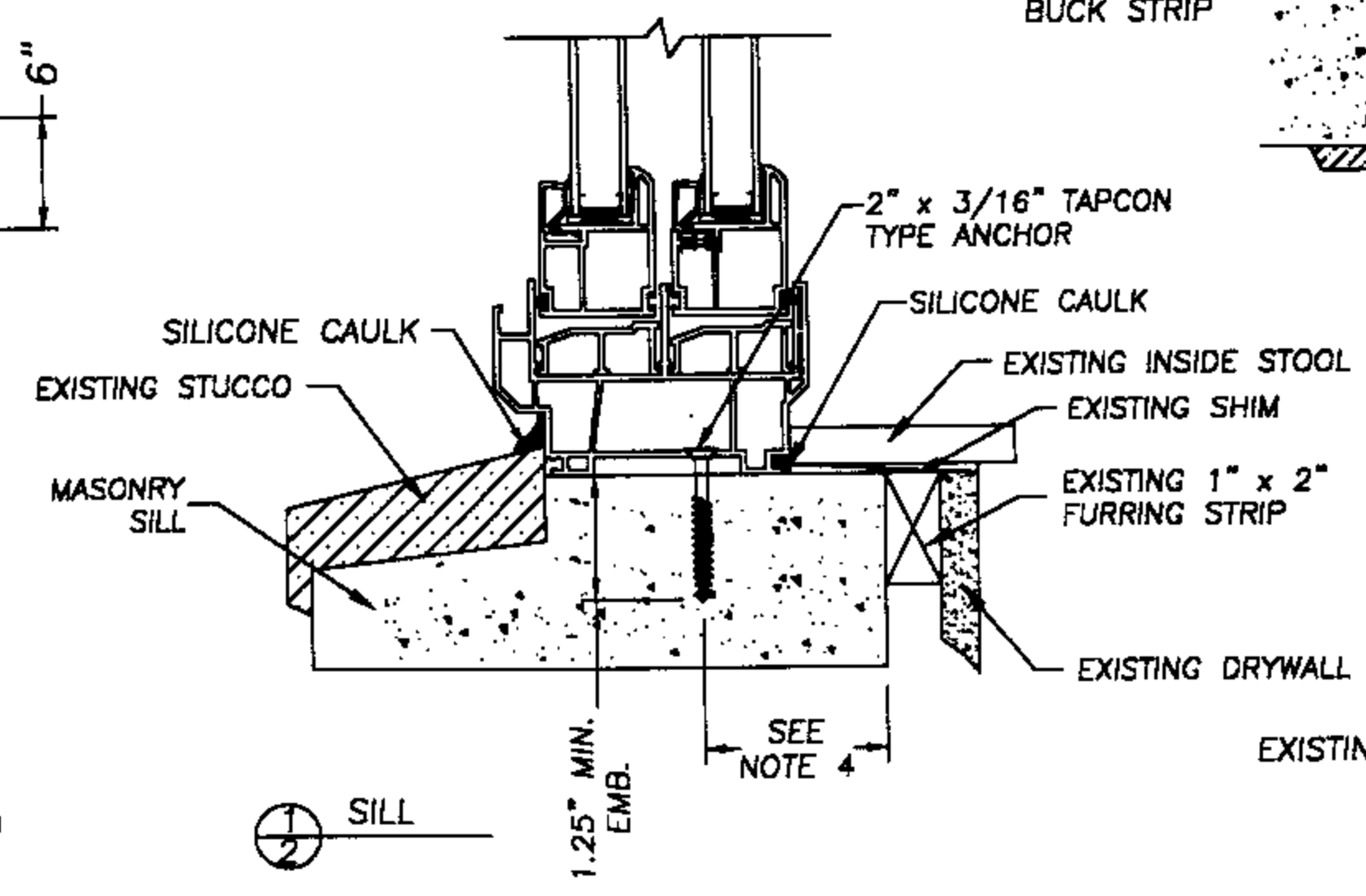
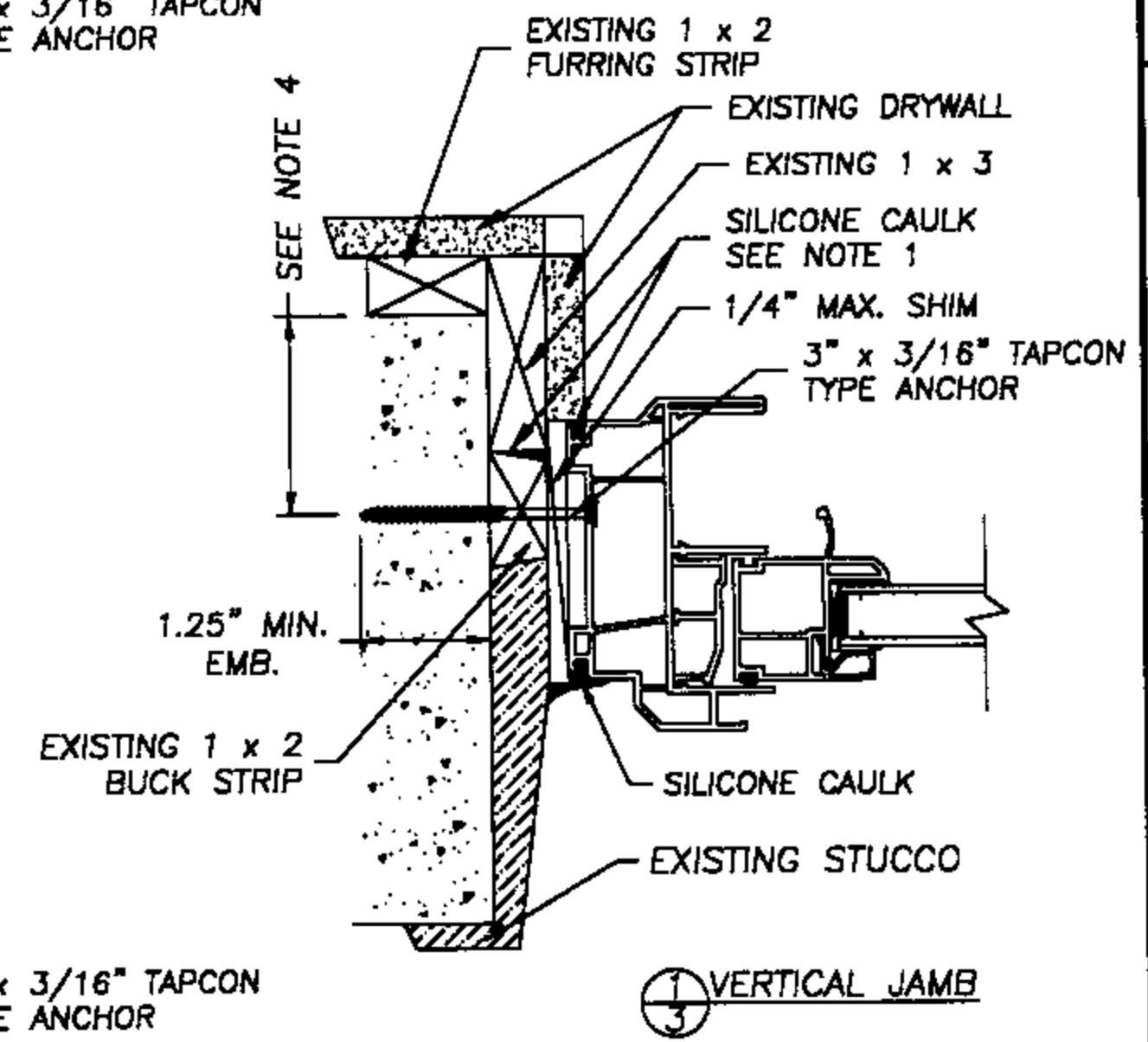
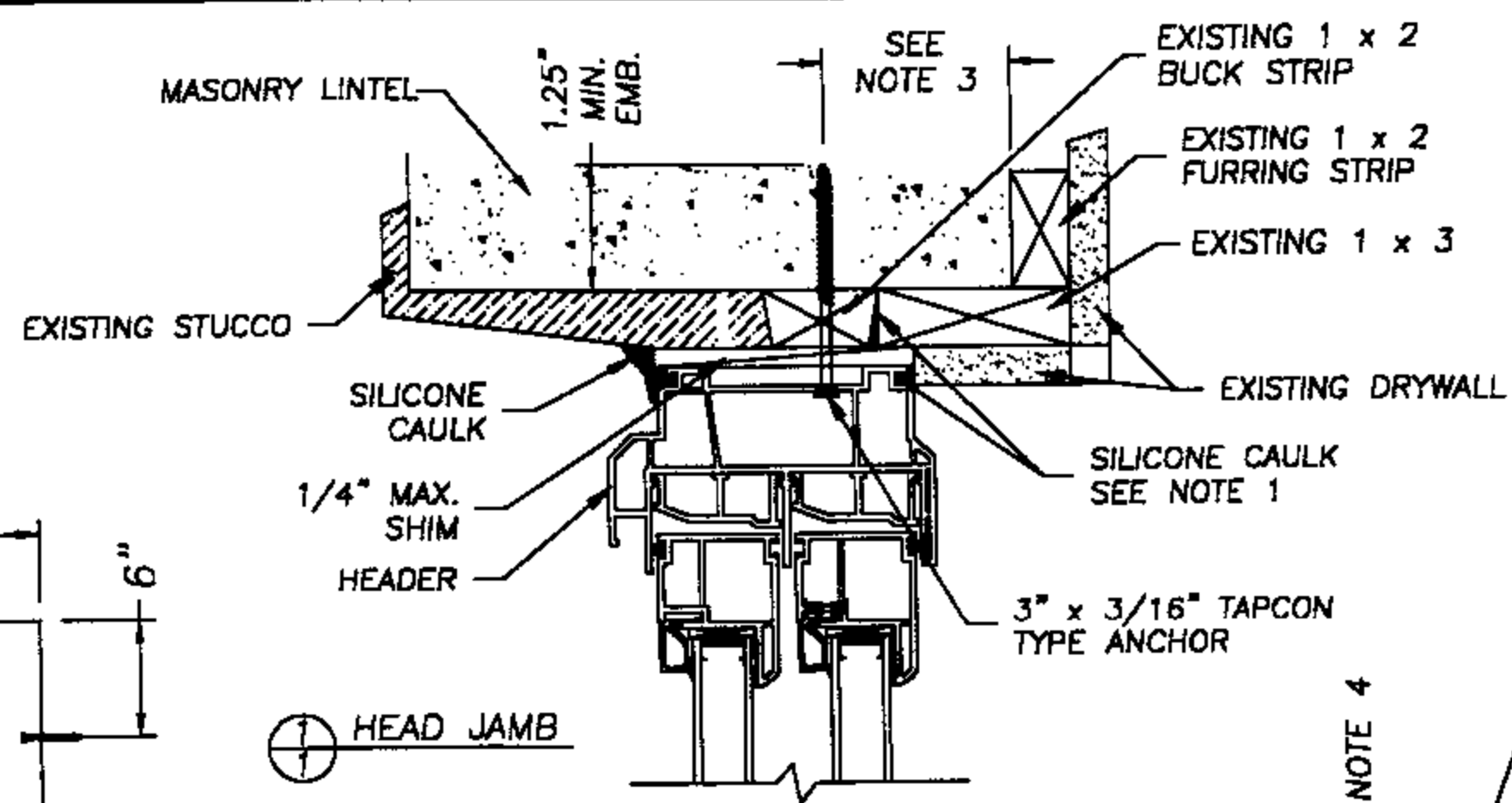
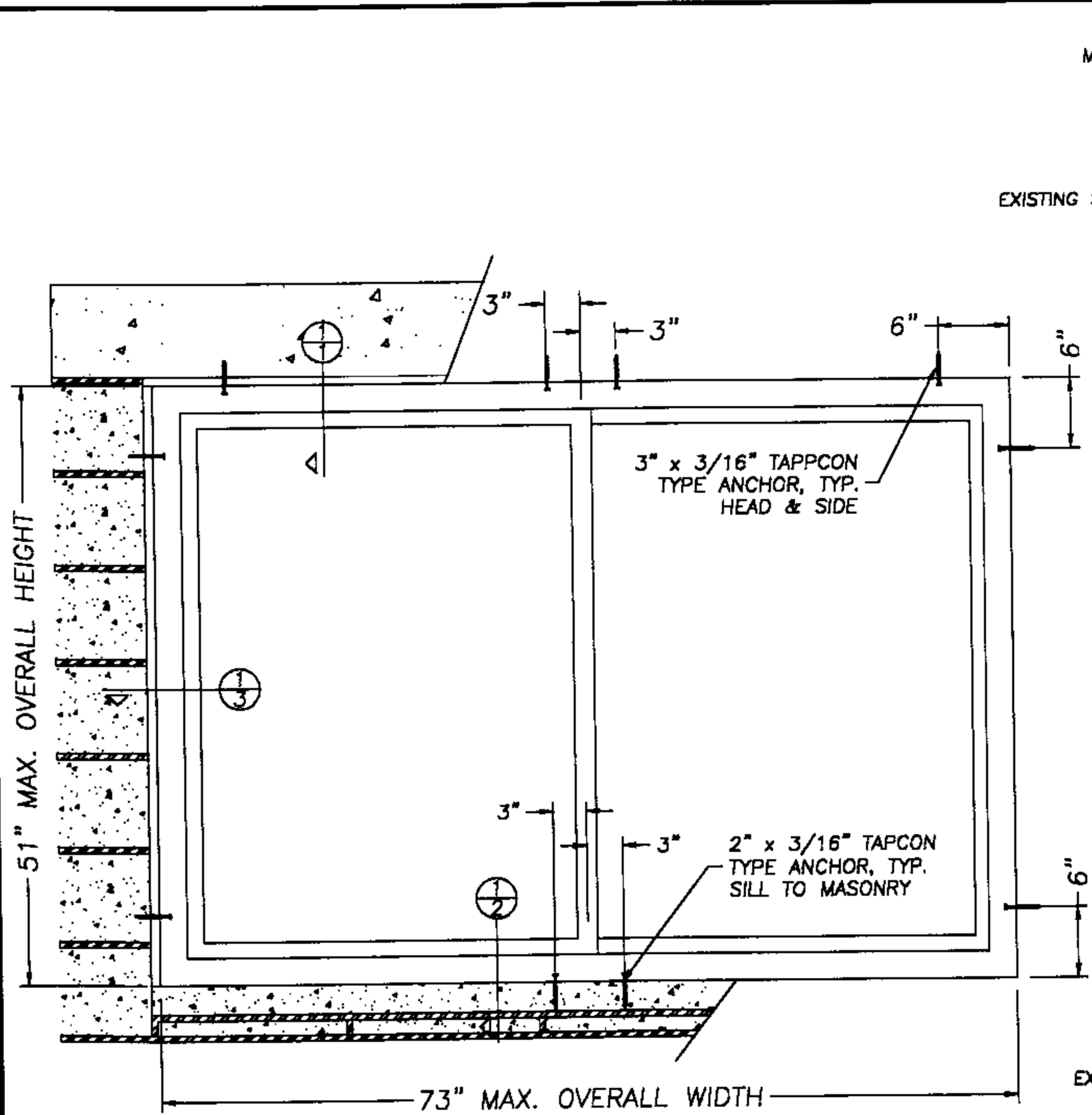

- NOTE:**
1. All interior and exterior perimeter surfaces of the window must be caulked. Caulk between existing 1 x 2 buck strip and existing 1 x 3.
 2. Adjust Tapcon anchor locations, if necessary, to maintain a minimum 2.0" clearance from mortar joints.
 3. A minimum clearance of 2.0" from face of masonry must be maintained.
 4. The UVO9 Snap Trim is used as needed for cosmetic trim only on the head and side jambs. The trim groove on the frame must be filled with silicone before the trim is snapped into place.
 5. All jamb legs must be supported by a 1X buck. Cut the new 1X buck with sufficient width to support jamb legs not supported by the existing 1X buck.

DETAIL "A"
UVO9 SNAP TRIM DETAIL
SEE NOTE 5

July 29, 2002
Lyndon F. Schmidt
Florida P. E. No. 43409
19506 French Lace Drive
Lutz, FL 33558

Sears Home Improvement Products
1024 Florida Central Parkway
Langwood, FL 32750
PH. 800.222.5030
Fax. 407.332.8216

ANCHORING CROSS SECTIONS
EXISTING OPENING W/EXISTING
1X BUCK STRIP TO MASONRY
VINYL HORIZONTAL SLIDER

RW BUILDING
CONSULTANTS, INC.
813.659.9197

DATE: 6/24/02
SCALE: N.T.S.
DWG. BY: WLN
CHK. BY: RW
DRAWING NO.: SR-103-OC
SHEET 2 OF 2