

P. O. Box 1119 • Jasper, Florida 32052

SINGLE HUNG INSTALLATIONROUGH OPENING

1. Check to be sure the opening is proper size.
2. Sill plate must be level.
3. Provide $\frac{1}{4}$ to $\frac{1}{2}$ inch of clearance on both height and width.
4. In wood frame installations. Cover the outside face of the opening with strips of asphalted building paper or other material as specified by local building code. Overlap sides over bottom strip. **Top strip is applied over nailing fin after window is installed.**

UNIT

1. Open and operate sash and check that the unit operates properly before installing.
2. Close and lock sash.

INSTALLATION PROCEDURE

- 1a. In wood frame construction, apply a continuous bead of sealant (bedding joint) around the full perimeter of the backside of the mounting fin. Apply the sealant in line with any pre-punched holes on the mounting fin.
- 1b. In masonry construction, sealant may be applied around the entire buck at the point where the backside (interior surface) of the mounting flange will make contact with the seal.
2. Center unit in opening.
3. Select and apply shims
4. Adjust the shims and check the window for level, plumb, and true. Make sure the window is not bowed in or out. Distance between jambs at Meeting Rail should measure the same as Head and Sill.
- 5a. For wood frame installations fasten the upper corner in place through the nail fin. Do not drive the fastener all the way in.
- 5b. For concrete/masonry wall installations fasten the upper corner in place through the balance channel. Do not drive the fastener all the way in.
6. Make sure the window is square, operates smoothly, and operable sash are sitting square in their openings.
7. Fasten the corner diagonally opposite the upper corner that was fastened first.
8. Continue to fasten sides, top, and bottom through the mounting fin; rechecking the unit to ensure it is set plumb, level, square, and true. Fastener heads should not compress the nail fin when put in place.
9. If applying additional insulation behind jambs and under sill be careful not to bow frame in.
10. In wood frame installations the top flashing strip is applied over nailing fin after window is installed at this time.

Sheet of Books
6/17/02

ESP Energy Saving Products of Florida, Inc.

Our Name Says It All!

P. O. Box 1119 • Jasper, Florida 32052

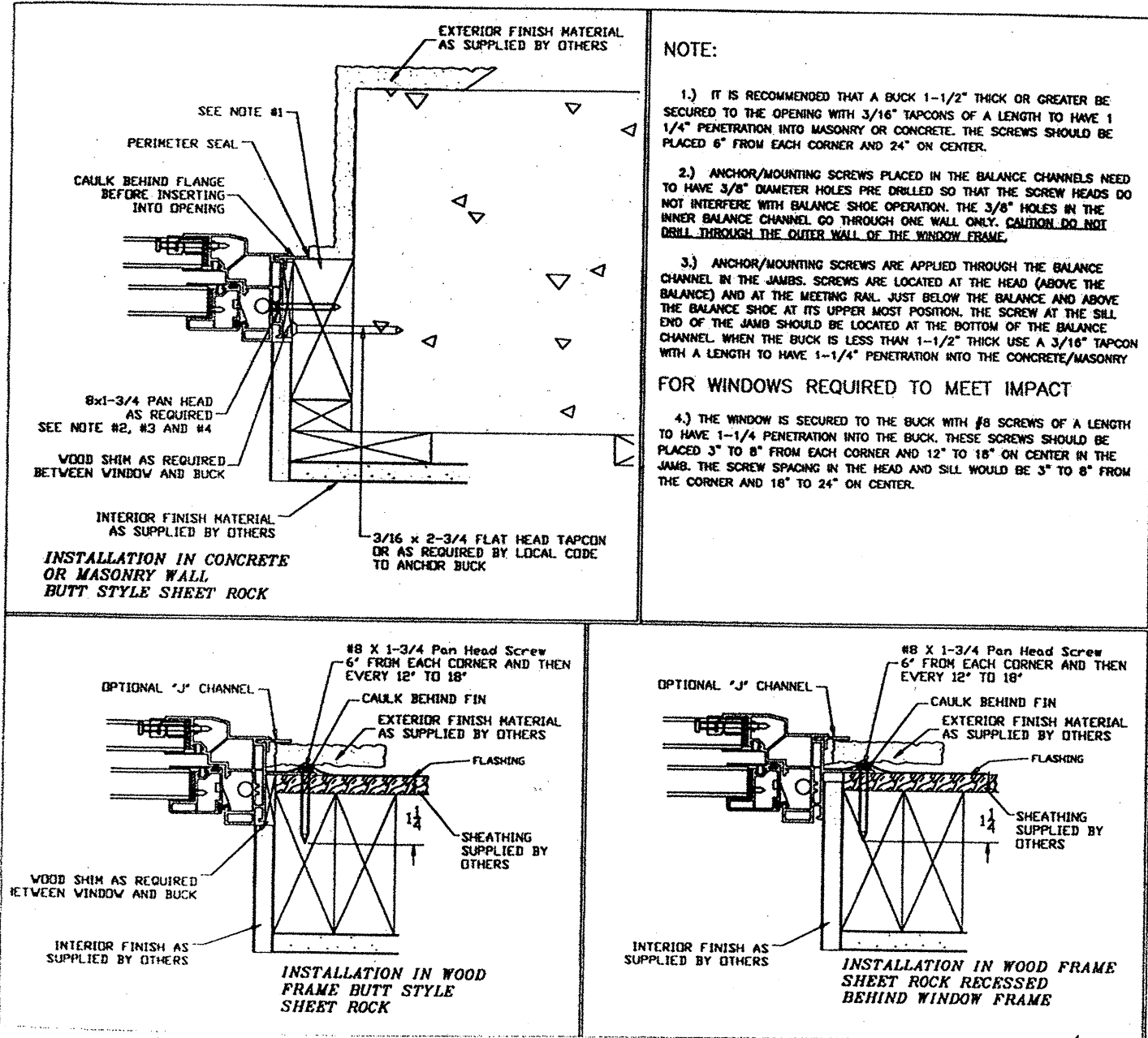

Robert J. Bradley
6/17/02

P. O. Box 1119 • Jasper, Florida 32052

SINGLE HUNG INSTALLATION

ROUGH OPENING

1. Check to be sure the opening is proper size.
2. Sill plate must be level.
3. Provide $\frac{1}{4}$ to $\frac{1}{2}$ inch of clearance on both height and width.
4. In wood frame installations. Cover the outside face of the opening with strips of asphalted building paper or other material as specified by local building code. Overlap sides over bottom strip. **Top strip is applied over nailing fin after window is installed.**

UNIT

1. Open and operate sash and check that the unit operates properly before installing.
2. Close and lock sash.

INSTALLATION PROCEDURE

- 1a. In wood frame construction, apply a continuous bead of sealant (bedding joint) around the full perimeter of the backside of the mounting fin. Apply the sealant in line with any pre-punched holes on the mounting fin.
- 1b. In masonry construction, sealant may be applied around the entire buck at the point where the backside (interior surface) of the mounting flange will make contact with the seal.
2. Center unit in opening.
3. Select and apply shims
4. Adjust the shims and check the window for level, plumb, and true. Make sure the window is not bowed in or out. Distance between jambs at Meeting Rail should measure the same as Head and Sill.
- 5a. For wood frame installations fasten the upper corner in place through the nail fin. Do not drive the fastener all the way in.
- 5b. For concrete/masonry wall installations fasten the upper corner in place through the balance channel. Do not drive the fastener all the way in.
6. Make sure the window is square, operates smoothly, and operable sash are sitting square in their openings.
7. Fasten the corner diagonally opposite the upper corner that was fastened first.
8. Continue to fasten sides, top, and bottom through the mounting fin; rechecking the unit to ensure it is set plumb, level, square, and true. Fastener heads should not compress the nail fin when put in place.
9. If applying additional insulation behind jambs and under sill be careful not to bow frame in.
10. In wood frame installations the top flashing strip is applied over nailing fin after window is installed at this time.

Shelley B. Adams
6/17/02

**E
S
P**

Energy Saving Products of Florida, Inc.

Our Name Says It All!

P. O. Box 1119 • Jasper, Florida 32052

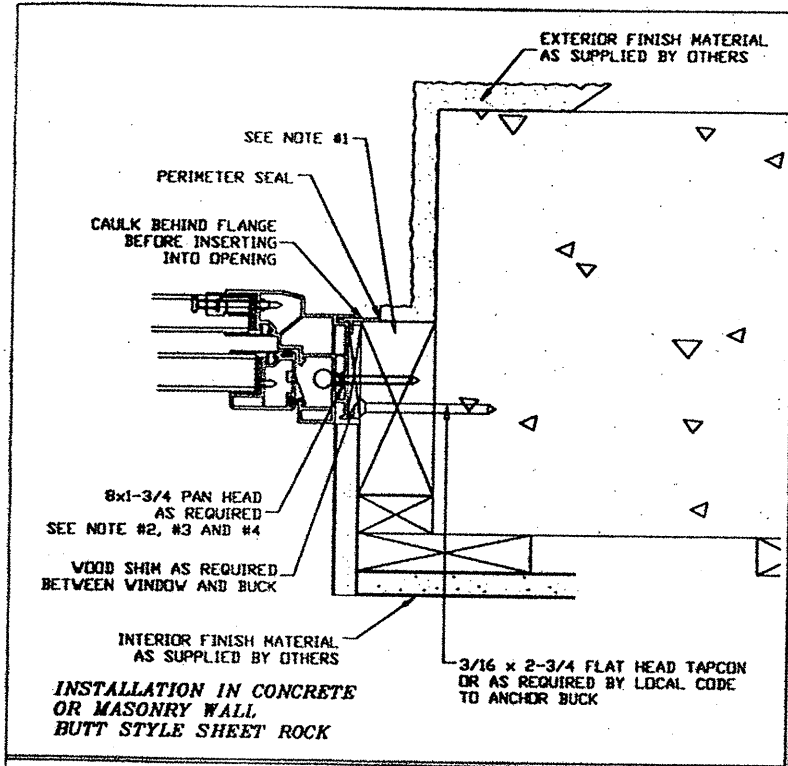

NOTE:

1.) IT IS RECOMMENDED THAT A BUCK 1-1/2" THICK OR GREATER BE SECURED TO THE OPENING WITH 3/16" TAPCONS OF A LENGTH TO HAVE 1 1/4" PENETRATION INTO MASONRY OR CONCRETE. THE SCREWS SHOULD BE PLACED 6" FROM EACH CORNER AND 24" ON CENTER.

2.) ANCHOR/MOUNTING SCREWS PLACED IN THE BALANCE CHANNELS NEED TO HAVE 3/8" DIAMETER HOLES PRE DRILLED SO THAT THE SCREW HEADS DO NOT INTERFERE WITH BALANCE SHOE OPERATION. THE 3/8" HOLES IN THE INNER BALANCE CHANNEL GO THROUGH ONE WALL ONLY. CAUTION DO NOT DRILL THROUGH THE OUTER WALL OF THE WINDOW FRAME.

3.) ANCHOR/MOUNTING SCREWS ARE APPLIED THROUGH THE BALANCE CHANNEL IN THE JAMBS. SCREWS ARE LOCATED AT THE HEAD (ABOVE THE BALANCE) AND AT THE MEETING RAIL JUST BELOW THE BALANCE AND ABOVE THE BALANCE SHOE AT ITS UPPER MOST POSITION. THE SCREW AT THE SILL END OF THE JAMB SHOULD BE LOCATED AT THE BOTTOM OF THE BALANCE CHANNEL WHEN THE BUCK IS LESS THAN 1-1/2" THICK USE A 3/16" TAPCON WITH A LENGTH TO HAVE 1-1/4" PENETRATION INTO THE CONCRETE/MASONRY

FOR WINDOWS REQUIRED TO MEET IMPACT

4.) THE WINDOW IS SECURED TO THE BUCK WITH #8 SCREWS OF A LENGTH TO HAVE 1-1/4" PENETRATION INTO THE BUCK. THESE SCREWS SHOULD BE PLACED 3" TO 8" FROM EACH CORNER AND 12" TO 18" ON CENTER IN THE JAMB. THE SCREW SPACING IN THE HEAD AND SILL WOULD BE 3" TO 8" FROM THE CORNER AND 16" TO 24" ON CENTER.

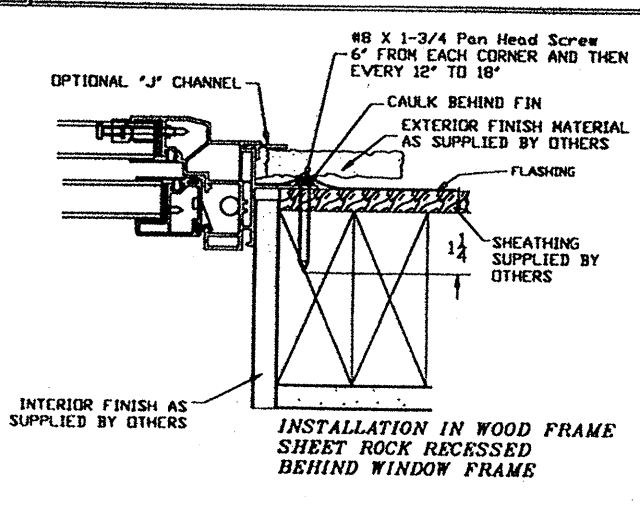
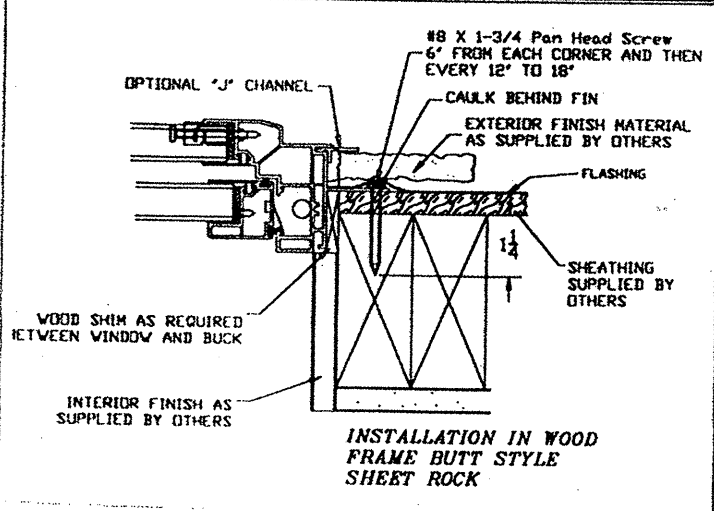

Robert J. [Signature]
6/17/02