

American Craftsman

SERIES 2900
EXTRUDED VINYL SINGLE HUNG WINDOWS
(Mfg. By Silverline Building Products)

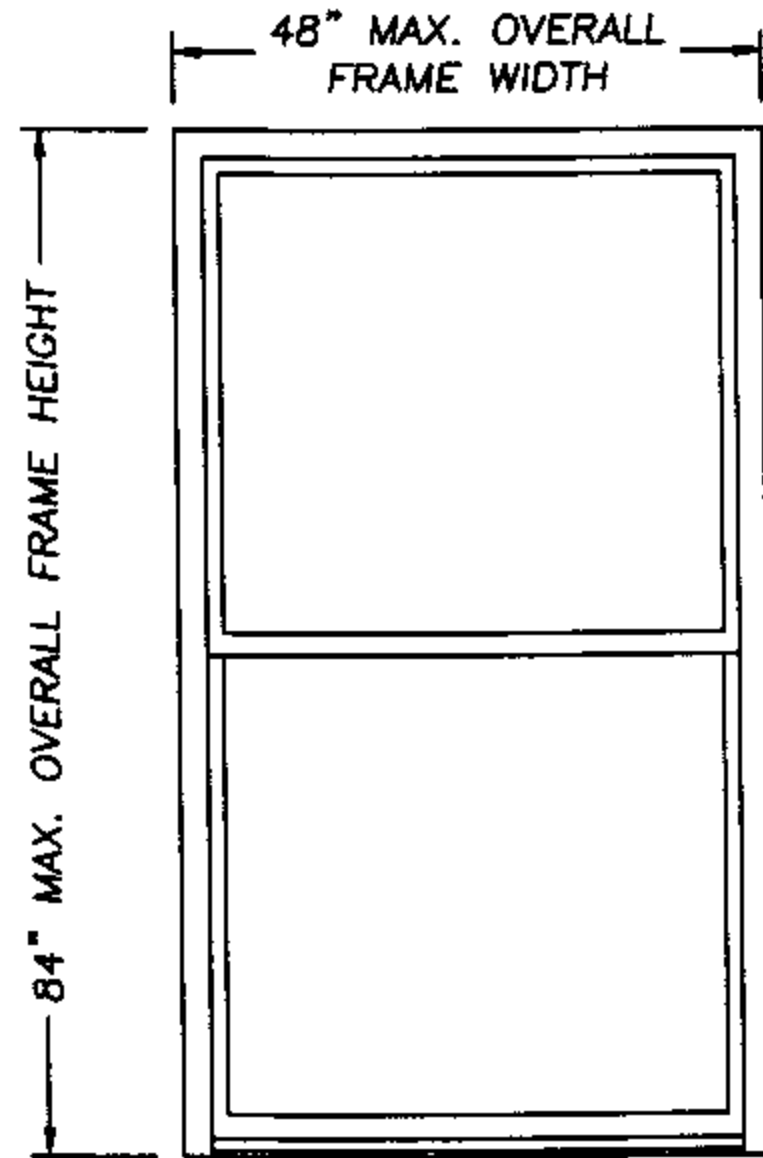

O
X

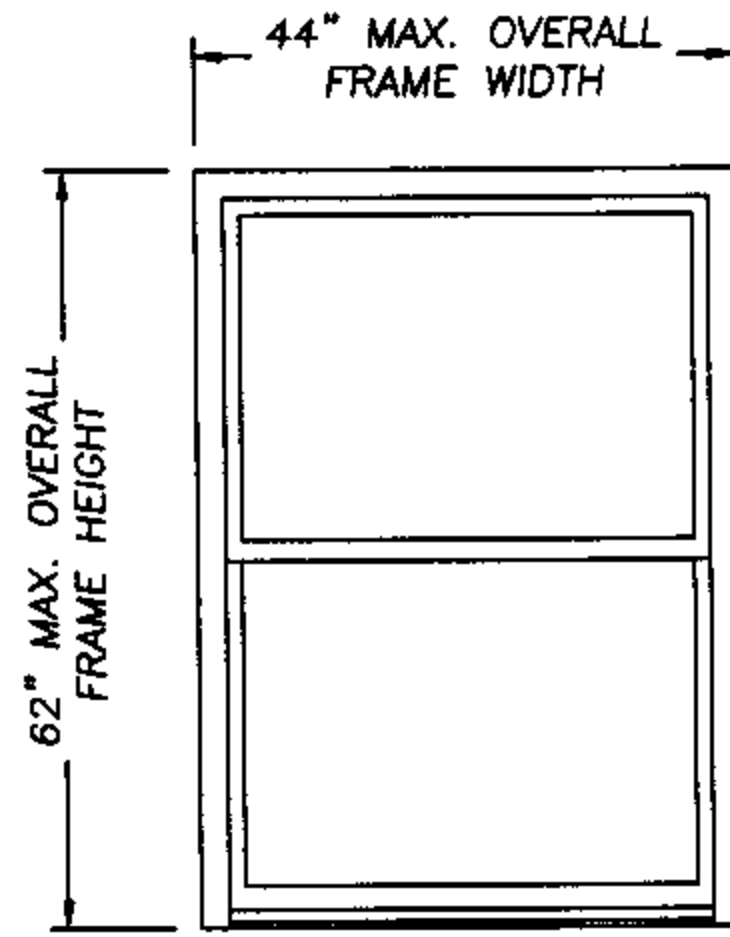

O
X

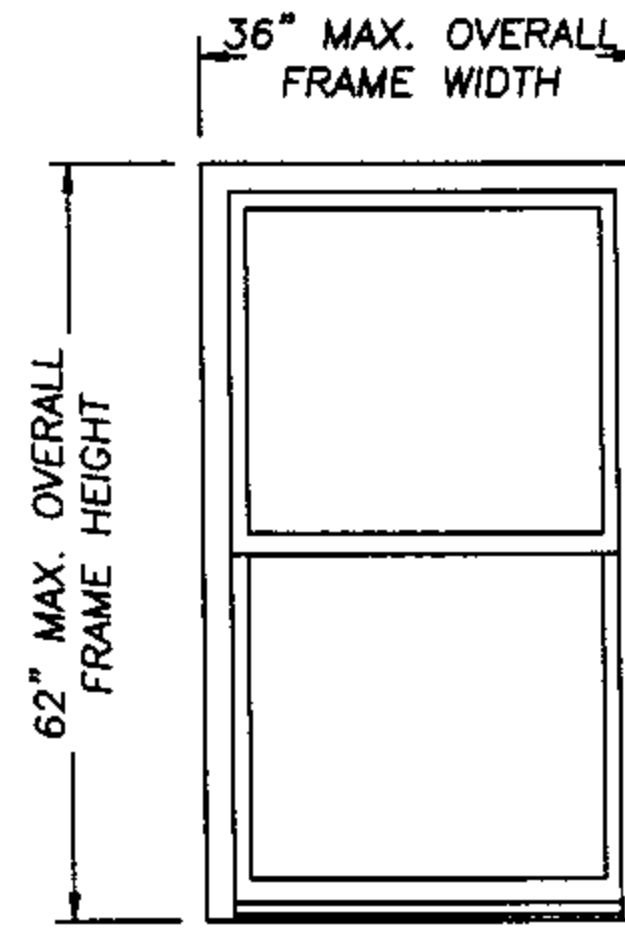

O
X

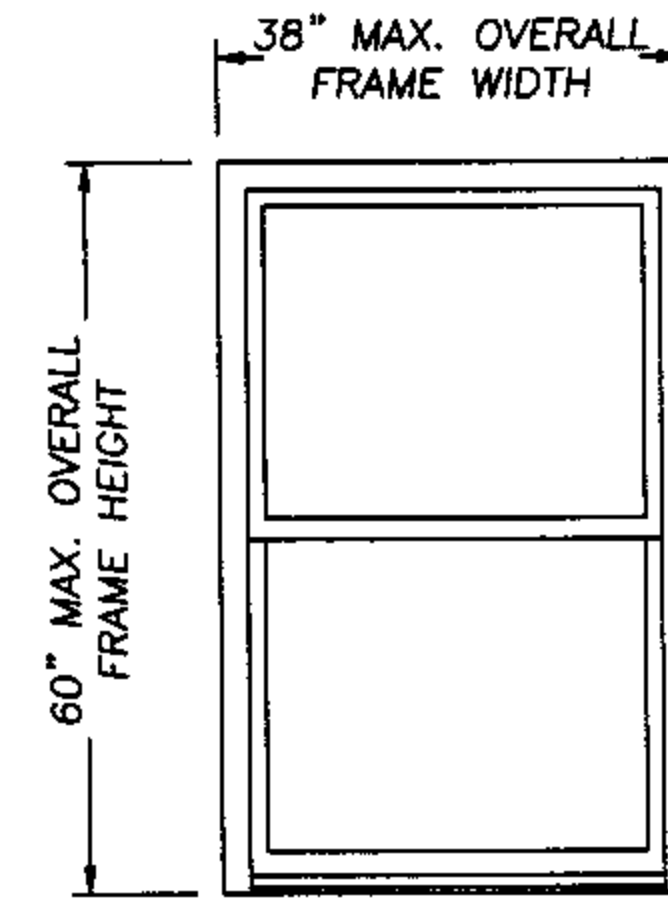

O
X

DESIGN PRESSURE RATING
POS. 30.0 NEG. 30.0

GLASS TABLE
5/8" INSULATED GLASS
1/8" ANN. - AIR SPACE - 1/8" ANN.

DESIGN PRESSURE RATING
POS. 45.0 NEG. 45.0

GLASS TABLE
5/8" INSULATED GLASS
1/8" ANN. - AIR SPACE - 1/8" ANN.

DESIGN PRESSURE RATING
POS. 50.0 NEG. 50.0

GLASS TABLE
5/8" INSULATED GLASS
1/8" ANN. - AIR SPACE - 1/8" ANN.

DESIGN PRESSURE RATING
POS. 50.0 NEG. 50.0

GLASS TABLE
5/8" INSULATED GLASS
1/8" ANN. - AIR SPACE - 1/8" ANN.

GENERAL NOTES

1. THIS PRODUCT IS DESIGNED TO COMPLY WITH THE FLORIDA BUILDING CODE.
2. PRODUCT ANCHORS SHALL BE AS LISTED AND SPACED AS SHOWN ON DETAILS.
3. WHEN THIS PRODUCT IS USED IN AN AREA REQUIRING WINDBORNE DEBRIS PROTECTION, FLORIDA BUILDING CODE APPROVED IMPACT RESISTANT SHUTTERS ARE REQUIRED.
4. MASONRY ANCHORING FOR 1x BUCK SEE SHEET 2 OF 3.
5. MASONRY ANCHORING FOR 2x BUCK SEE SHEET 3 OF 3.

PRODUCT DESCRIPTION

1. VINYL SINGLE HUNG WINDOW WITH MITERED AND WELDED CORNERS.
2. THE HEAD AND SIDE JAMBS ARE EXTRUDED VINYL WITH AN EXTERIOR WALL THICKNESS OF 0.070" +/- 0.008".
3. BOTH MEETING RAIL AND FIXED RAIL ARE REINFORCED WITH STEEL "U" CHANNEL.

Lyndon F. Schmidt
JULY 23, 2002

Lyndon F. Schmidt
Florida P. E. No. 43409
19506 French Lace Drive Lutz, FL 33558

American Craftsman Windows
P. O. Box 6029
North Brunswick, NJ 08902
PH. 800 299-9501

PRODUCT: AMERICAN CRAFTSMAN
EXTRUDED VINYL
SINGLE HUNG WINDOW
PART OR ASSEMBLY:
GENERAL NOTES &
TYPICAL ELEVATIONS

NO.	DATE	BY	REVISIONS

RW BUILDING
CONSULTANTS, INC.
813.659.9197

DATE: 6/13/02
SCALE: N.T.S.
DWG. BY: WLN
CHK. BY: RW
DRAWING NO.:
AC-404-OC
SHEET 1 OF 3

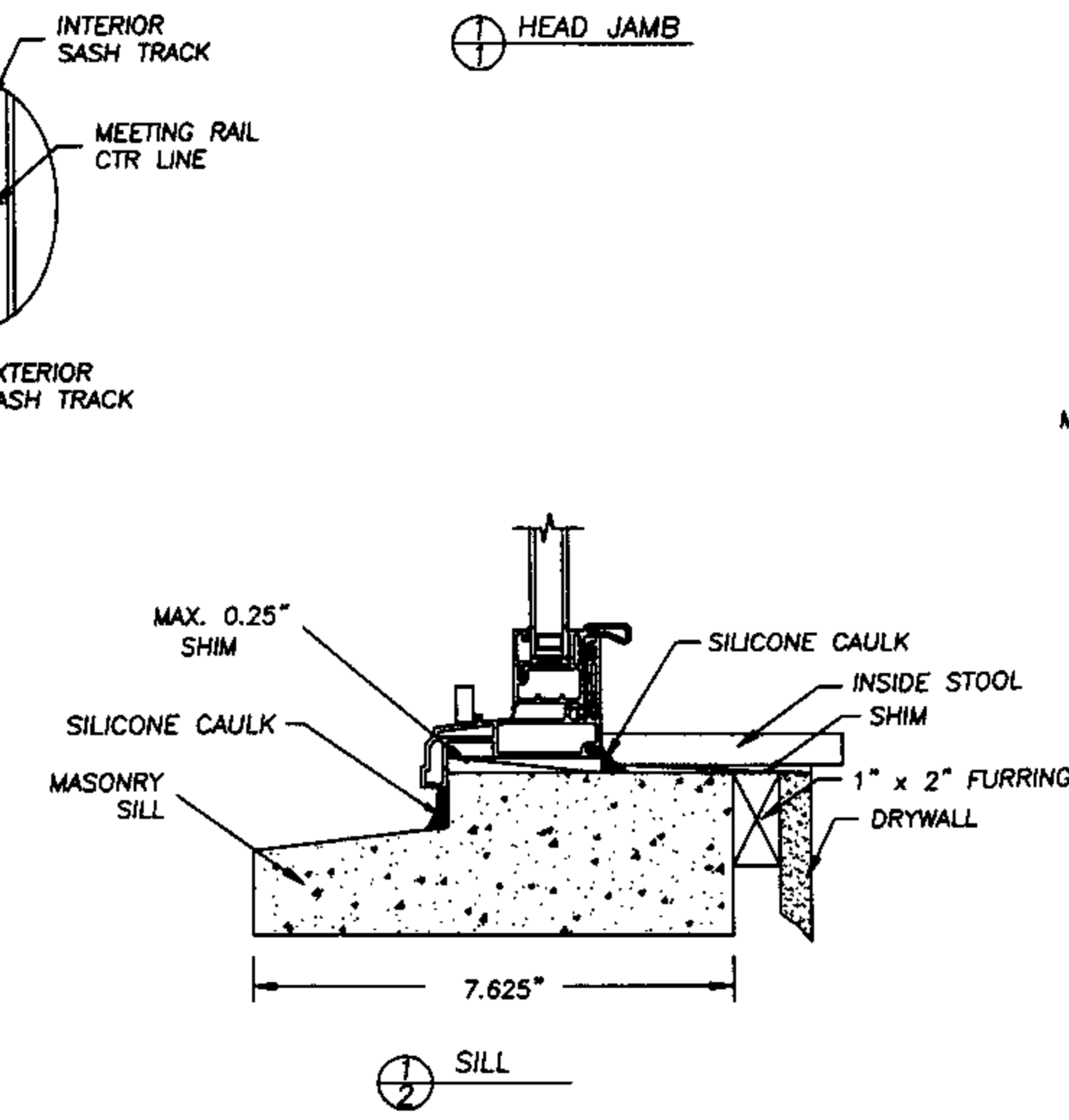
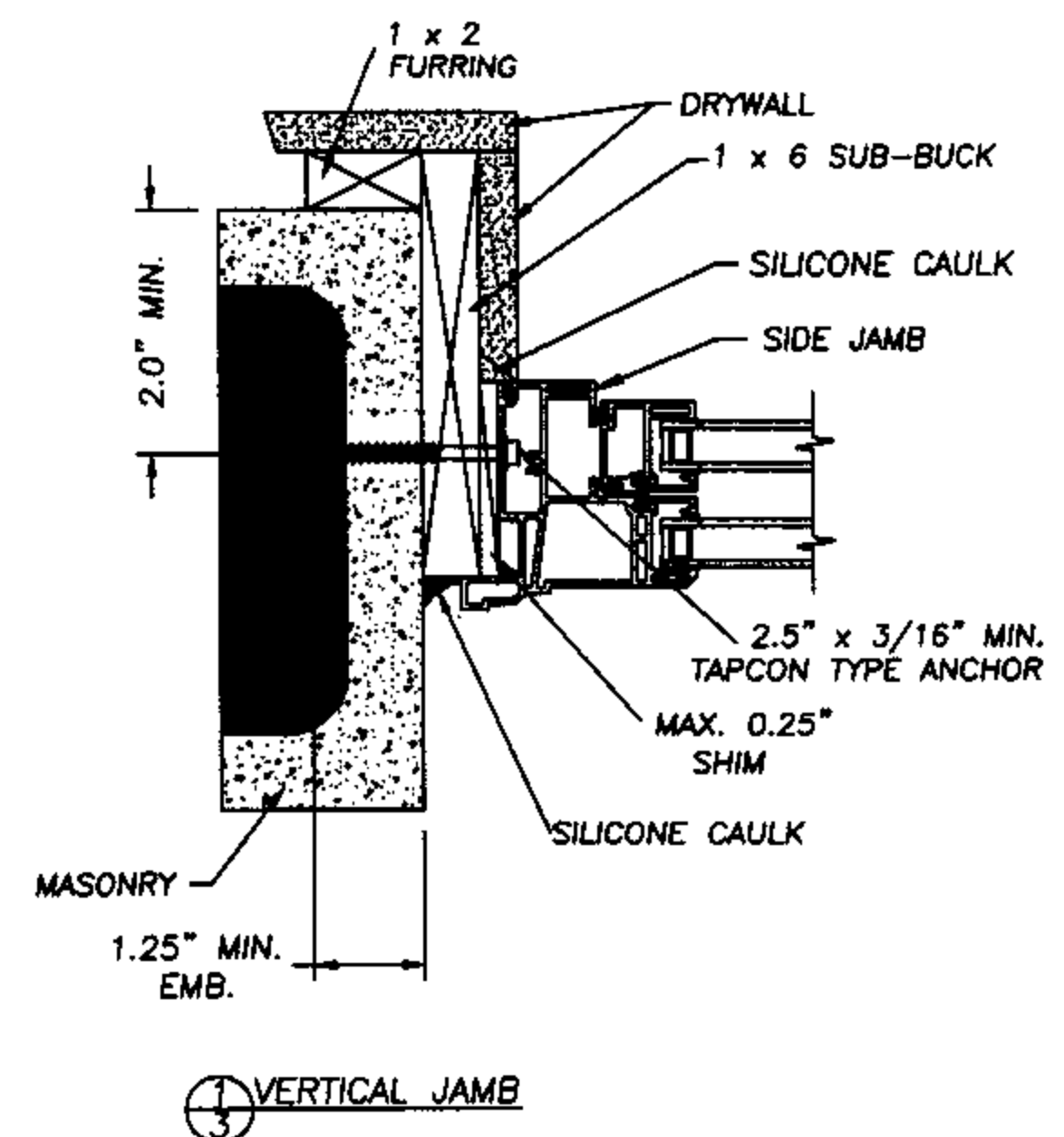
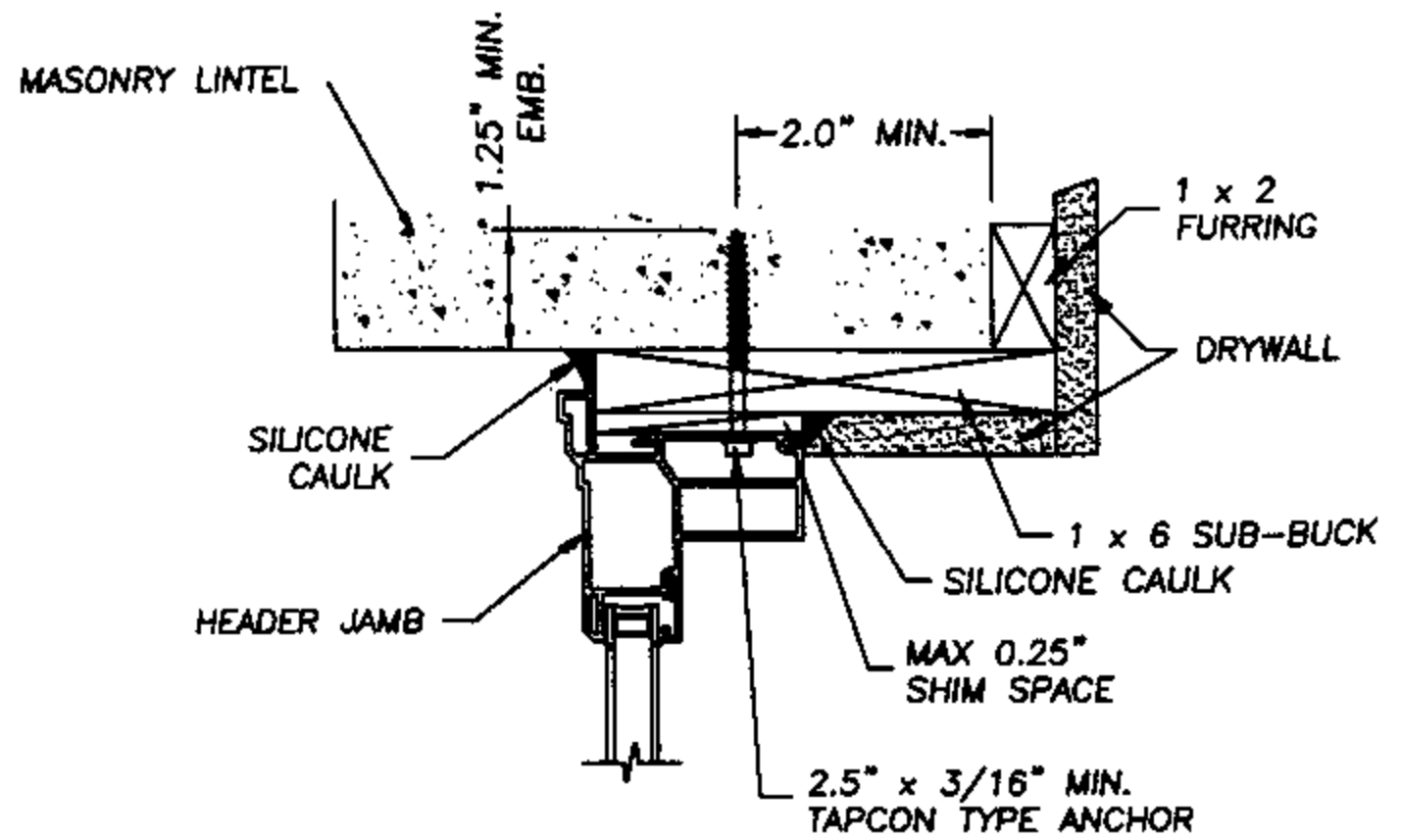
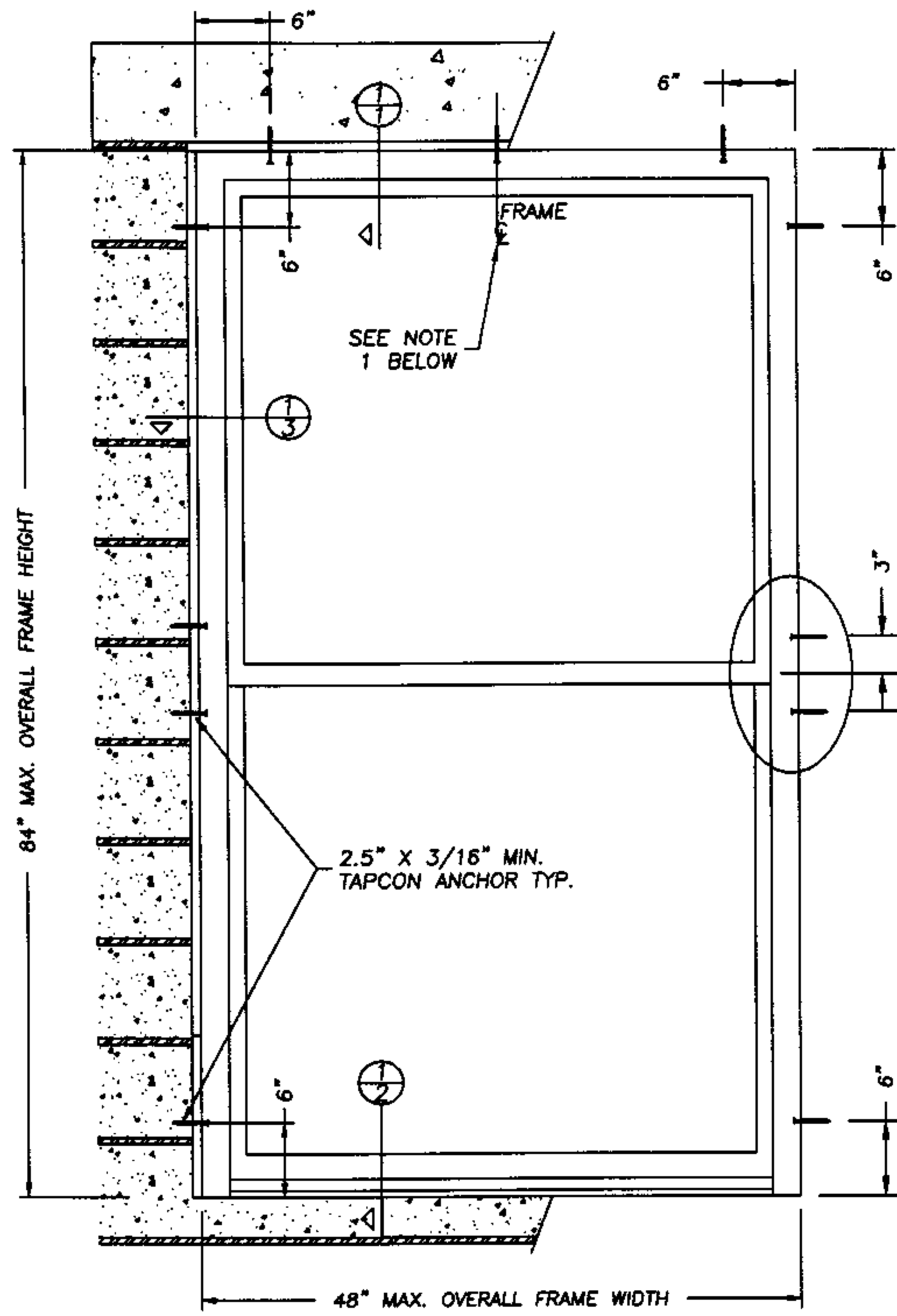

NOTE:

1. When installing a window that is 36" or less in width, the centerline screw at the head may be eliminated.
2. Wall dressing at exterior flanges By Others.
3. Adjust Tapcon anchor locations, if necessary, to maintain a minimum 2.0" clearance from mortar joints.

JULY 23, 2002
 Lyndon F. Schmidt
 Florida P. E. No. 43409
 19506 French Lace Drive
 Lutz, FL 33558

American Craftsman Windows
 P O Box 6029
 North Brunswick, NJ 08902
 PH. 800 299-9501

ANCHORING CROSS SECTIONS
 FOR 1X BUCK TO MASONRY
 SERIES 2900 SINGLE HUNG
 VINYL WINDOW

RW BUILDING
 CONSULTANTS, INC.
 813.659.9197

DATE: 6/13/02
 SCALE: N.T.S.
 DWG. BY: WLN
 CHK. BY: R.W.
 DRAWING NO.:
 AC-404-OC
 SHEET 2 OF 3

