

Silverline Building Products Corp.

SILVERLINE 2700 SERIES, MODEL 2710

MULLED SINGLE HUNG EXTRUDED VINYL WINDOW W/ALUMINUM MULLION

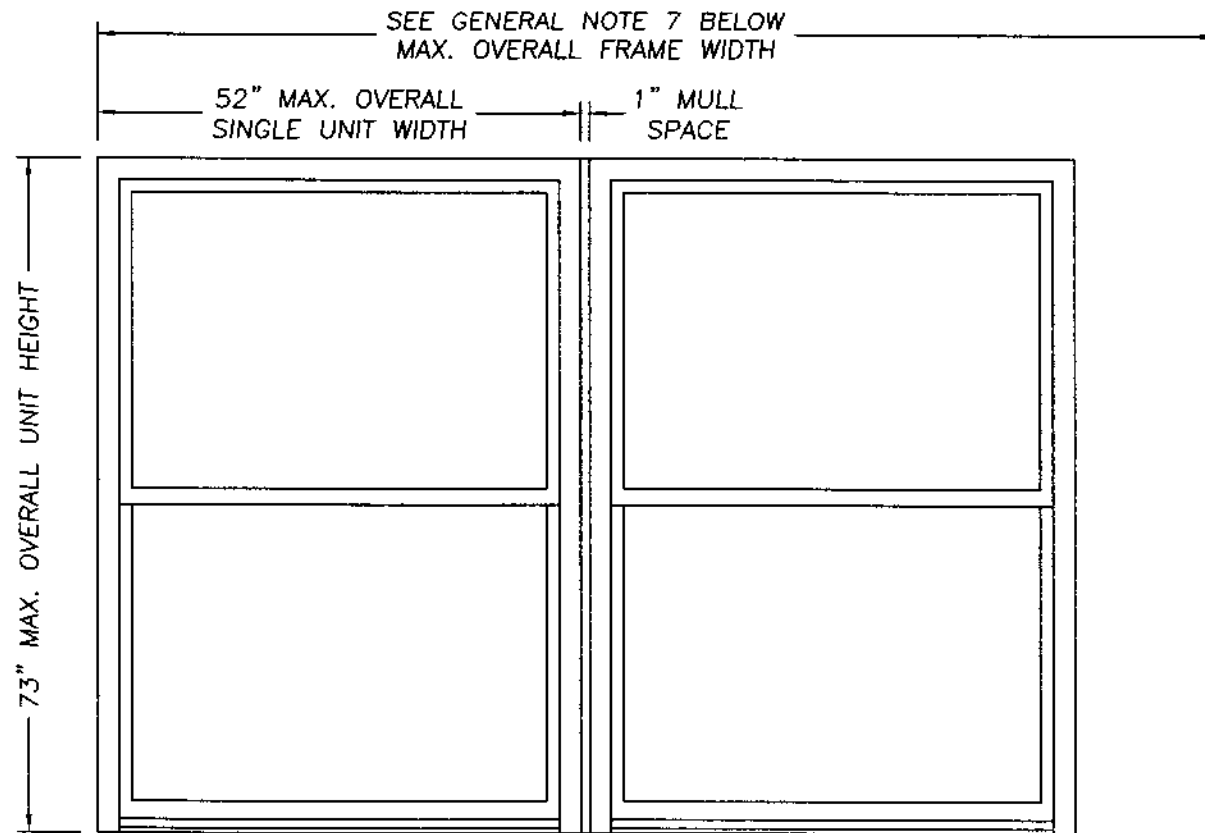

	OVERALL SINGLE UNIT WIDTH	52"	48"	44"	40"	36"
OVERALL UNIT HEIGHT						
73"		+35 -35	+37 -37	+38 -38	+41 -41	+43 -43
72"		+36 -36	+38 -38	+40 -40	+42 -42	+45 -45
68"		+42 -42	+44 -44	+46 -46	+48 -48	+51 -51
64"		+50 -50	+51 -51	+53 -53	+56 -56	+59 -59
62"		+54 -54	+56 -56	+58 -58	+60 -60	+60 -64

GENERAL NOTES

1. THIS PRODUCT IS DESIGNED TO COMPLY WITH THE FLORIDA BUILDING CODE.
2. PRODUCT ANCHORS SHALL BE AS LISTED AND SPACED AS SHOWN ON DETAILS.
3. WHEN THIS PRODUCT IS USED IN AN AREA REQUIRING WINDBORNE DEBRIS PROTECTION, FLORIDA BUILDING CODE APPROVED IMPACT RESISTANT SHUTTERS ARE REQUIRED.
4. MASONRY ANCHORING FOR 1x BUCK SEE SHEET 2 OF 4.
5. MASONRY ANCHORING FOR 2x BUCK SEE SHEET 3 OF 4.
6. SEE SHEET 4 OF 4 FOR MULLION DETAILS.
7. DOUBLE UNIT SHOWN IN ELEVATION ABOVE. CAN BE CONFIGURED IN MULTIPLE UNITS. SINGLE UNIT WIDTH CAN NOT EXCEED 52" x 73" IN ANY CONFIGURATION.
8. DESIGN PRESSURE CAN NOT EXCEED +60 (LIMITED BY THE SINGLE UNIT WATER TEST).

PRODUCT DESCRIPTION

1. VINYL SINGLE HUNG WINDOW WITH MITERED AND WELDED CORNERS.
2. THE HEAD AND SIDE JAMBS ARE EXTRUDED VINYL WITH AN EXTERIOR WALL THICKNESS OF 0.070" +/- 0.008".
3. ALL ACTIVE SASH MEMBERS REINFORCED WITH SOLID ALUMINUM BAR STOCK.
4. THE FIXED MEETING RAIL UTILIZES A ROLLED FORMED STEEL REINFORCEMENT.
5. ALL UNITS USE SILVERLINE MULLION #2711 AND #2712 MULLION COVER. BOTH THE MULLION AND MULLION COVER ARE EXTRUDED 6063-T6 ALUMINUM.
6. USE SILVERLINE ANCHORING PLATE #2713 0.063" ALUMINUM, (2) PER MULLION.

[Signature]
 September 20, 2002

Lyndon F. Schmidt
 Florida P. E. No. 43409

19506 French Lace Drive Lutz, FL 33558

Silverline Building Products Corp.
 One Silverline Drive
 North Brunswick, NJ 08902
 PH. 732.435.1000

PRODUCT: SILVERLINE 2710
 MULLED VINYL SINGLE HUNG
 WINDOW W/ALUM. MULL.
 PART OR ASSEMBLY:
 TYPICAL ELEVATION DESIGN
 PRESSURES & GENERAL NOTES

NO.	DATE	BY	REVISIONS

RW BUILDING
 CONSULTANTS, INC.
 813.659.9197

DATE: 08/13/02

SCALE: N.T.S.

DWG. BY: TJH

CHK. BY: RW

DRAWING NO.:

SL-415-OC

SHEET 1 OF 4

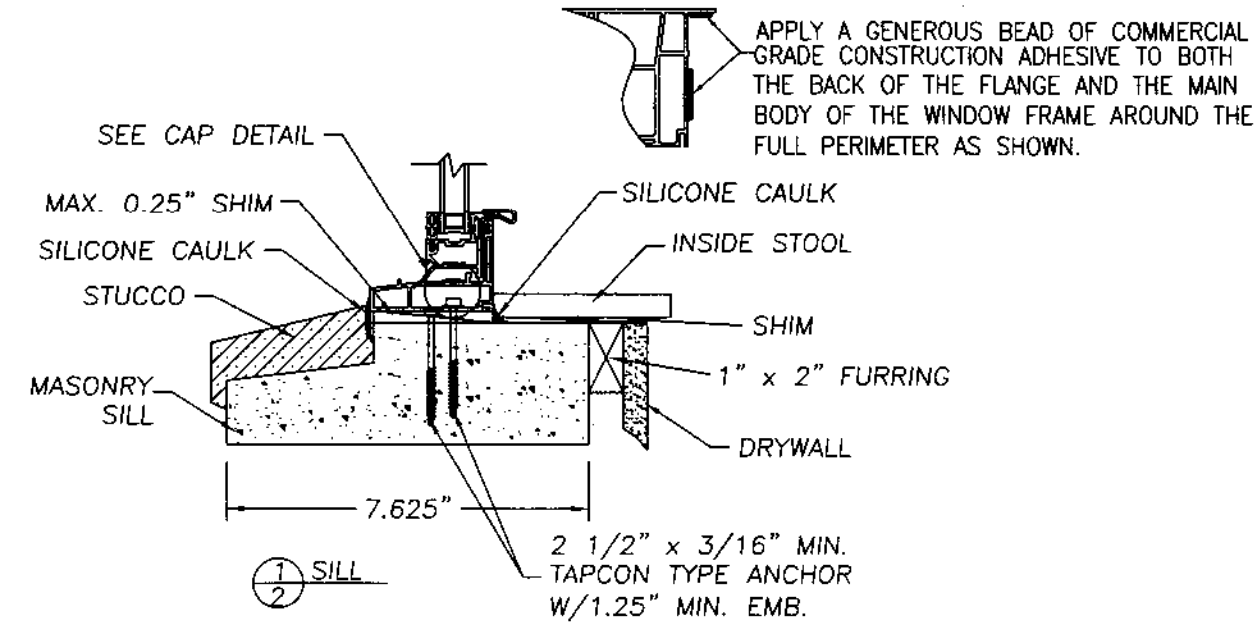
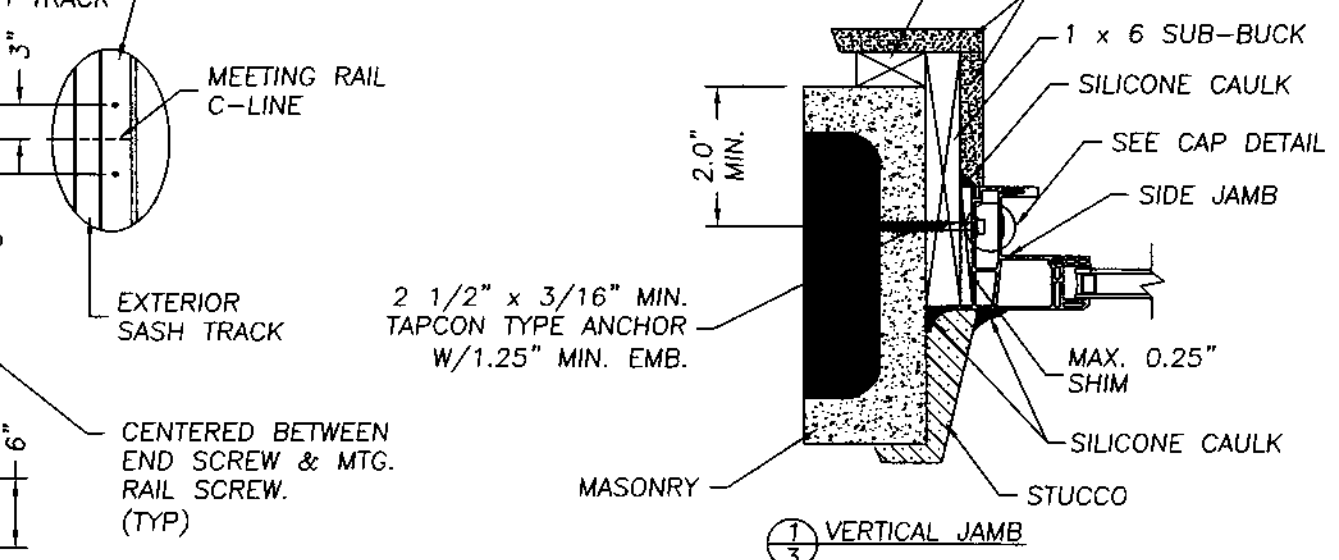
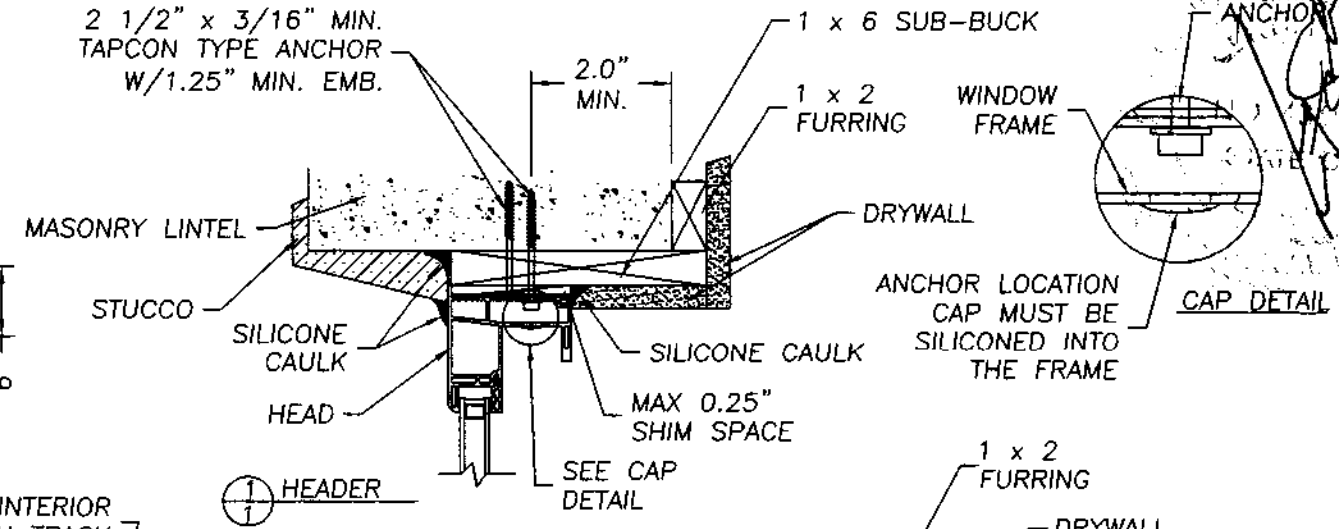
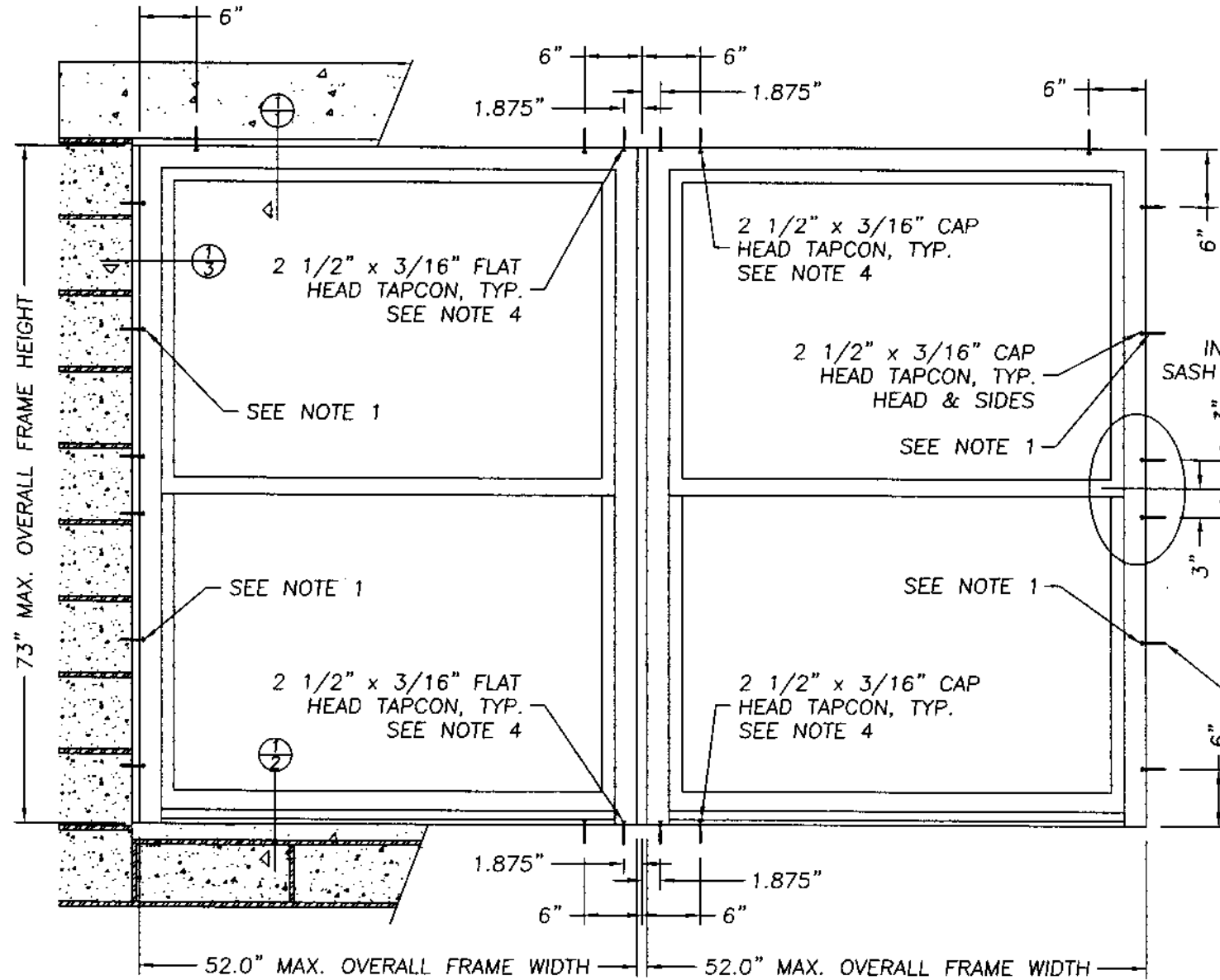

- NOTE:**
1. When installing a window that is 60" or less in overall height, eliminate the installation of this screw.
 2. Adjust Tapcon anchor locations, if necessary, to maintain a minimum 2.0" clearance from mortar joints.
 3. 52" is the maximum single unit width in the mulled application.
 4. The anchor 1.875" from the frame c-line is through the anchor plate. The anchor 6" from the frame c-line is through the window frame.

September 20, 2002
 Lyndon F. Schmidt
 Florida P. E. No. 43409
 19506 French Lace Drive
 Lutz, FL 33558

Silverline Building Products Corp.
 One Silverline Drive
 North Brunswick, NJ 08902
 PH. 732.435.1000

ANCHORING CROSS SECTIONS
 FOR 1X BUCK TO MASONRY
 SERIES 2710 MULLED VINYL
 SINGLE HUNG WINDOW

RW BUILDING
 CONSULTANTS, INC.
 813.659.9197

DATE: 08/13/02
 SCALE: N.T.S.
 DWG. BY: THJ
 CHK. BY: RW
 DRAWING NO.: SL-415-OC
 SHEET 2 OF 4

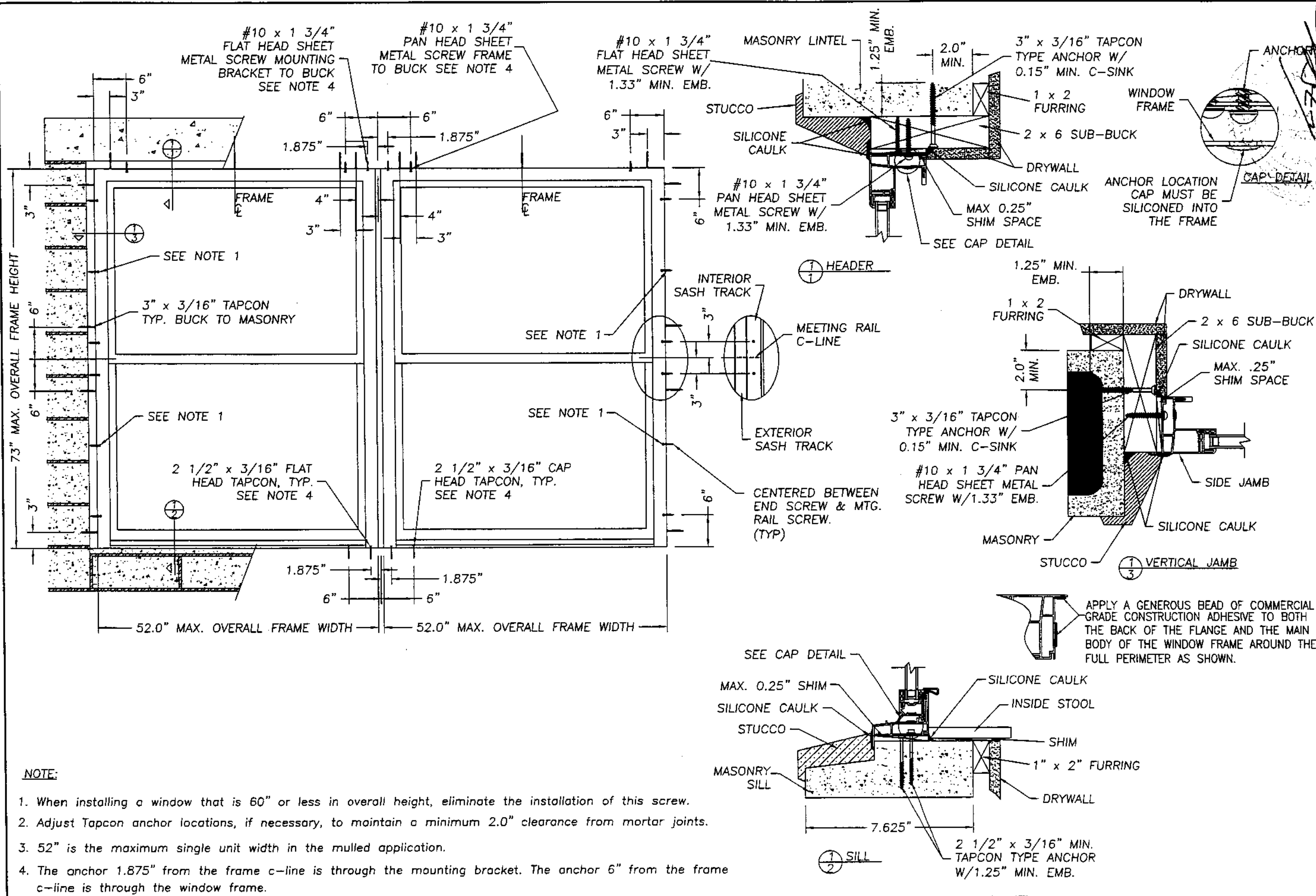

NOTE:

1. When installing a window that is 60" or less in overall height, eliminate the installation of this screw.
2. Adjust Tapcon anchor locations, if necessary, to maintain a minimum 2.0" clearance from mortar joints.
3. 52" is the maximum single unit width in the mullied application.
4. The anchor 1.875" from the frame c-line is through the mounting bracket. The anchor 6" from the frame c-line is through the window frame.

September 20, 2002

Lyndon F. Schmidt
 Florida P. E. No. 43409
 19506 French Lace Drive
 Lutz, FL 33558

Silverline Building Products Corp.
 One Silverline Drive
 North Brunswick, NJ 08902
 PH. 732.435.1000

ANCHORING CROSS SECTIONS
 FOR 2X BUCK TO MASONRY
 SERIES 2710 MULLED VINYL
 SINGLE HUNG WINDOW

RW BUILDING
 CONSULTANTS, INC.
 813.659.9197

DATE: 08/13/02

SCALE: N.T.S.

DWG. BY: THJ

CHK. BY: RW

DRAWING NO.:

SL-415-OC

SHEET 3 OF 4

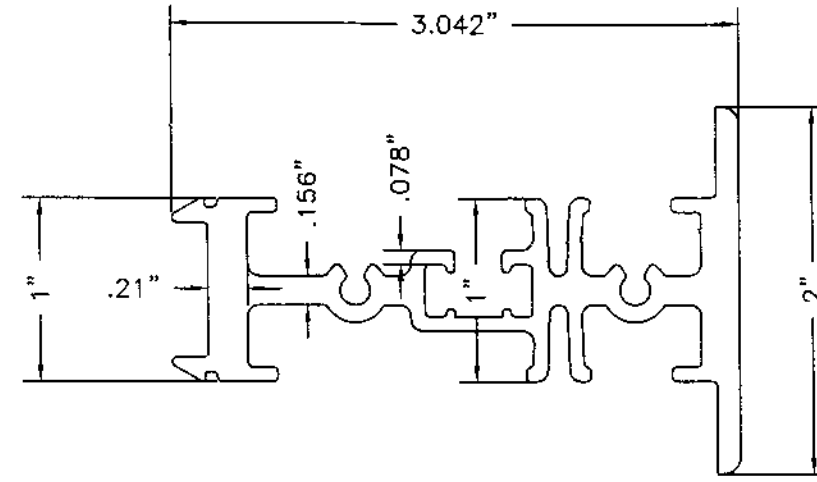
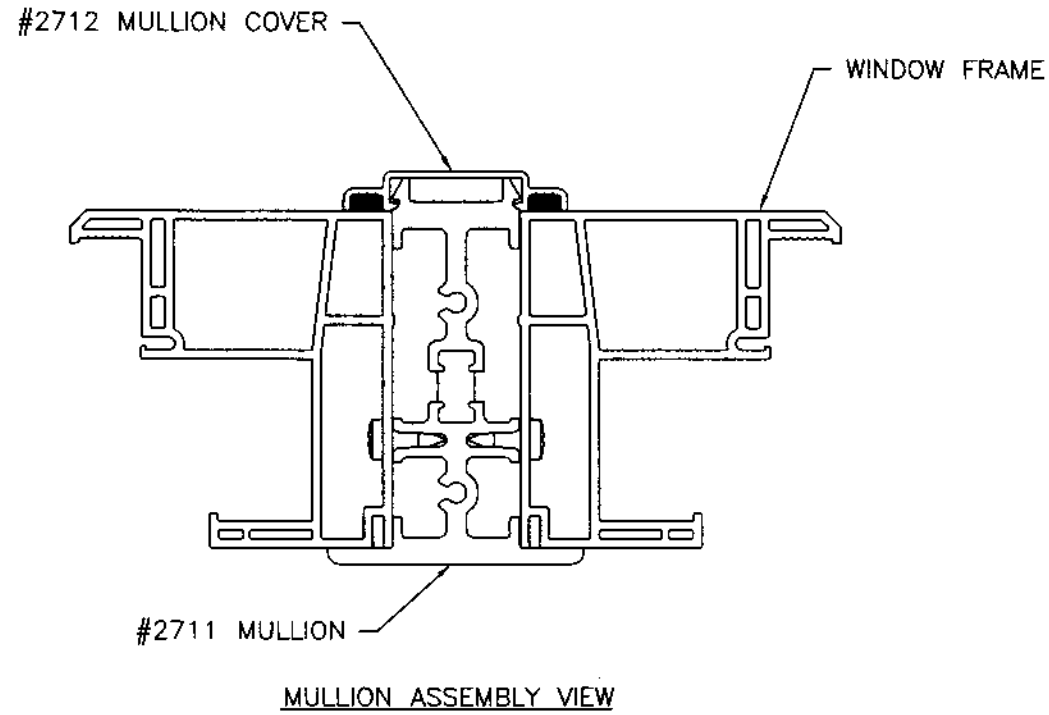

SILVERLINE MULLION #2711
EXTRUDED ALUMINUM 6063-T6

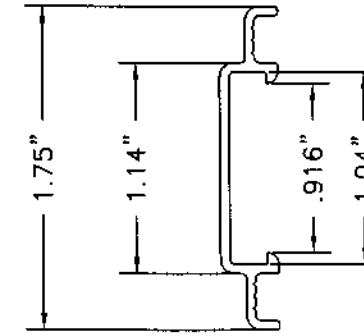

SILVERLINE MULLION COVER #2712
EXTRUDED ALUMINUM 6063-T6

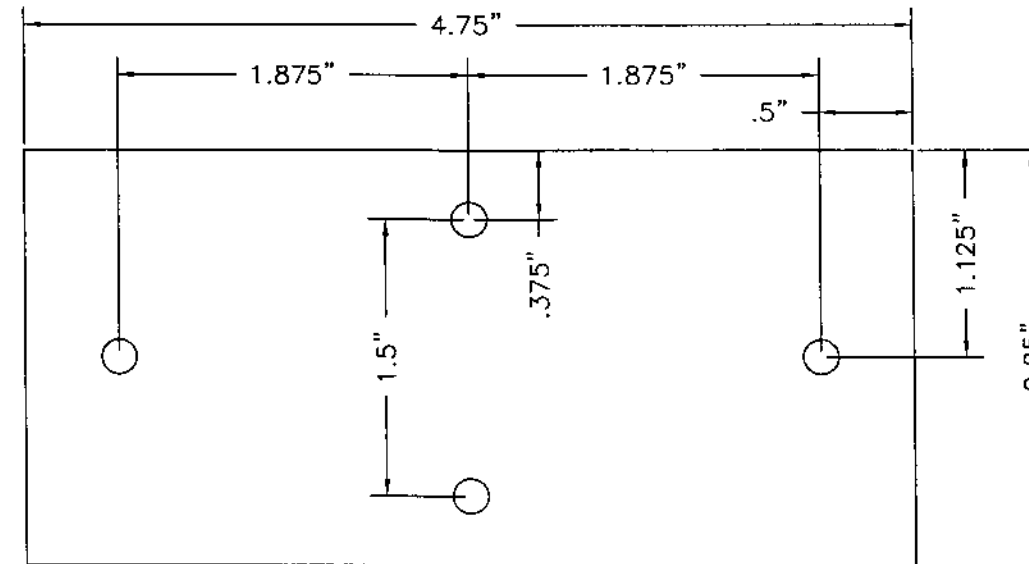
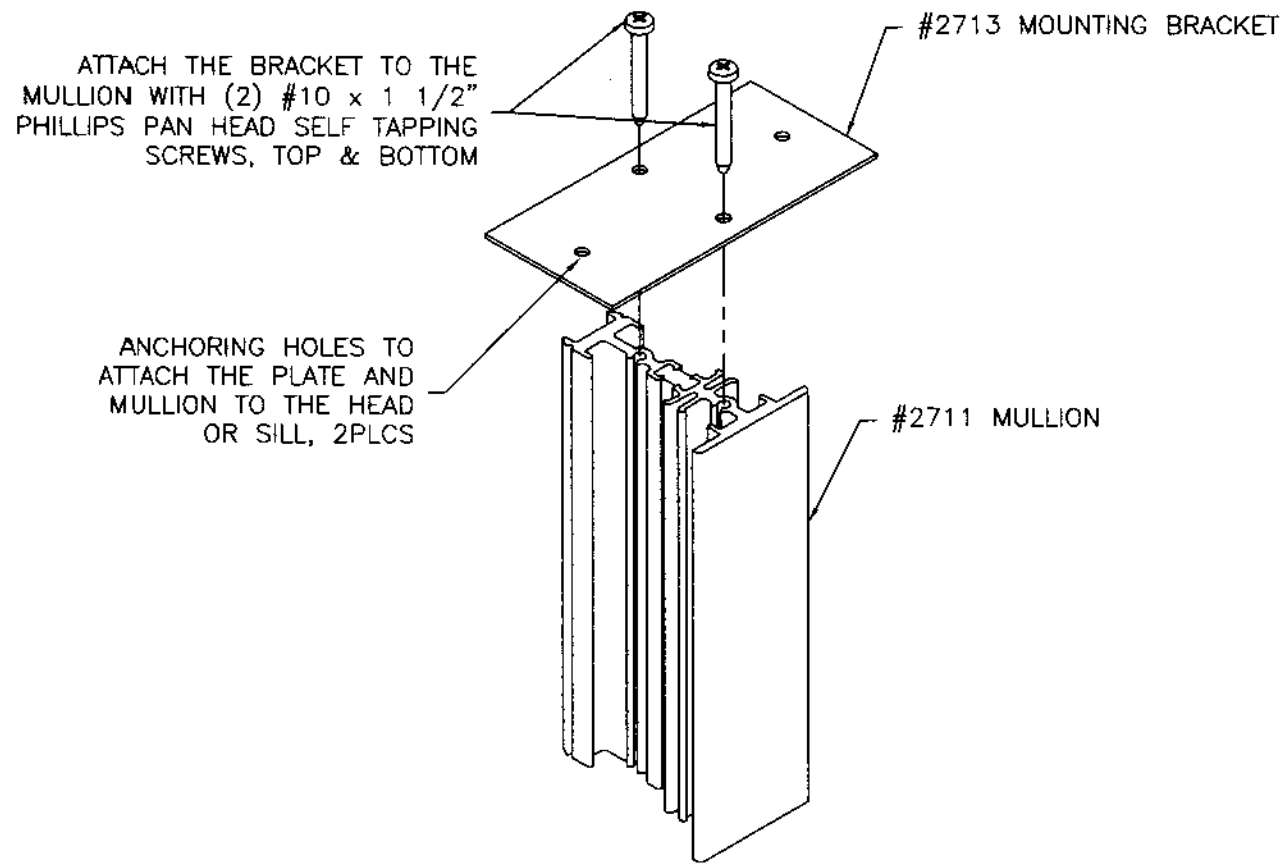

SILVERLINE MULLION MOUNTING BRACKET #2713
EXTRUDED ALUMINUM 6063-T6 0.063" THK.

RW

September 20, 2002

Lyndon F. Schmidt,
Florida P. E. No. 43409
19506 French Lace Drive
Lutz, FL 33558

Silverline Building Products Corp.
One Silverline Drive
North Brunswick, NJ 08902
PH. 732.435.1000

SILVERLINE 2710 MULLED
VINYL SINGLE HUNG WINDOW
MULL DETAILS AND ASSEMBLY

RW BUILDING
CONSULTANTS, INC.
813.659.9197

DATE: 08/13/02

SCALE: N.T.S.

DWG. BY: THJ

CHK. BY: RW

DRAWING NO.:

SL-415-OC

SHEET 4 OF 4