

CAULK PERIMETER BETWEEN WINDOW NAIL FIN & WOOD BUCK (ALL WAY AROUND)

8 Hex or Pan Head Woodscrews or # 10D Nails with Min. Imbedment as shown in Tables (All Way Around)

TYPICAL WOOD FRAME OPENING BY OTHERS

8 Hex or Pan Head Woodscrews or # 10D Nails with Min. Imbedment as shown in Tables (All Way Around)

TYPICAL WOOD FRAME OPENING BY OTHERS

CENTRAL FLORIDA B.O.A.F.

MANUFACTURER NAME:

DANVID

MASTER FILE # 1

1/4" SHIM MAX

JAMBS SECTION 2

HEAD

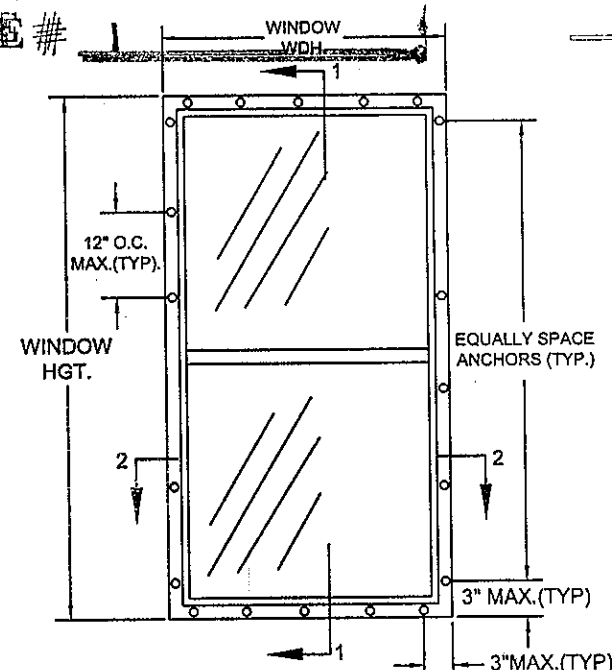
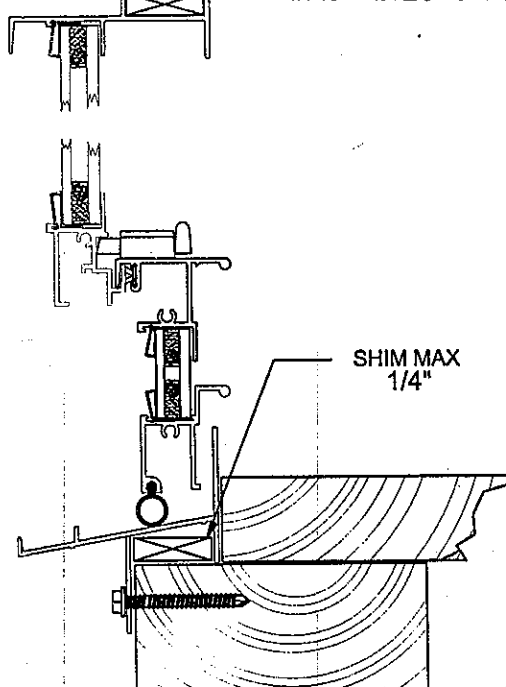

ELEVATION VIEWED FROM EXTERIOR

SECTION 1

SILL

YOUSEF LAVI, P.E.
CONSULTING ENGINEER
9550 FOREST LANE, SUITE #108
DALLAS, TEXAS 75243
T: (214)340-0049 F: (214)340-0067

Yousef Lavi

MAY 05 2003

CHANGE	DATE	DANVID WINDOW COMPANY		DANVID WINDOW COMPANY	
		DRAWN	ER	DATE	05/05/03
		APPVD		MAT'L	SCALE
		FASTENING AND ANCHORAGE INSTALLATIONS 300/2300 SERIES SH			SHEET
				A	1/2

SINGLE HUNG WINDOW ANCHOR CHART FOR
DANVID WINDOW COMPANY SERIES 300/2300
DESIGN PRESSURE 40 PSF

WINDOW SIZE (INCHES)	NO. OF #8 SCREWS REQUIRED IN FRAME 1" MIN. EMBEDMENT			NO. OF 0.128" DIA. NAILS REQUIRED IN FRAME 1 1/2" MIN. EMBEDMENT		
	WIDTH/HEIGHT	HEAD	SILL	AT EACH JAMB	HEAD	SILL
12 X 12	2	2	2	2	2	2
12 X 18	2	2	2	2	2	2
12 X 24	2	2	2	2	2	2
12 X 30	2	2	2	2	2	2
12 X 36	2	2	2	2	2	2
12 X 44	2	2	2	2	2	2
12 X 48	2	2	2	2	2	2
12 X 60	2	2	2	2	2	2
12 X 72	2	2	2	2	2	3
18 X 12	2	2	2	2	2	2
18 X 18	2	2	2	2	2	2
18 X 24	2	2	2	2	2	2
18 X 30	2	2	2	2	2	2
18 X 36	2	2	2	2	2	2
18 X 44	2	2	2	2	2	2
18 X 48	2	2	2	2	2	3
18 X 60	2	2	2	2	2	3
18 X 72	2	2	2	2	2	4
24 X 12	2	2	2	2	2	2
24 X 18	2	2	2	2	2	2
24 X 24	2	2	2	2	2	2
24 X 30	2	2	2	2	2	2
24 X 36	2	2	2	2	2	2
24 X 44	2	2	2	2	2	3
24 X 48	2	2	2	2	2	3
24 X 60	2	2	2	2	2	4
24 X 72	2	2	2	2	2	5
30 X 12	2	2	2	2	2	2
30 X 18	2	2	2	2	2	2
30 X 24	2	2	2	2	2	2
30 X 30	2	2	2	2	2	2
30 X 36	2	2	2	2	2	3
30 X 44	2	2	2	2	2	3
30 X 48	2	2	2	2	2	3
30 X 60	2	2	2	2	2	4
30 X 72	2	2	2	2	2	5

SINGLE HUNG WINDOW ANCHOR CHART FOR
DANVID WINDOW COMPANY SERIES 300/2300
DESIGN PRESSURE 40 PSF

WINDOW SIZE (INCHES)	NO. OF #8 SCREWS REQUIRED IN FRAME 1" MIN. EMBEDMENT			NO. OF 0.128" DIA. NAILS REQUIRED IN FRAME 1 1/2" MIN. EMBEDMENT		
	WIDTH/HEIGHT	HEAD	SILL	AT EACH JAMB	HEAD	SILL
36 X 12	2	2	2	2	2	2
36 X 18	2	2	2	2	2	2
36 X 24	2	2	2	2	2	2
36 X 30	2	2	2	2	2	2
36 X 36	2	2	2	2	2	3
36 X 44	2	2	2	2	2	3
36 X 48	2	2	2	2	2	4
36 X 60	2	2	2	2	2	5
36 X 72	2	2	2	3	2	6
44 X 12	2	2	2	2	2	2
44 X 18	2	2	2	2	2	2
44 X 24	2	2	2	2	2	2
44 X 30	2	2	2	2	2	3
44 X 36	2	2	2	2	2	3
44 X 44	2	2	2	3	3	4
44 X 48	2	2	2	3	3	4
44 X 60	2	2	2	3	3	6
44 X 72	2	2	2	3	3	7
48 X 12	2	2	2	2	2	2
48 X 18	2	2	2	2	2	2
48 X 24	2	2	2	2	2	2
48 X 30	2	2	2	2	2	3
48 X 36	2	2	2	3	3	3
48 X 44	2	2	2	3	3	4
48 X 48	2	2	2	3	3	5
48 X 60	2	2	2	3	3	6
48 X 72	2	2	2	3	4	7

GENERAL NOTES

- SHIM AS REQ'D. ADJACENT TO EACH INSTALLATION ANCHOR WITH LOAD SHIM MAX. ALLOWABLE SHIM STACK TO BE 1/4".
- WINDOW FRAME MATERIAL ALLOY 6063
- USE LATEX CAULK BEHIND WINDOW FIN AT HEAD, SILL & JAMBS.
- USE LATEX CAULK FOR PERIMETER SEAL AROUND EXTERIOR OF WINDOW FLANGE.
- GLASS THICKNESS MAY VARY PER THE REQUIREMENTS OF ASTM E1300 GLASS CHART
- WHERE WATER RESISTANCE TEST REQUIREMENT OF 15% OF DESIGN LOAD APPLIES, POSITIVE DESIGN LOADS WILL BE LIMITED TO 40.0 PSF DUE TO WATER TEST PRESSURE OF 6.0 PSF ACHIEVED IN TEST.
- INSTALLATION: FIN FRAME WINDOW IN SPRUCE PINE FIR (SPF) WOOD FRAME OPENING WITH TWO BY WOOD STUDS USING 0.128" DIA. NAILS OR #8 SCREW OF SUFFICIENT LENGTH TO PROVIDE MIN EMBEDMENT INTO SUBSTRATE AS SHOWN
- IF EXACT WINDOW SIZE IS NOT LISTED IN ANCHOR CHART, USE ANCHOR QUANTITY IN TABLES.

YOUSEF LAVI, P.E.
CONSULTING ENGINEER
9550 FOREST LANE, SUITE #108
DALLAS, TEXAS 75243
T: (214)340-0049 F: (214)340-0067

Yousef Lavi

MAY 05 2003

CHANGE	DATE	© DANVID WINDOW COMPANY						
		DANVID WINDOW COMPANY						
		DRAWN	ER	DATE	APPVD	MAT'L	SCALE	
				05/05/03			Not to Scale	
		ANCHOR CHART FOR 300/2300 SERIES SH					A	SHEET 2/2