

# Silverline Building Products Corp.

SILVERLINE 2710 SERIES  
EXTRUDED VINYL SINGLE HUNG WINDOWS

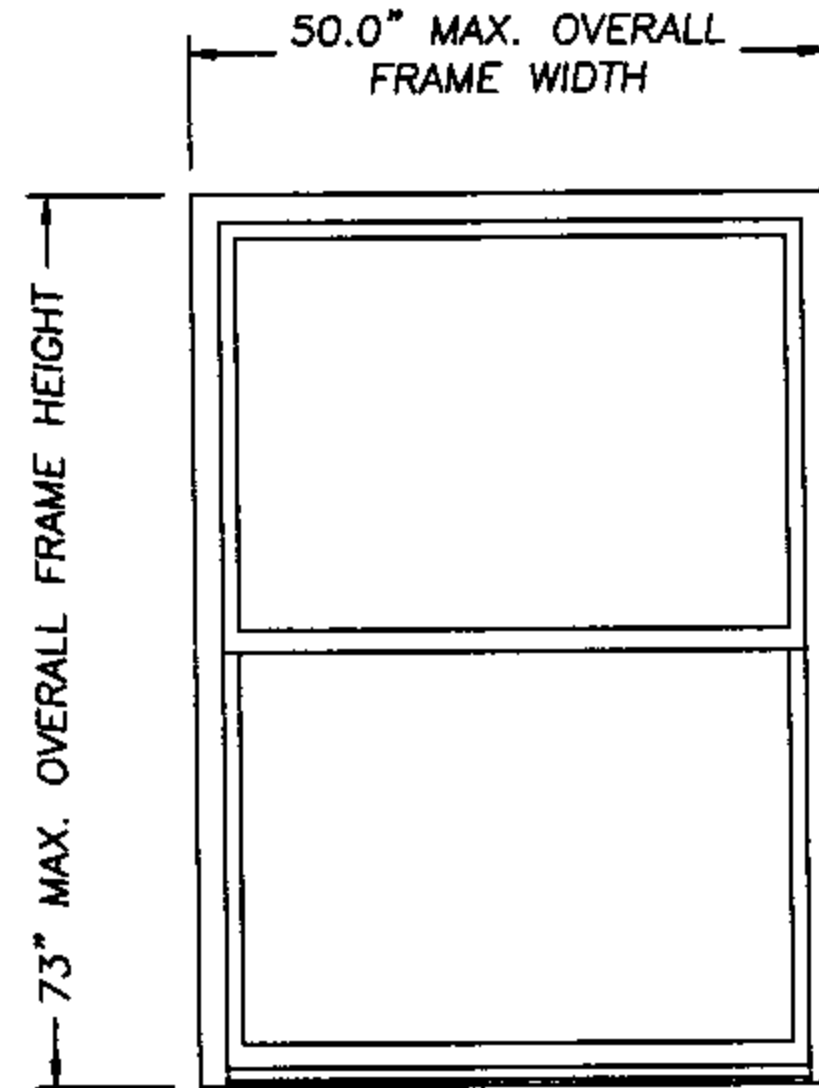

$\frac{O}{X}$

DESIGN PRESSURE RATING
POS. 60.0    NEG. 60.0
GLASS TABLE
5/8" INSULATED GLASS
1/8" ANN. - AIR SPACE - 1/8" ANN.

### GENERAL NOTES

1. THIS PRODUCT IS DESIGNED TO COMPLY WITH THE FLORIDA BUILDING CODE.
2. PRODUCT ANCHORS SHALL BE AS LISTED AND SPACED AS SHOWN ON DETAILS.
3. WHEN THIS PRODUCT IS USED IN AN AREA REQUIRING WINDBORNE DEBRIS PROTECTION, FLORIDA BUILDING CODE APPROVED IMPACT RESISTANT SHUTTERS ARE REQUIRED.
4. MASONRY ANCHORING FOR 1x BUCK SEE SHEET 2 OF 3.
5. MASONRY ANCHORING FOR 2x BUCK SEE SHEET 3 OF 3.

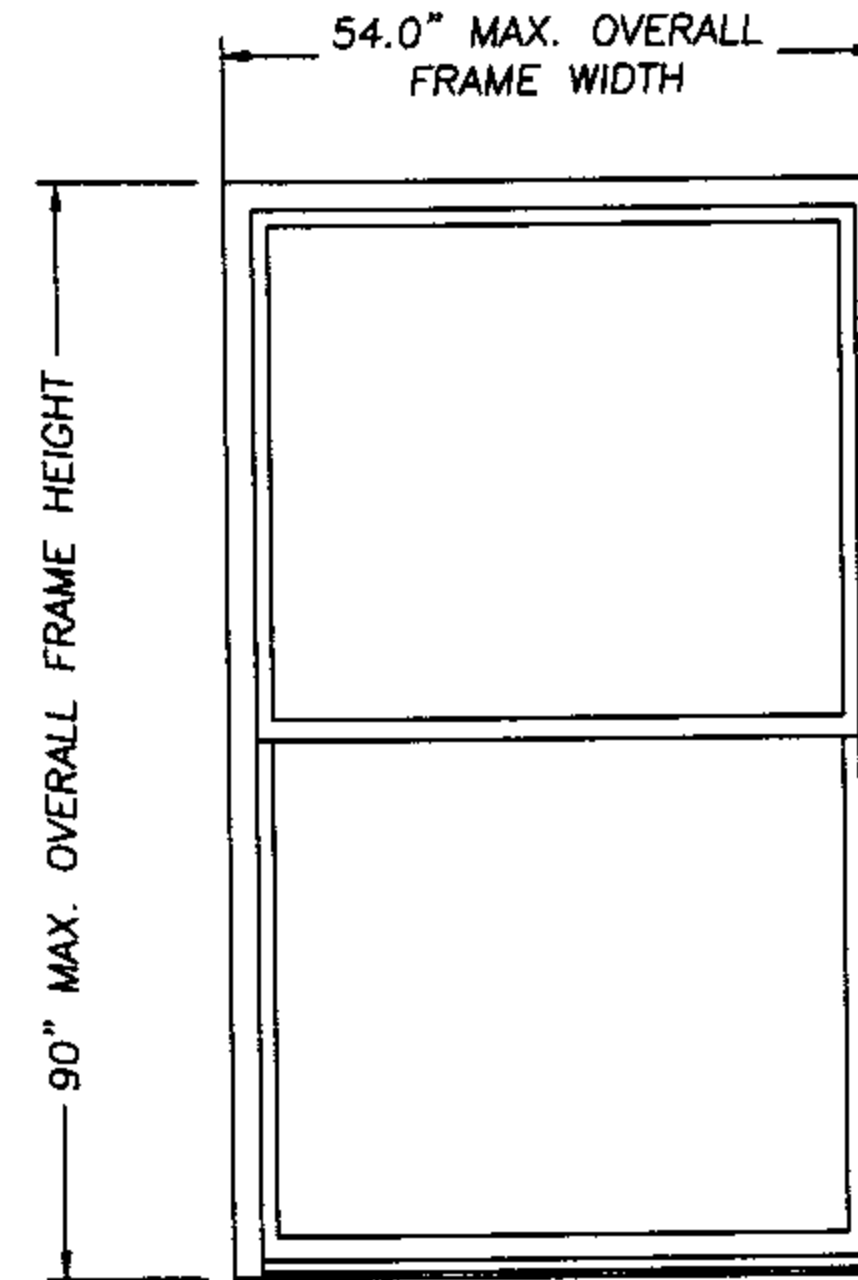

$\frac{O}{X}$

DESIGN PRESSURE RATING
POS. 40.0    NEG. 40.0
GLASS TABLE
5/8" INSULATED GLASS
1/8" ANN. - AIR SPACE - 1/8" ANN.

### PRODUCT DESCRIPTION

1. VINYL SINGLE HUNG WINDOW WITH MITERED AND WELDED CORNERS.
2. THE HEAD AND SIDE JAMBS ARE EXTRUDED VINYL WITH AN EXTERIOR WALL THICKNESS OF 0.070" +/- 0.008".
3. THE ACTIVE MEETING STILE IS REINFORCED WITH A 0.055" THICK ROLL-FORMED STEEL TUBE.

*[Signature]*  
JULY 23, 2002

Lyndon F. Schmidt  
Florida P. E. No. 43409  
19506 French Lace Drive    Lutz, FL 33558

**Silverline Building Products Corp.**  
One Silverline Drive  
North Brunswick, NJ 08902  
PH. 732.435.1000

PRODUCT: SILVERLINE  
EXTRUDED VINYL  
SINGLE HUNG WINDOW  
PART OR ASSEMBLY:  
GENERAL NOTES &  
TYPICAL ELEVATIONS

NO.	DATE	BY	REVISIONS

**RW** BUILDING  
CONSULTANTS, INC.  
813.659.9197

DATE: 6/13/02  
SCALE: N.T.S.  
DWG. BY: WLN  
CHK. BY: RW  
DRAWING NO.:  
SL-401-OC  
SHEET 1 OF 3

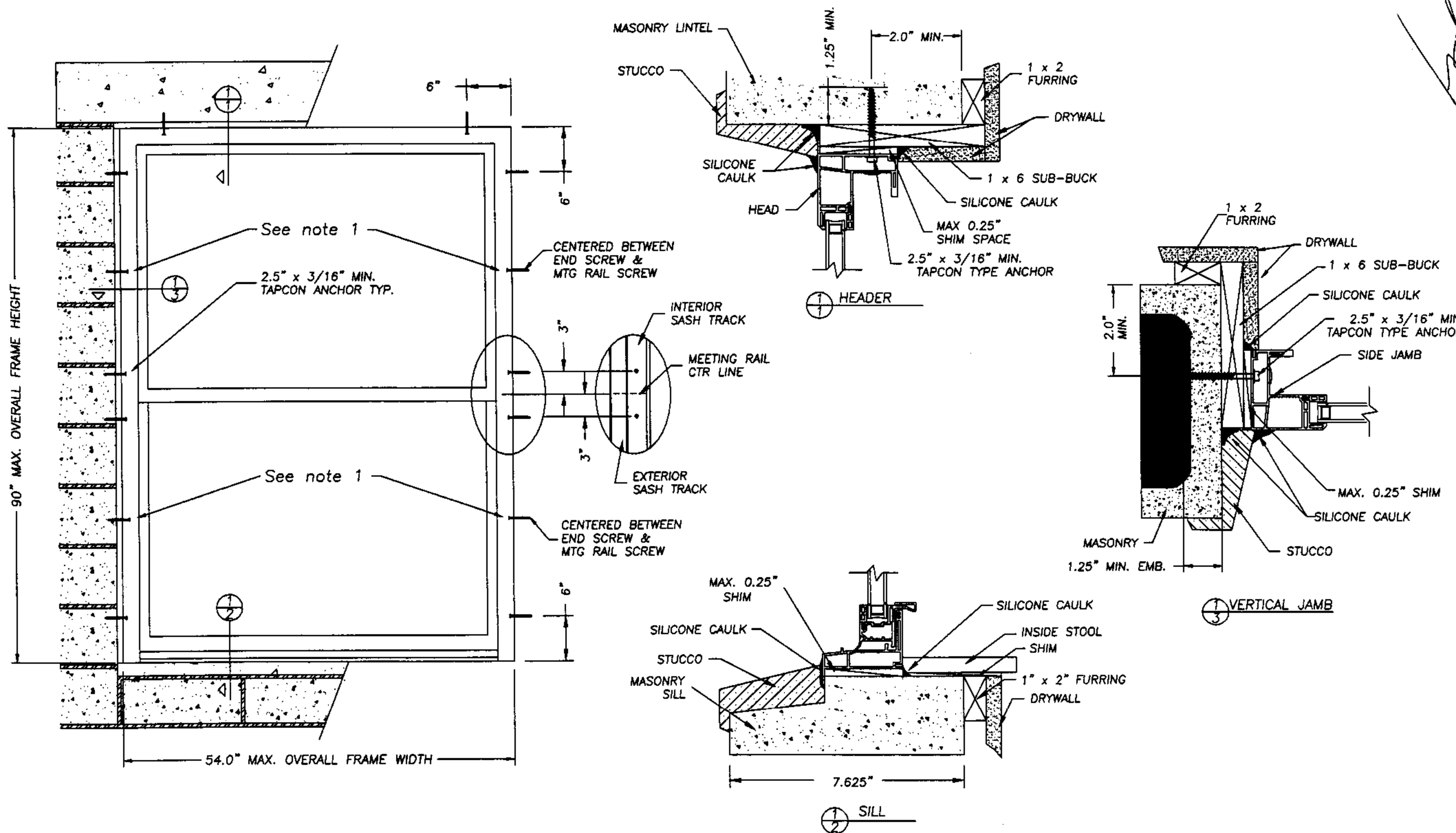

**NOTE:**

1. When installing a window that is 60" or less in overall height, eliminate the installation of this screw.
2. Adjust Tapcon anchor locations, if necessary, to maintain a minimum 2.0" clearance from mortar joints.

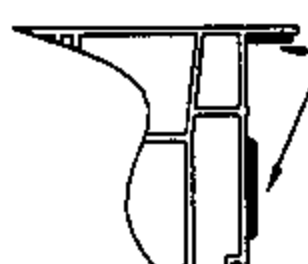

APPLY A GENEROUS BEAD OF COMMERCIAL GRADE CONSTRUCTION ADHESIVE TO BOTH THE BACK OF THE FLANGE AND THE MAIN BODY OF THE WINDOW FRAME AROUND THE FULL PERIMETER AS SHOWN.

JULY 23, 2002  
 Lyndon F. Schmidt  
 Florida P. E. No. 43409  
 19506 French Lace Drive  
 Lutz, FL 33558

**Silverline Building Products Corp.**  
 One Silverline Drive  
 North Brunswick, NJ 08902  
 PH. 732.435.1000

ANCHORING CROSS SECTIONS  
 FOR 1X BUCK TO MASONRY  
 SERIES 2710 SINGLE HUNG  
 VINYL WINDOW

**RW** BUILDING  
 CONSULTANTS, INC.  
 813.659.9197

DATE: 6/13/02  
 SCALE: N.T.S.  
 DWG. BY: WLN  
 CHK. BY: R.W.  
 DRAWING NO.:  
 SL-401-0C  
 SHEET 2 OF 3

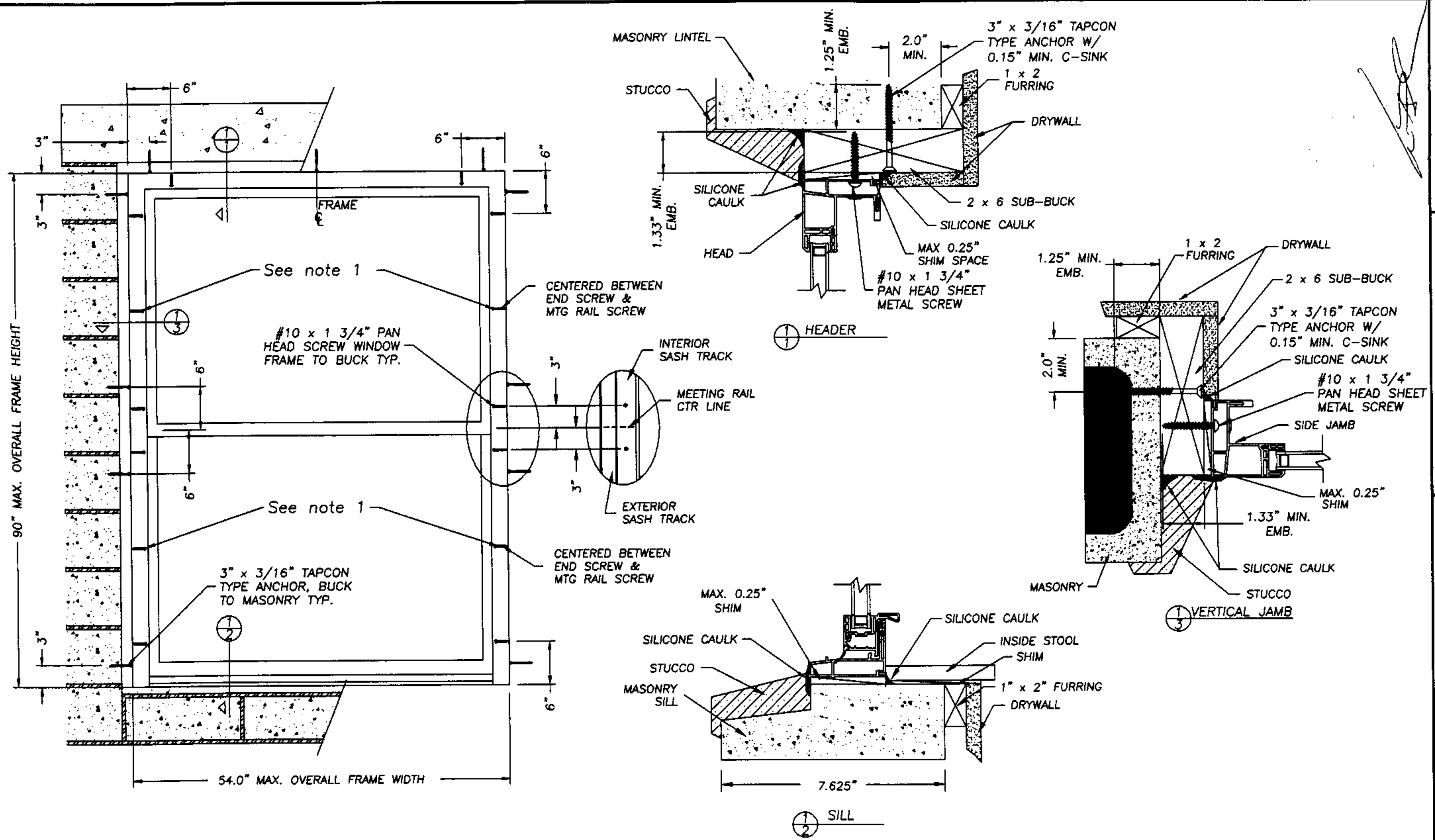

**NOTE:**

1. When installing a window that is 60" or less in overall height, eliminate the installation of this screw.
2. Adjust Tapcon anchor locations, if necessary, to maintain a minimum 2.0" clearance from mortar joints.

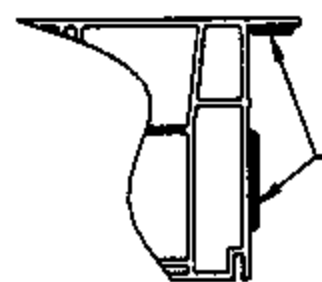

APPLY A GENEROUS BEAD OF COMMERCIAL GRADE CONSTRUCTION ADHESIVE TO BOTH THE BACK OF THE FLANGE AND THE MAIN BODY OF THE WINDOW FRAME AROUND THE FULL PERIMETER AS SHOWN.

JULY 23, 2002  
 Lyndon F. Schmidt  
 Florida P. E. No. 43409  
 19506 French Lace Drive  
 Lutz, FL 33558

**Silverline Building Products Corp.**  
 One Silverline Drive  
 North Brunswick, NJ 08902  
 PH. 732.435.1000

ANCHORING CROSS SECTIONS  
 FOR 2X BUCK TO MASONRY  
 SERIES 2710 SINGLE HUNG  
 VINYL WINDOW

**RW** BUILDING  
 CONSULTANTS, INC.  
 813.659.9197

DATE: 6/13/02  
 SCALE: N.T.S.  
 DWG. BY: WLN  
 CHK. BY: R.W.  
 DRAWING NO.:  
 SL-401-0C  
 SHEET 3 OF 3