

Figure 1: Window as Tested (1) and Compared Window (2)

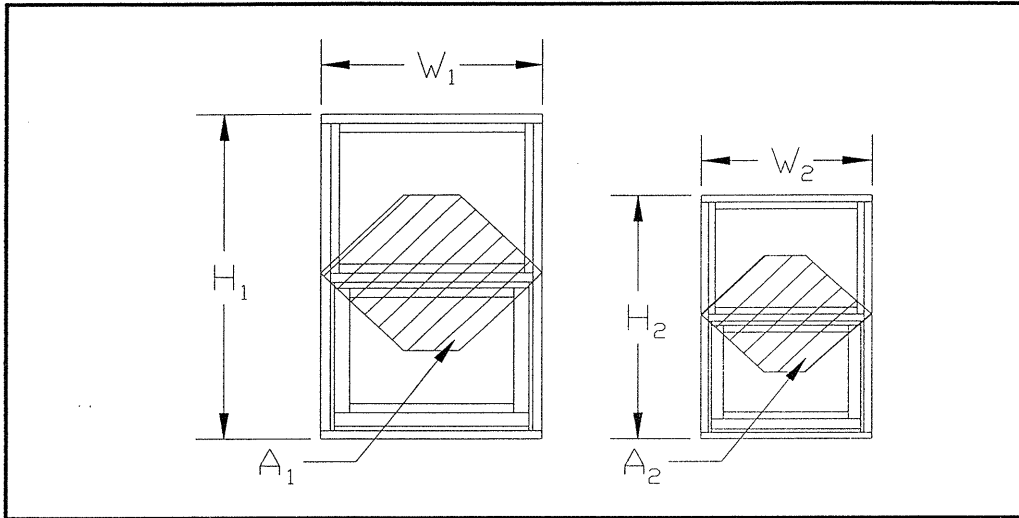

Table 1: Values to be Calculated.

	Tested Unit (1)	Compared Unit (2)
Width	W_1	W_2
Height	H_1	H_2
DP from Test Data	P_1	NA
Area	A_1	A_2
K	N/A	K_2
K_F	N/A	K_{F2}
K_D	N/A	K_{D2}
Concentrated DP	N/A	P_2
Fiber Stress DP	N/A	P_2
Deflection DP	N/A	P_2
Design Pres. (DP)	P_1	P_2

Formulas used to obtain lowest Comparable Design Pressure:

$$K_2 = (P_1 \times A_1) / 2$$

$$K_{F2} = (24 - (24 \times K_2)) / (3 - (4 \times K_2^2))$$

$$K_{D2} = (1920 - (1920 \times K_2)) / (25 - (40 \times K_2^2) + (16 \times K_2^4))$$

$$\text{Concentrated Load, } P_2 = (P_1 \times A_1) / A_2$$

$$\text{Fiberstress, } P_2 = (P_1 \times A_1 \times L_1 \times K_{F2}) / (A_2 \times L_2 \times K_{F1})$$

$$\text{Deflection, } P_2 = (P_1 \times A_1 \times L_1^2 \times K_{D2}) / (A_2 \times L_2^2 \times K_{D1})$$

DP of Compared Unit = Lowest of above 3 values for P_2

Notes:

Calculations to be performed in both positive and negative load directions.

Formulas and Calculations based on AAMA 203-98.

Negative Load DP is limited by the maximum Water Test Pressure (WTP).

Design Pressure X 1.5 = Structural Test Pressure

All pressures in psf.

James B. Whittum, P.E.

FL # 0027689

7519 Oakvista Cir.

Tampa, Florida 33634

813-889-7977

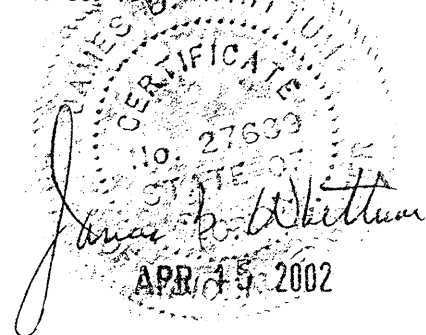



Formulas and Methods for Determining Maximum Wind Loads on Mullions

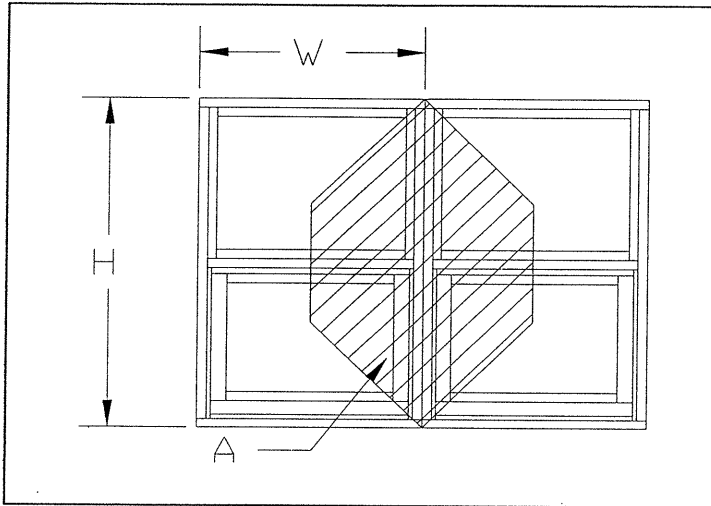

Use Beam Deflection Formula:

$$d = (5 \times F \times L^3) / (384 \times E \times I)$$

Where:

- d = Deflection (in), limited to L/175
- q = Load, Design Pressure (lbs/ft²)
- L = Length (span) of Mullion (in)
- E = Modulus of Elasticity (10,000,000 lbs/in²)
- I = Inertia (in⁴)
- A = Mullion Load Area (ft²)
- F = q X A (lbs)

Solve for F and divide by Area to obtain Maximum Design Pressure of Mull.

Check Moment on Mullion:

$$(W \times L^2) / 8 < 0.9 \times F_y \times S$$

Where:

- W = q X L (lbs/ft)
- C = Distance to Neutral Axis of Mullion (in)
- S = I / C (in³)
- F_y = 15,000 (lbs/in²) for 6063-T5 Aluminum

Check Fastener Requirements:

$$W / \# \text{ of fasteners} < \text{Maximum Fastener Load}$$

Where:

- W = Load (lbs)
- Max. Fastener Load is a value of the fastener and substrate.

Notes:

Units may require conversion for consistency.
Design Pressure used, for a safety factor of 1.5.
May also be applied to horizontal mullions.

James B. Whittum, P.E.
FL # 0027689
7519 Oakvista Cir.
Tampa, Florida 33634
813-889-7977

