

FIBER CLASSIC / SMOOTH STAR®

OPAQUE INSULATED FIBERGLASS DOOR
OUT-SWING / IN-SWING 8-0 UNITS W/ & W/OUT SIDELITES

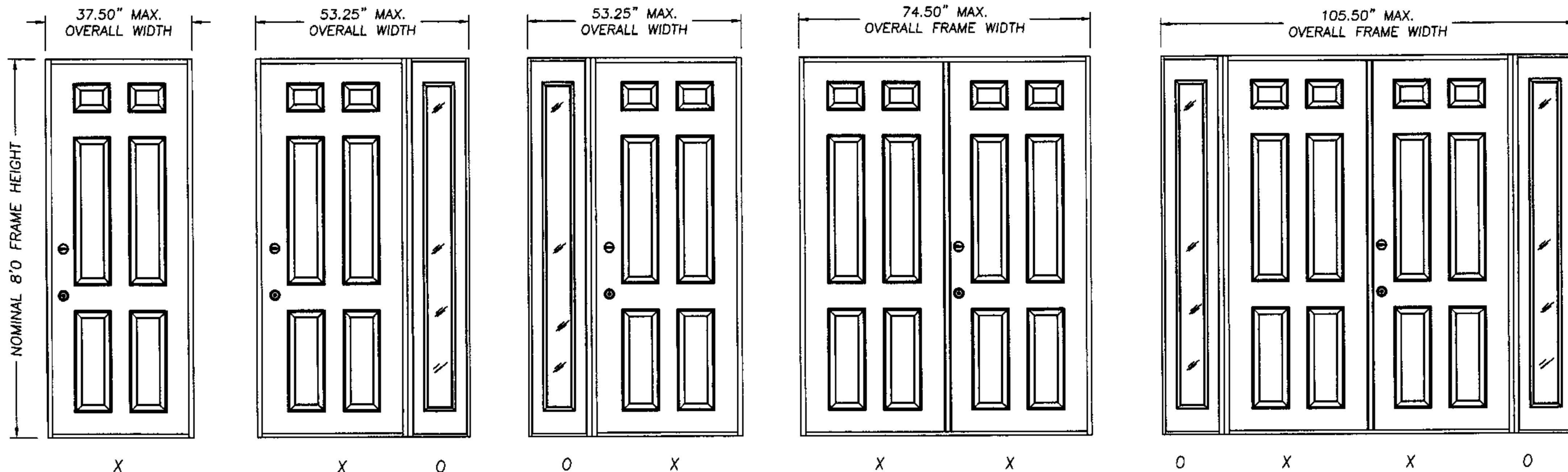

DESIGN PRESSURE RATING
OUT-SWING / IN-SWING POS. 67.0 NEG. 67.0

DESIGN PRESSURE RATING
OUT-SWING / IN-SWING POS. 47.0 NEG. 47.0

DESIGN PRESSURE RATING
OUT-SWING / IN-SWING POS. 47.0 NEG. 47.0

ASTRAGAL TYPE	DESIGN PRESSURE RATING
Coastal Alum. Astragal	OUT-SWING / IN-SWING POS. 47.0 NEG. 47.0
* Standard Alum. Astragal	OUT-SWING / IN-SWING POS. 40.0 NEG. 40.0

ASTRAGAL TYPE	DESIGN PRESSURE RATING
Coastal Alum. Astragal	OUT-SWING / IN-SWING POS. 47.0 NEG. 47.0
* Standard Alum. Astragal	OUT-SWING / IN-SWING POS. 40.0 NEG. 40.0

GENERAL NOTES

- THIS PRODUCT IS DESIGNED TO COMPLY WITH THE FLORIDA BUILDING CODE.
- PRODUCT ANCHORS SHALL BE AS LISTED AND SPACED AS SHOWN ON DETAILS.
- THE UNITS REQUIRE WINDBORNE DEBRIS EXTERNAL PROTECTION AS DESCRIBED IN SECTION 1626.1 OF THE FLORIDA BUILDING CODE WHEN USED IN WINDBORNE DEBRIS AREAS.
- FOR INSWING MASONRY ANCHORING SEE SHEET 2 OF 4.
- FOR OUTSWING MASONRY ANCHORING SEE SHEET 3 OF 4.
- FOR INSWING/OUTSWING WOOD STUD ANCHORING SEE SHEET 4 OF 4.

PRODUCT DESCRIPTION

- THE DOOR FACE SHEETS ARE FIBER CLASSIC (0.110") SMOOTH STAR (0.070")
- THE STILES AND RAILS ARE WOOD CONSTRUCTION.
- THE INTERIOR DOOR CAVITY IS URETHANE.
- THE SIDELITE GLAZING IS 0.5" INSULATED TEMPERED GLASS BY THERMA-TRU.
- THE WOOD JAMBS ARE A MIN. 4-9/16".
- THE THRESHOLD IS AN ALUMINUM BUMP FACE TYPE (OUTSWING) OR AN ALUMINUM SADDLE TYPE (INSWING).
- THE STANDARD ALUMINUM ASTRAGAL UTILIZES 18.875" LONG x 0.312" DIA. STEEL ROD WITH A 17.375" LONG ALUMINUM SLIDE ROD REINFORCEMENT BAR AT THE TOP AND A 7.5" LONG x 0.312" DIA. STEEL ROD WITH A 6.0" LONG ALUMINUM SLIDE REINFORCEMENT BAR AT THE BOTTOM.
- ALL LATCHBOLT AND DEADBOLT HARDWARE MUST BE CYLINDRICAL GRADE II WITH A 161 EDGE PREP AND A MINIMUM 1.0" DEADBOLT THROW.

 Lyndon F. Schmidt
 Florida P. E. No. 43409
 19506 French Lace Drive Lutz, FL 33558

THERMA-TRU CORPORATION
 1687 WOODLANDS DRIVE
 MAUMEE, OHIO
 PH. (800) 537-8827

PRODUCT: WOOD EDGE FIBERGLASS DOOR
 OPAQUE W/WO SIDELITES
 PART OR ASSEMBLY:
 GENERAL NOTES &
 TYPICAL ELEVATIONS

NO.	DATE	REVISIONS	BY

 RW BUILDING
 CONSULTANTS, INC.
 813.659.9197

DATE: 7/15/02

SCALE: N.T.S.

DWG. BY: WLN

CHK. BY: RW

DRAWING NO.:

TT-103-OC

SHEET 1 OF 4

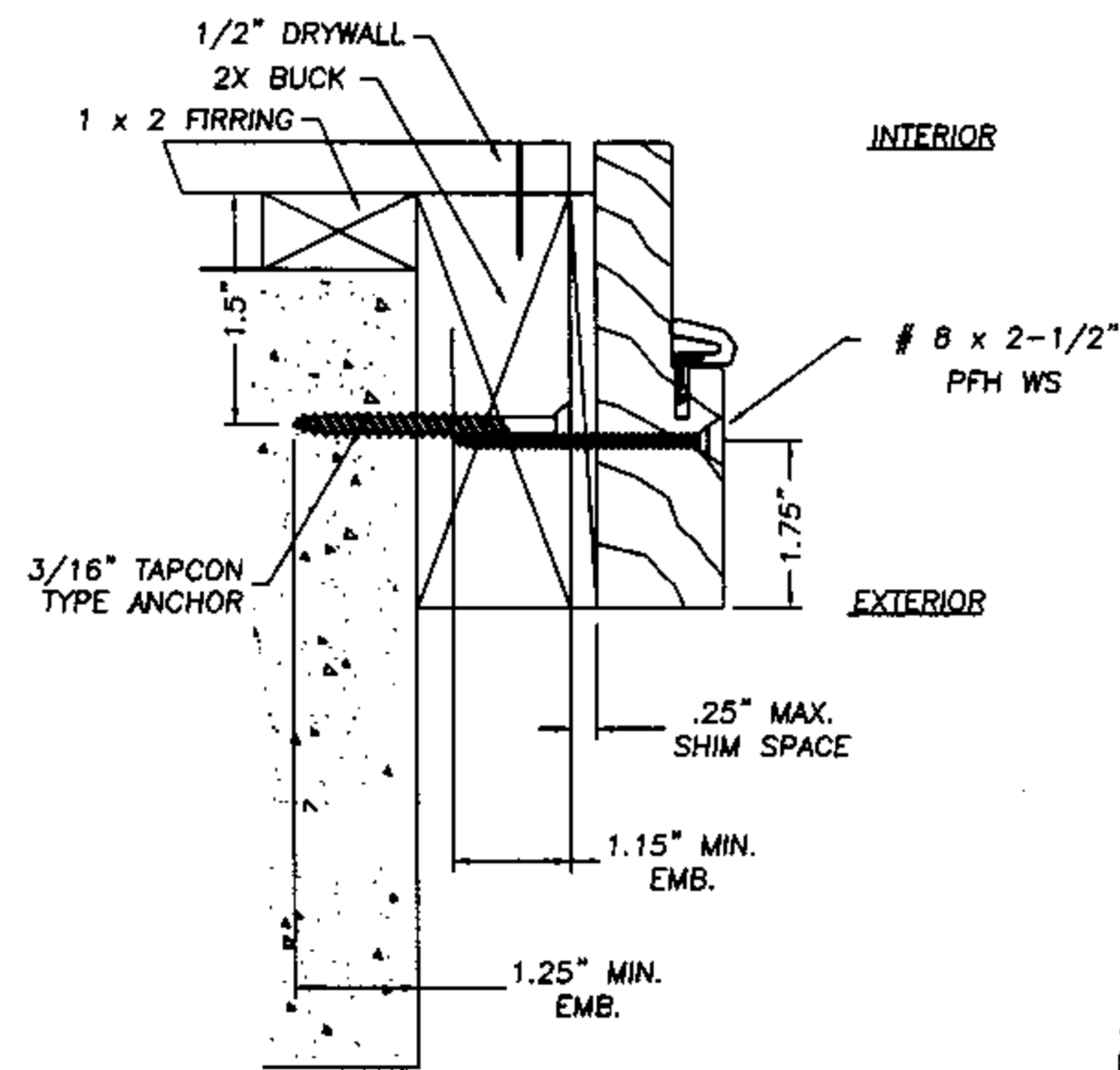
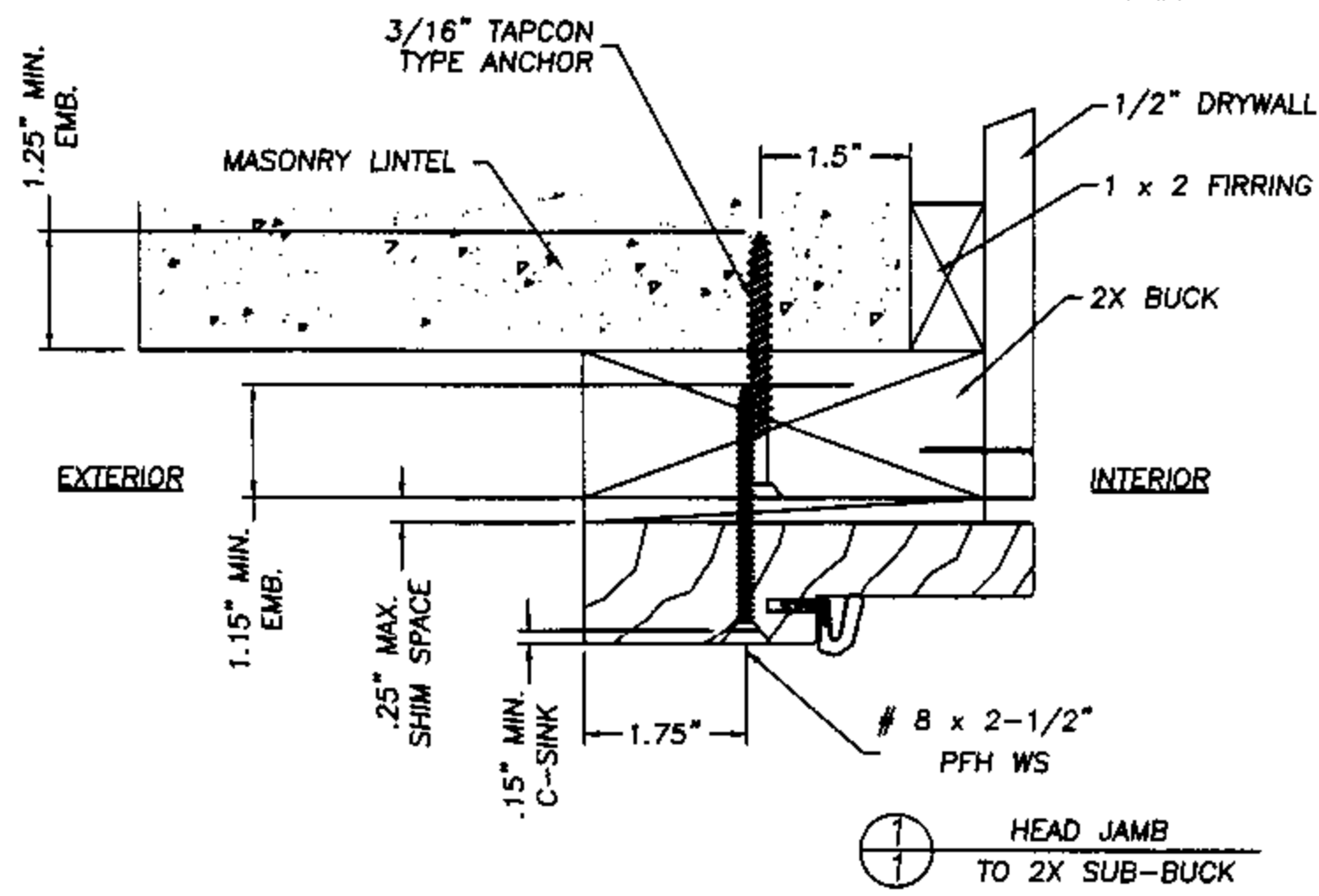

① VERTICAL SIDE JAMB TO 2X SUB-BUCK

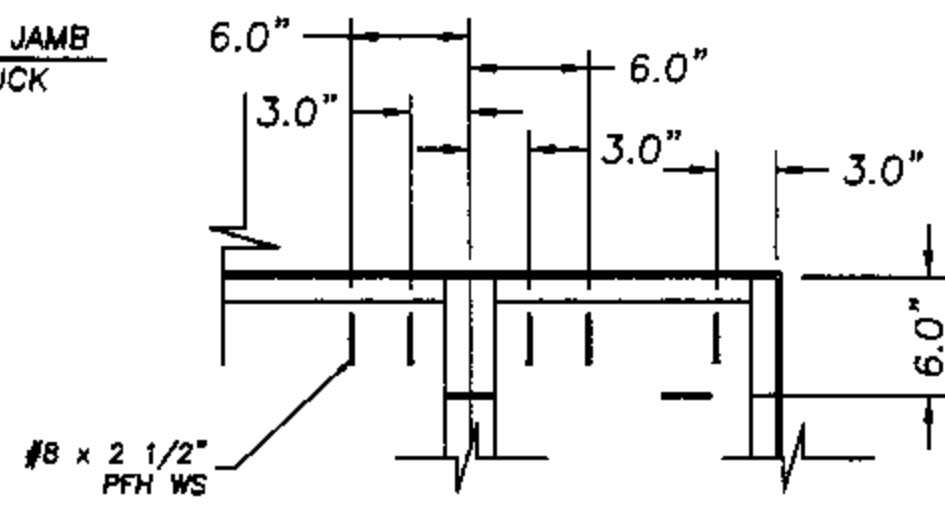

ANCHORING OF SIDELITE TO 2X BUCK

NOTE:
A minimum clearance of 2.0" for all anchoring screws to mortar joints must be maintained.

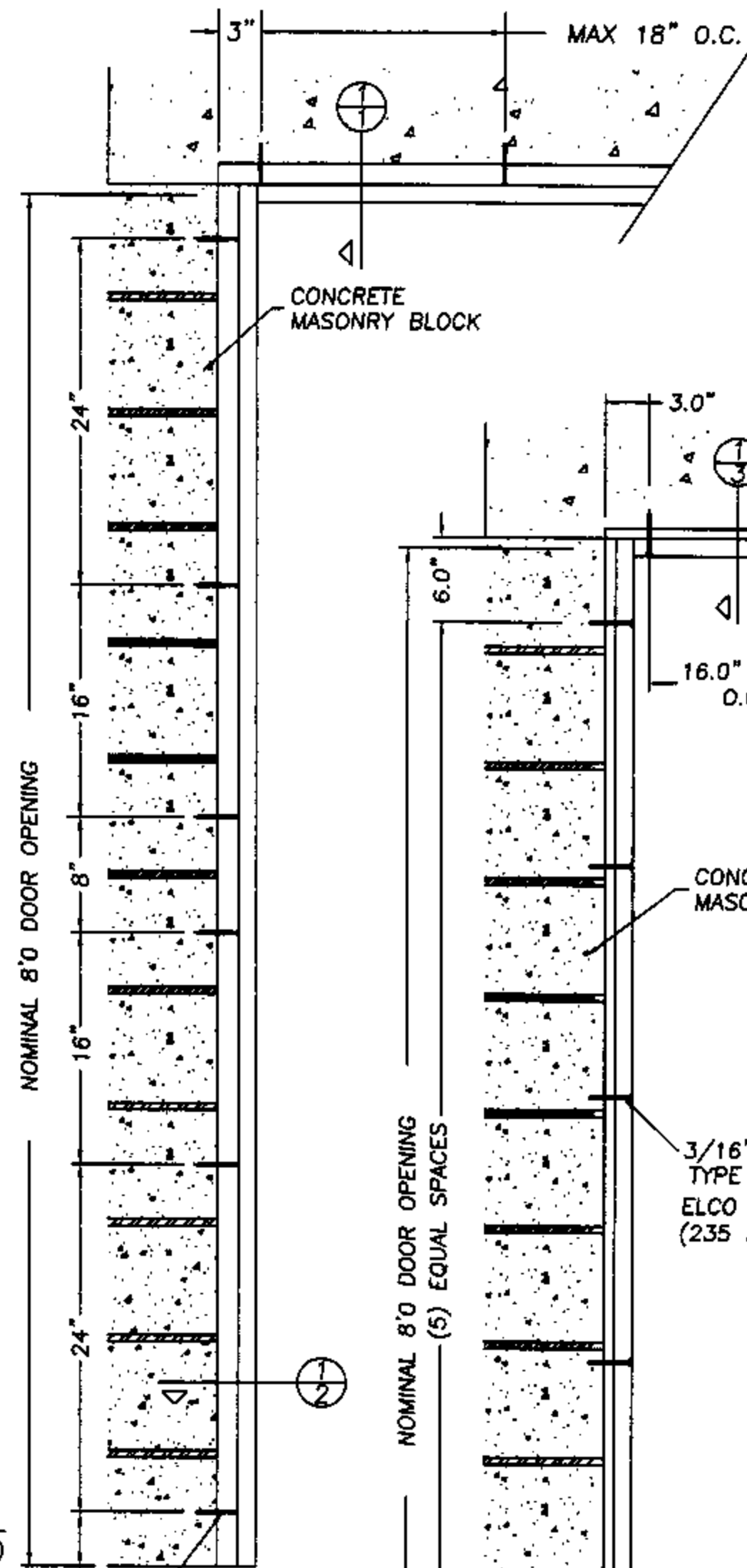

3/16" TAPCON TYPE ANCHOR
2 X INSTALLATION

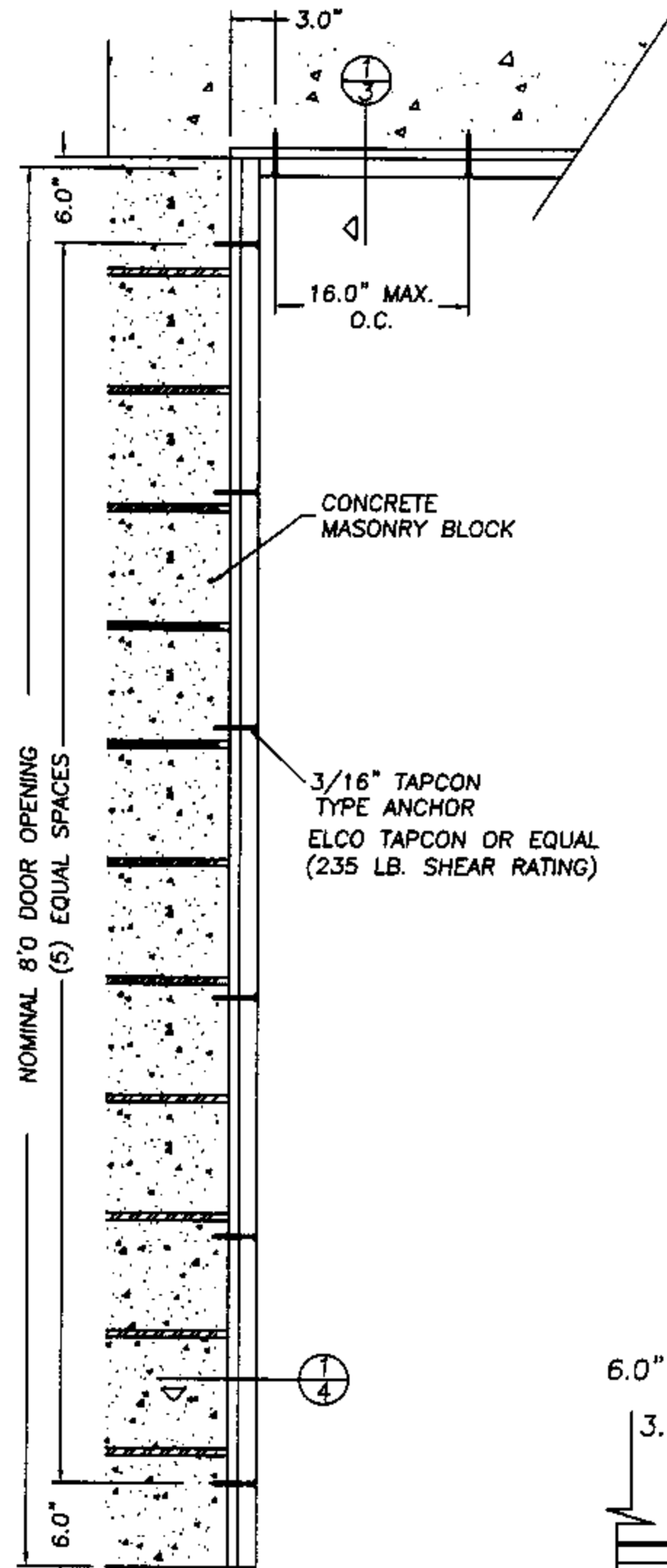

1 X INSTALLATION

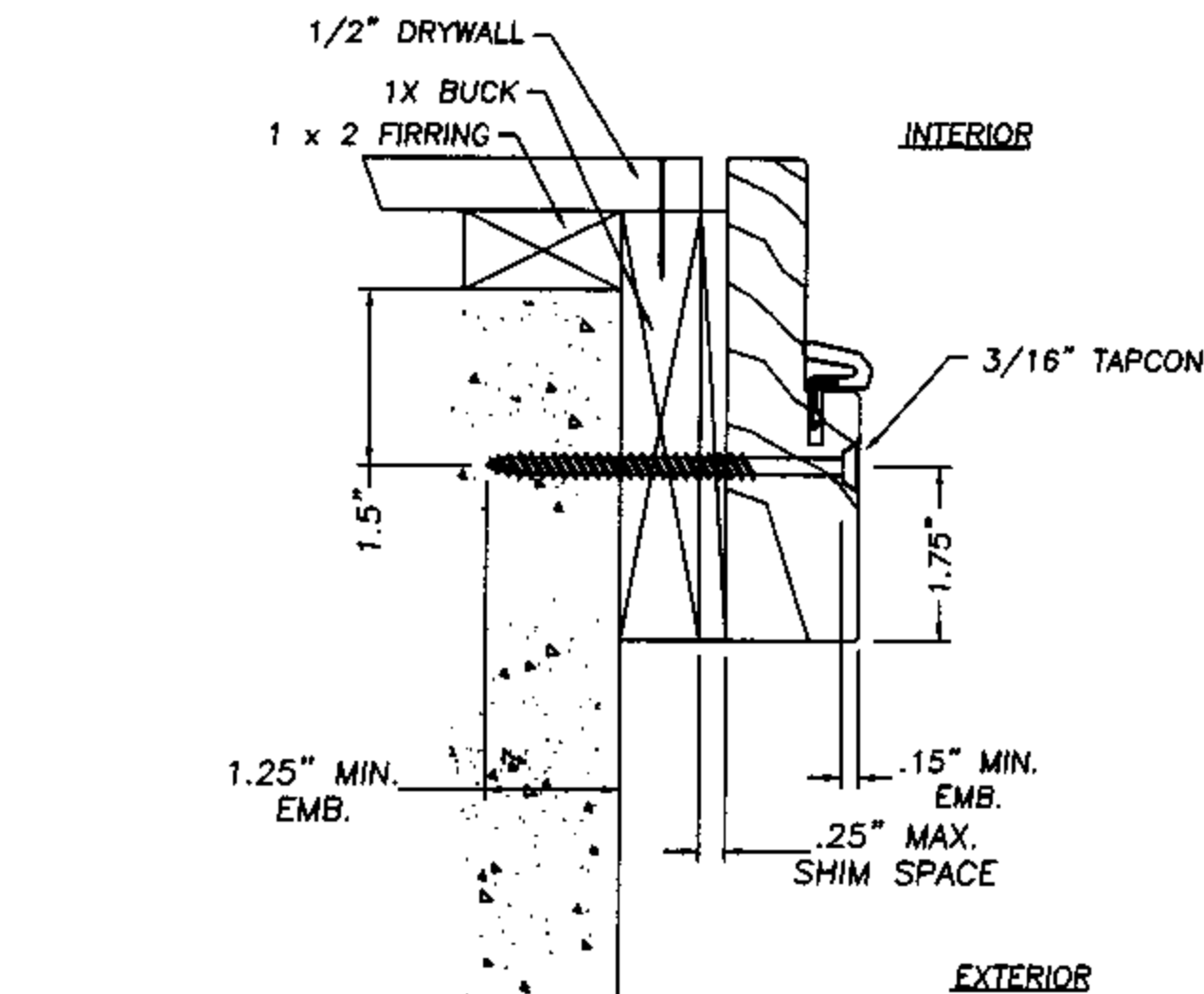
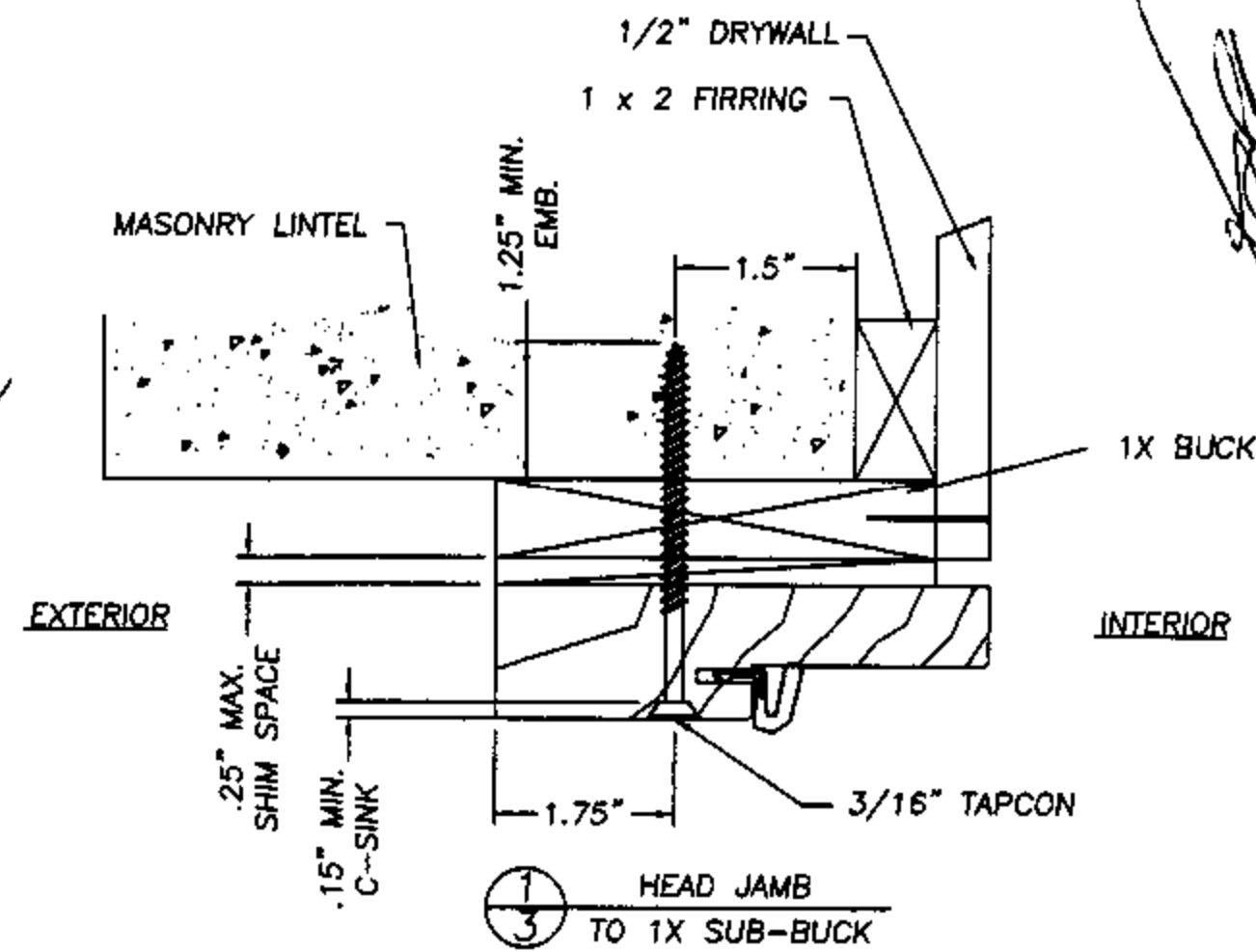

④ VERTICAL SIDE JAMB TO 1X SUB-BUCK

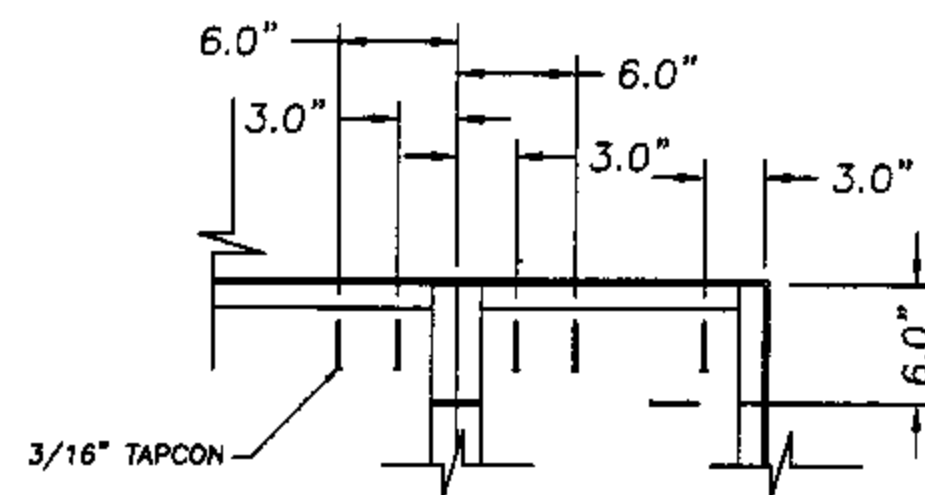

ANCHORING OF SIDELITE THROUGH 1X BUCK

AUGUST 12, 2002
Lyndon F. Schmidt
Florida P. E. No. 43409
19506 French Lace Drive
Lutz, FL 33558

THERMA-TRU CORPORATION
1687 WOODLANDS DRIVE
MAUMEE, OHIO
PH. (800) 537-8827

ANCHOR CROSS SECTIONS
MASONRY 8'0
IN-SWING WOOD FRAME

RW BUILDING
CONSULTANTS, INC.
813.659.9197

DATE: 7/15/02
SCALE: NTS
DWG. BY: WLN
CHK. BY: RW
DRAWING NO.: TT-103-OC
SHEET 2 OF 4

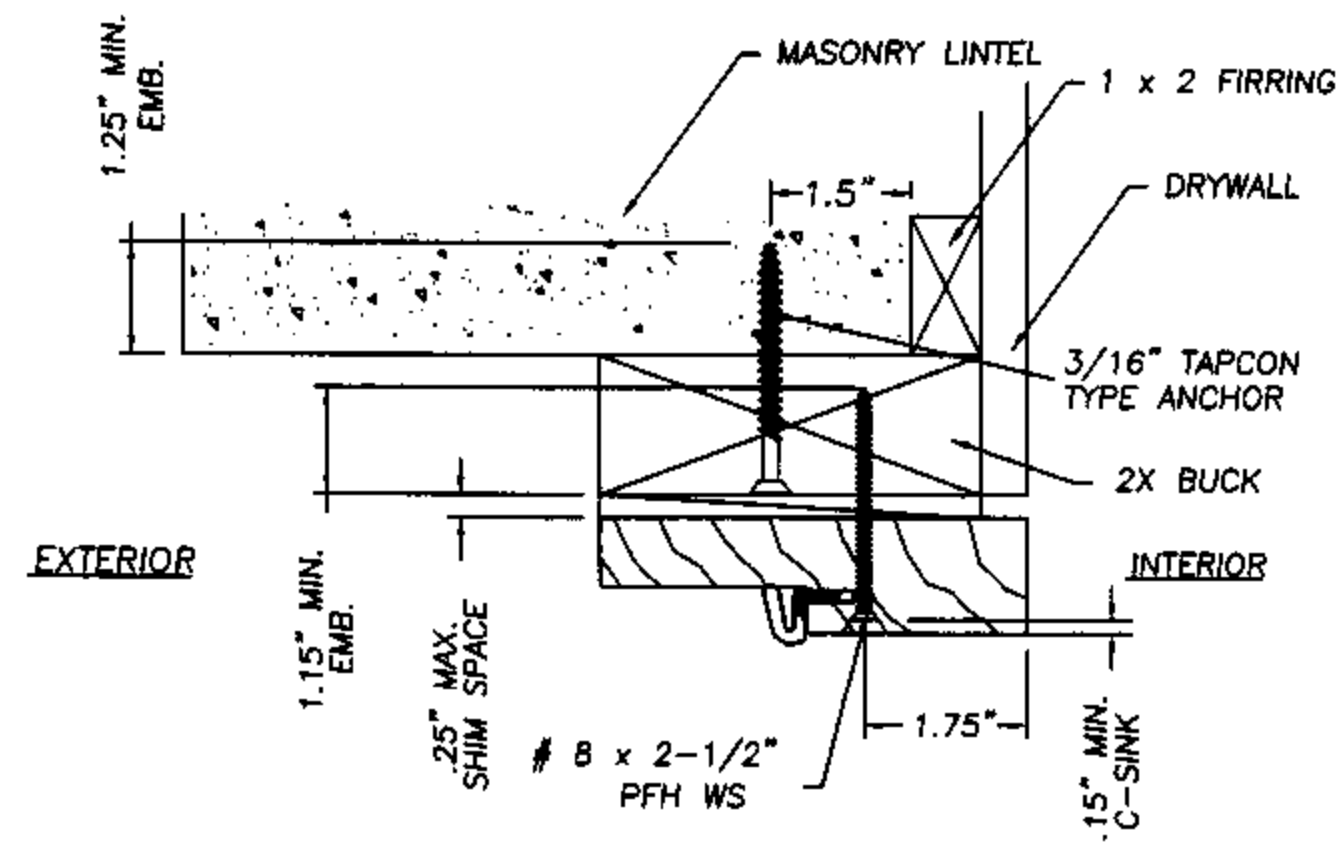

HEAD JAMB TO 2X SUB-BUCK

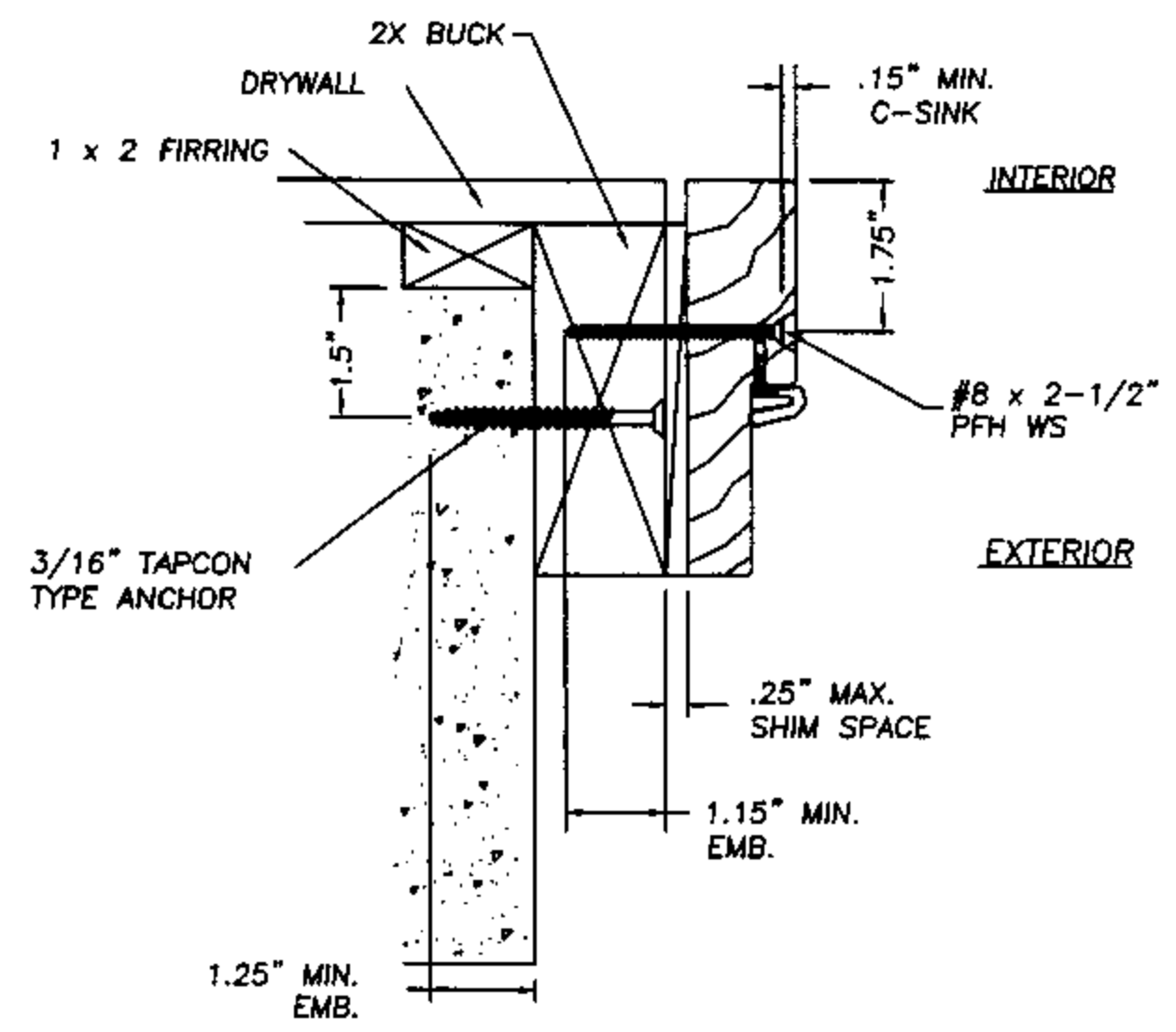

VERTICAL SIDE JAMB TO 2X SUB-BUCK

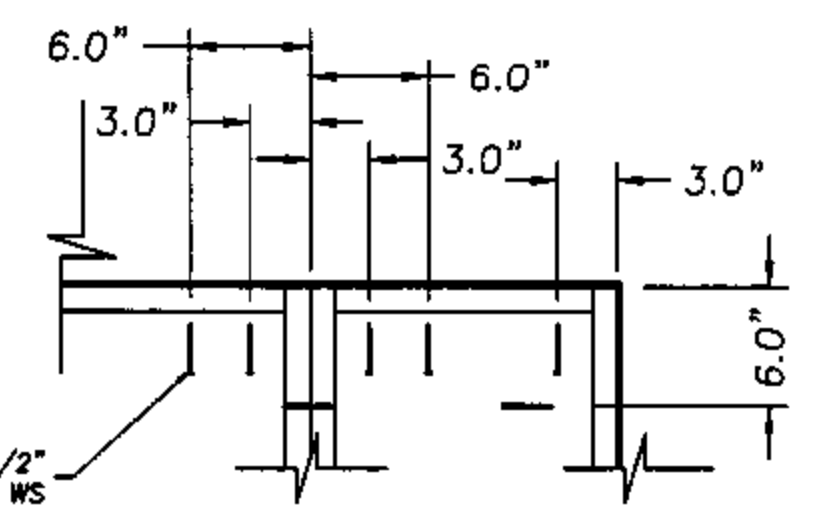

ANCHORING OF SIDELITE TO 2X BUCK

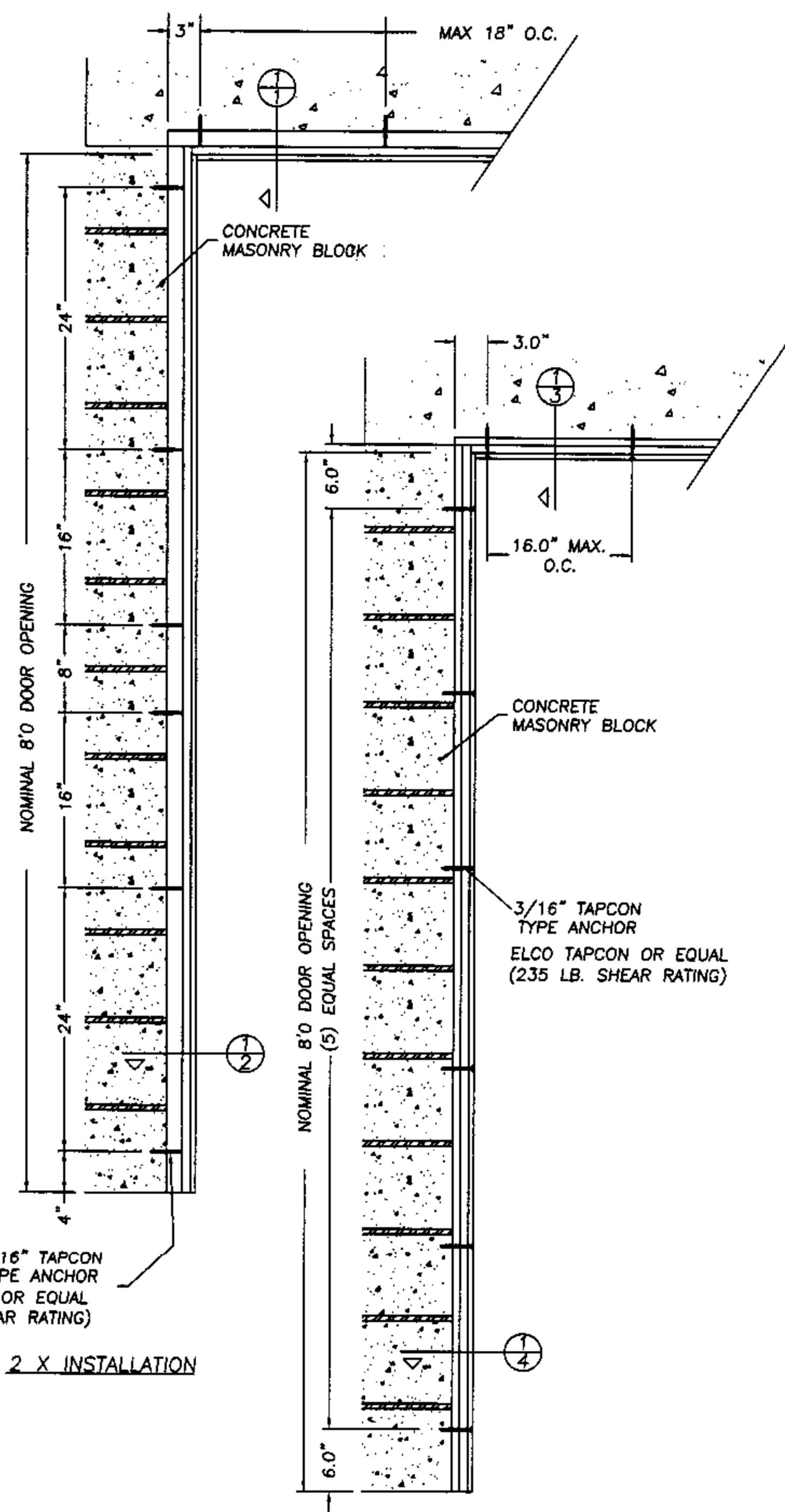

2 X INSTALLATION

1 X INSTALLATION

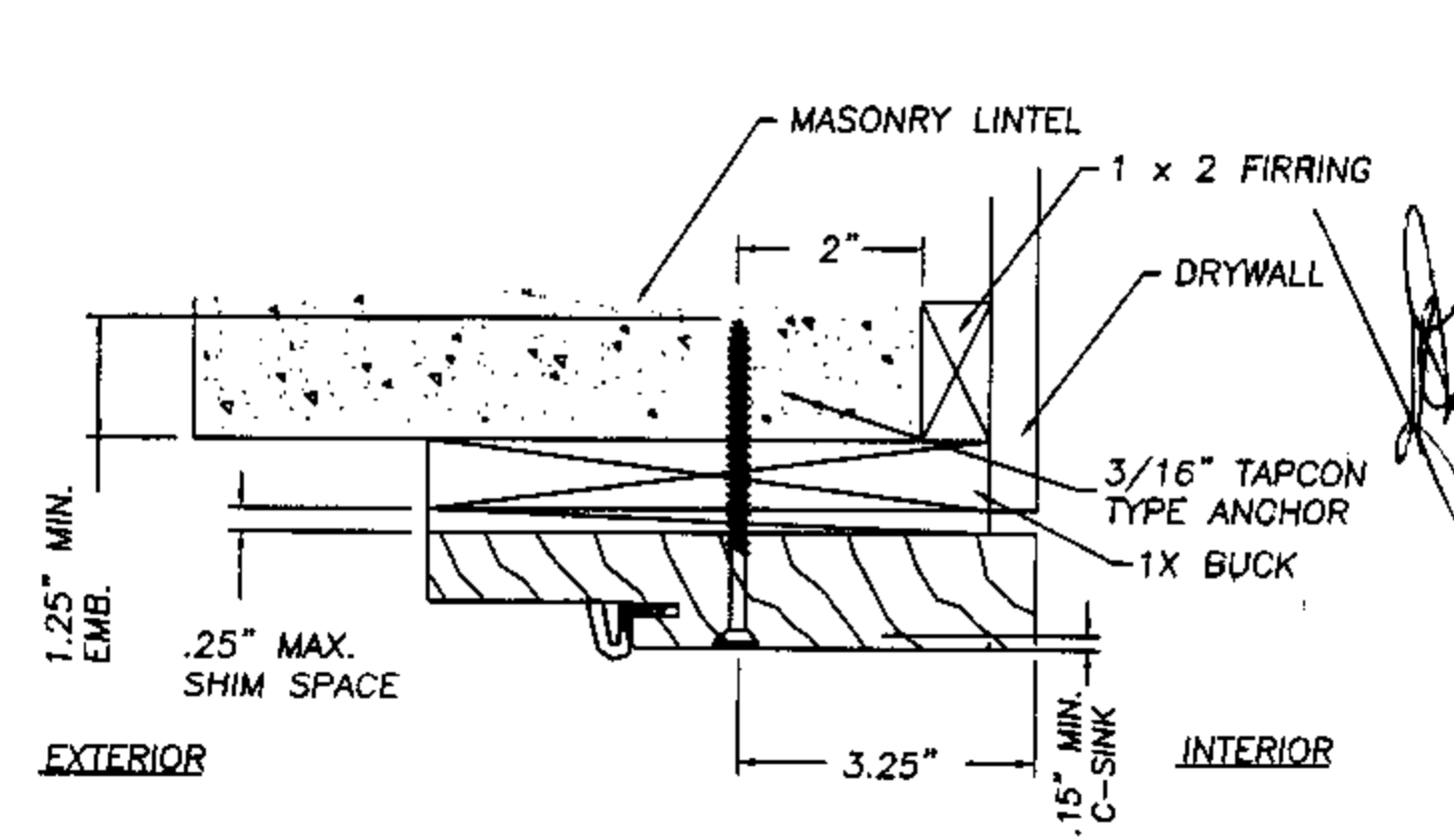

HEAD JAMB TO 1X SUB-BUCK

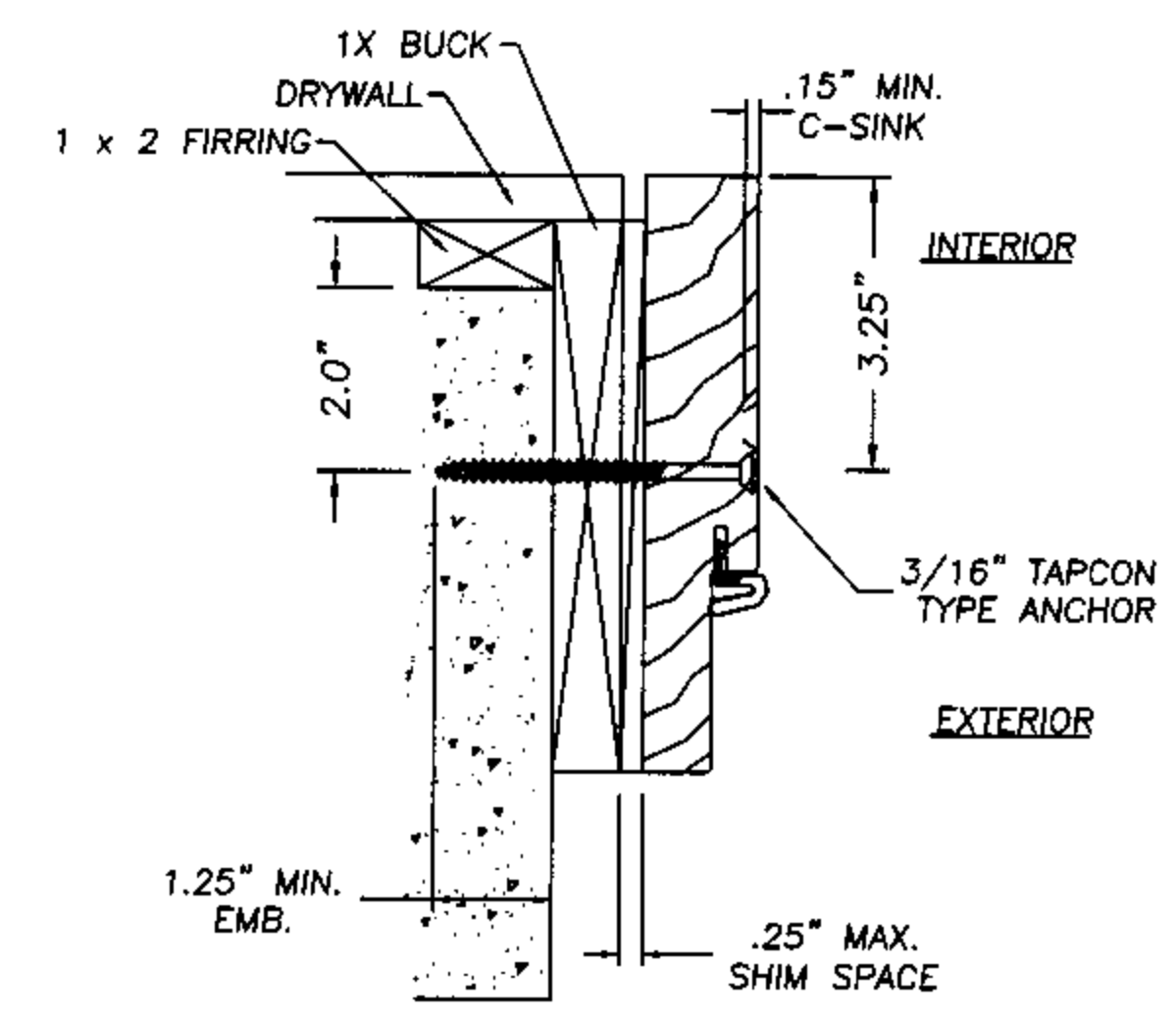

VERTICAL SIDE JAMB TO 1X SUB-BUCK

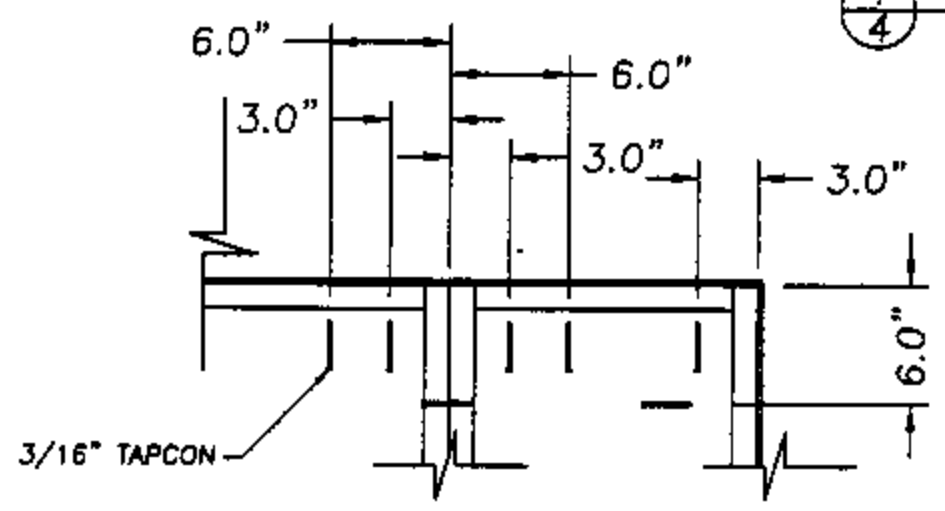

ANCHORING OF SIDELITE THROUGH 1X BUCK

- NOTE:
1. When using a 1X sub-buck a 6-9/16" jamb is required to allow for min. edge spacing for Tapcon type anchors.
 2. A minimum clearance of 2.0" for all anchoring screws to mortar joints must be maintained.

AUGUST 12, 2002
 Lyndon F. Schmidt
 Florida P. E. No. 43409
 19506 French Lace Drive
 Lutz, FL 33558

THERMA-TRU CORPORATION
 1687 WOODLANDS DRIVE
 MAUMEE, OHIO
 PH. (800) 537-8827

ANCHOR CROSS SECTIONS
 MASONRY 8'0
 OUT-SWING WOOD FRAME

RW BUILDING
 CONSULTANTS, INC.
 813.659.9197

DATE: 7/15/02
 SCALE: NTS
 DWG. BY: WLN
 CHK. BY: RW
 DRAWING NO.: TT-103-OC
 SHEET 3 OF 4

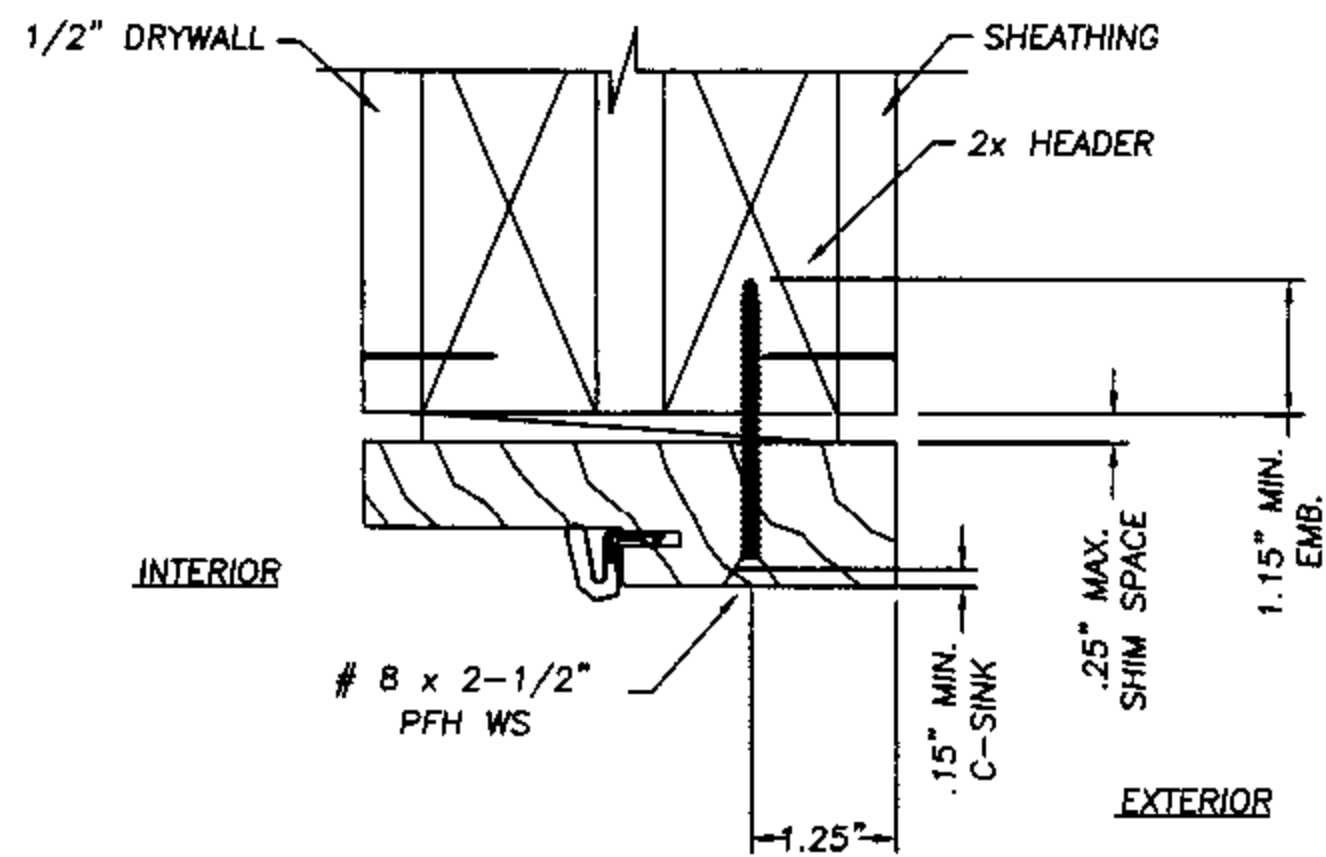

① HEAD JAMB

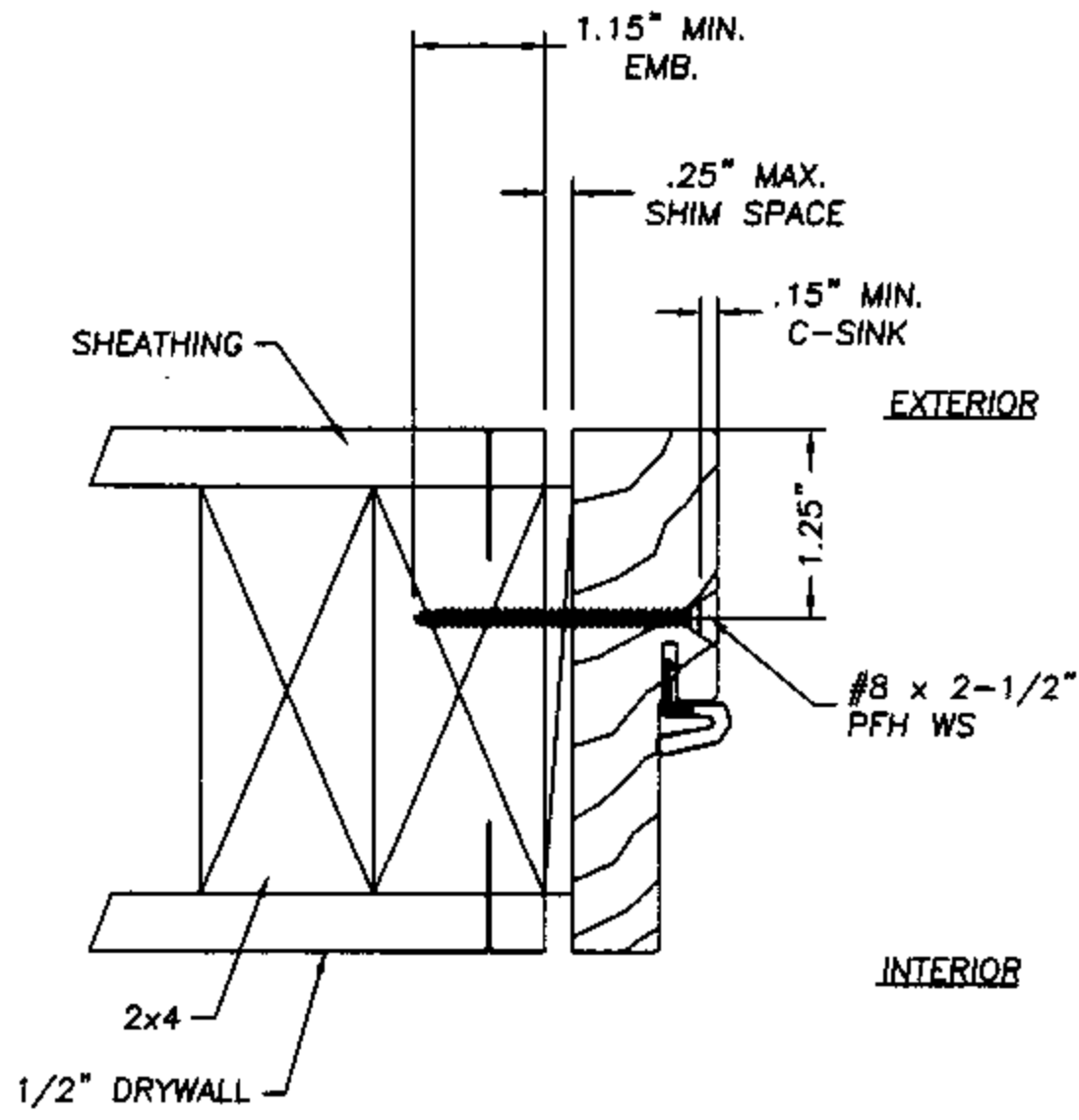

② VERTICAL SIDE JAMB

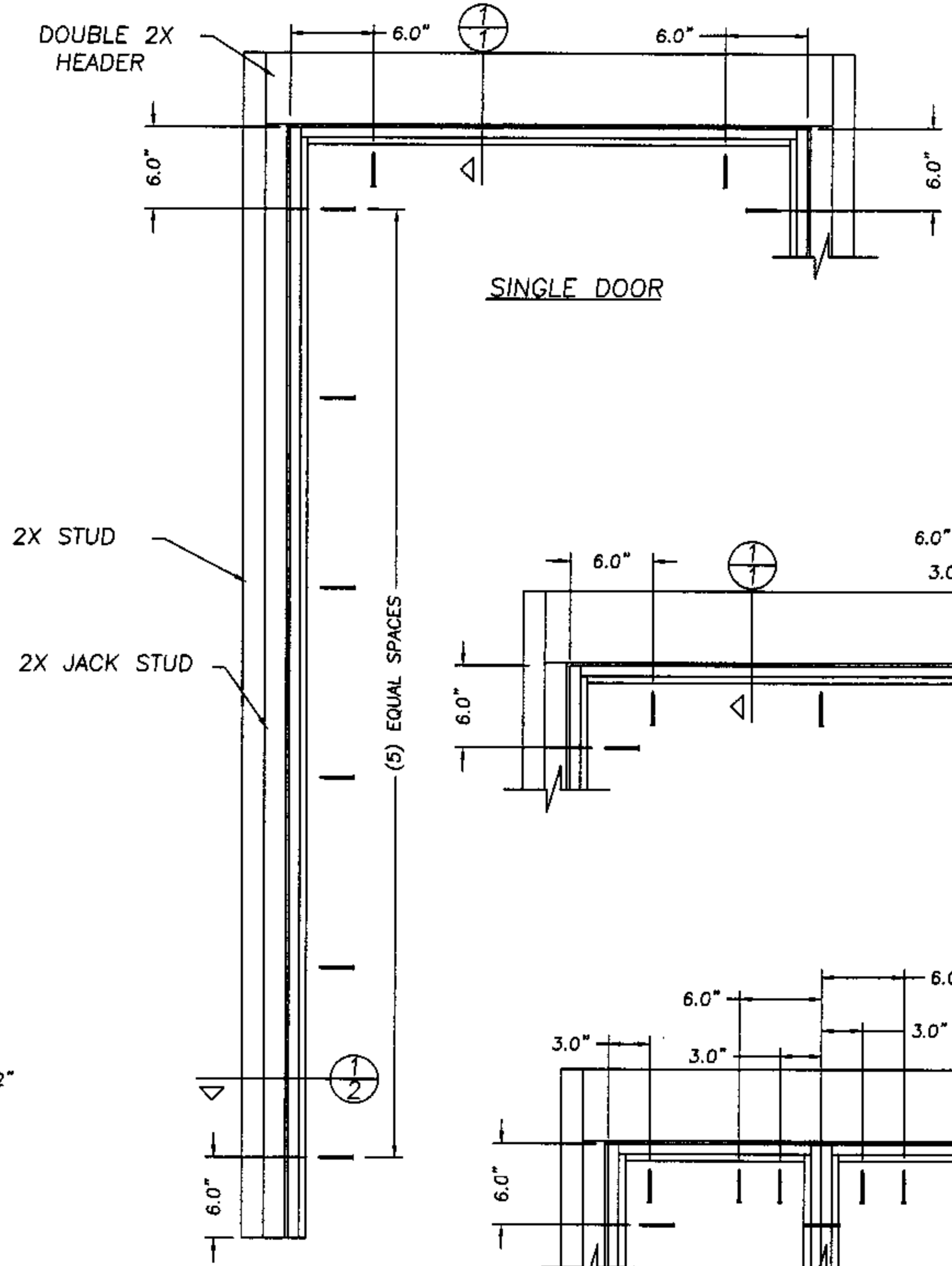

SINGLE DOOR

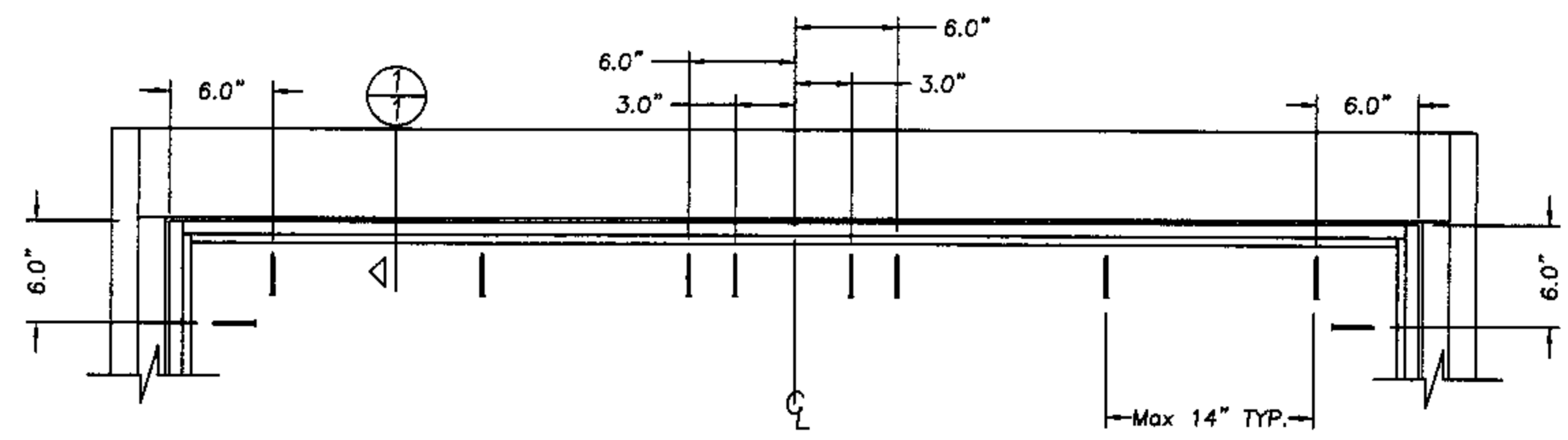

DOUBLE DOOR

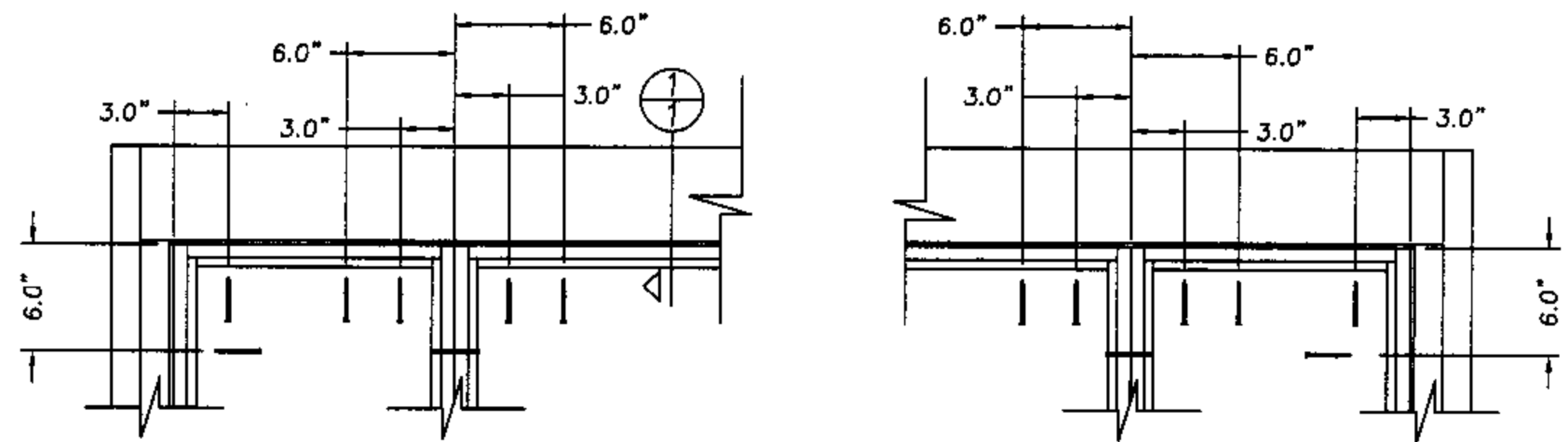

SINGLE OR DOUBLE DOOR WITH SIDELITES

AUGUST 12, 2002
 Lyndon F. Schmidt
 Florida P. E. No. 43409
 19506 French Lace Drive
 Lutz, FL 33558

THERMA-TRU CORPORATION
 1687 WOODLANDS DRIVE
 MAUMEE, OHIO
 PH. (800) 537-8827

ANCHOR CROSS SECTIONS
 WOOD OR STEEL STUD
 IN-SWING / OUT-SWING
 WOOD FRAME

RW BUILDING
 CONSULTANTS, INC.
 813.659.9197

DATE: 7/15/02
 SCALE: NTS
 DWG. BY: WLN
 CHK. BY: RW
 DRAWING NO.: TT-103-OC
 SHEET 4 OF 4