

# FIBER CLASSIC / SMOOTH STAR®

GLAZED INSULATED FIBERGLASS DOOR  
OUT-SWING / IN-SWING 8-0 UNITS W/ & W/OUT SIDELITES

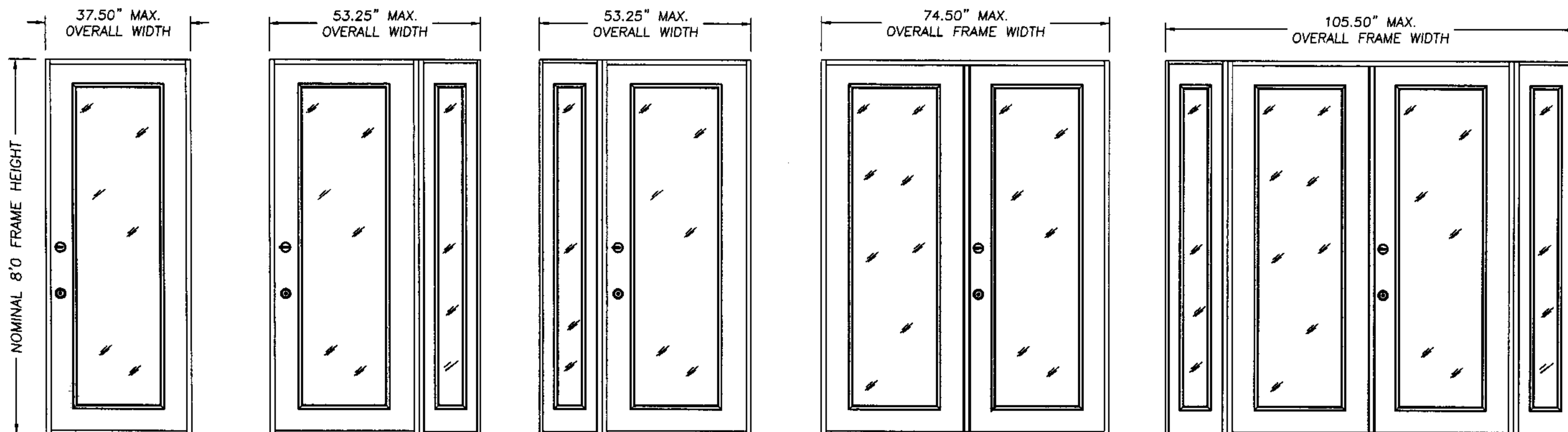

X

DESIGN PRESSURE RATING
OUT-SWING / IN-SWING POS. 47.0 NEG. 47.0

X O

DESIGN PRESSURE RATING
OUT-SWING / IN-SWING POS. 47.0 NEG. 47.0

O X

DESIGN PRESSURE RATING
OUT-SWING / IN-SWING POS. 47.0 NEG. 47.0

X X

ASTRAGAL TYPE	DESIGN PRESSURE RATING
Coastal Alum. Astragal	OUT-SWING / IN-SWING POS. 47.0 NEG. 47.0
* Standard Alum. Astragal	OUT-SWING / IN-SWING POS. 40.0 NEG. 40.0

O X X O

ASTRAGAL TYPE	DESIGN PRESSURE RATING
Coastal Alum. Astragal	OUT-SWING / IN-SWING POS. 47.0 NEG. 47.0
* Standard Alum. Astragal	OUT-SWING / IN-SWING POS. 40.0 NEG. 40.0

GENERAL NOTES

1. THIS PRODUCT IS DESIGNED TO COMPLY WITH THE FLORIDA BUILDING CODE.
2. PRODUCT ANCHORS SHALL BE AS LISTED AND SPACED AS SHOWN ON DETAILS.
3. THE UNITS REQUIRE WINDBORNE DEBRIS EXTERNAL PROTECTION AS DESCRIBED IN SECTION 1626.1 OF THE FLORIDA BUILDING CODE WHEN USED IN WINDBORNE DEBRIS AREAS.
4. FOR INSWING MASONRY ANCHORING SEE SHEET 2 OF 4.
5. FOR OUTSWING MASONRY ANCHORING SEE SHEET 3 OF 4.
6. FOR INSWING/OUTSWING WOOD STUD ANCHORING SEE SHEET 4 OF 4.

PRODUCT DESCRIPTION

1. THE DOOR FACE SHEETS ARE FIBER CLASSIC (0.110") SMOOTH STAR (0.070")
2. THE STILES AND RAILS ARE WOOD CONSTRUCTION.
3. THE INTERIOR DOOR CAVITY IS URETHANE.
4. THE SIDELITE GLAZING IS 0.5" INSULATED TEMPERED GLASS BY THERMA-TRU.
5. THE WOOD JAMBS ARE A MIN. 4-9/16".
6. THE THRESHOLD IS AN ALUMINUM BUMP FACE TYPE (OUTSWING) OR AN ALUMINUM SADDLE TYPE (INSWING).
- \*7. THE STANDARD ALUMINUM ASTRAGAL UTILIZES 18.875" LONG x 0.312" DIA. STEEL ROD WITH A 17.375" LONG ALUMINUM SLIDE ROD REINFORCEMENT BAR AT THE TOP AND A 7.5" LONG X 0.312" DIA. STEEL ROD WITH A 6.0" LONG ALUMINUM SLIDE REINFORCEMENT BAR AT THE BOTTOM.
8. ALL LATCHBOLT AND DEADBOLT HARDWARE MUST BE CYLINDRICAL GRADE II WITH A 161 EDGE PREP AND A MINIMUM 1.0" DEADBOLT THROW.

AUGUST 12, 2002  
Lyndon F. Schmidt  
Florida P. E. No. 43409  
19506 French Lace Drive Lutz, FL 33558

THERMA-TRU CORPORATION  
1687 WOODLANDS DRIVE  
MAUMEE, OHIO  
PH. (800) 537-8827

PRODUCT: WOOD EDGE FIBERGLASS DOOR  
GLAZED W/NO SIDELITES  
PART OR ASSEMBLY:  
GENERAL NOTES &  
TYPICAL ELEVATIONS

NO.	DATE	BY	REVISIONS

**RW** BUILDING  
CONSULTANTS, INC.  
813.659.9197

DATE: 7/15/02  
SCALE: N.T.S.  
DWG. BY: WLN  
CHK. BY: RW  
DRAWING NO.: TT-104-OC  
SHEET 1 OF 4

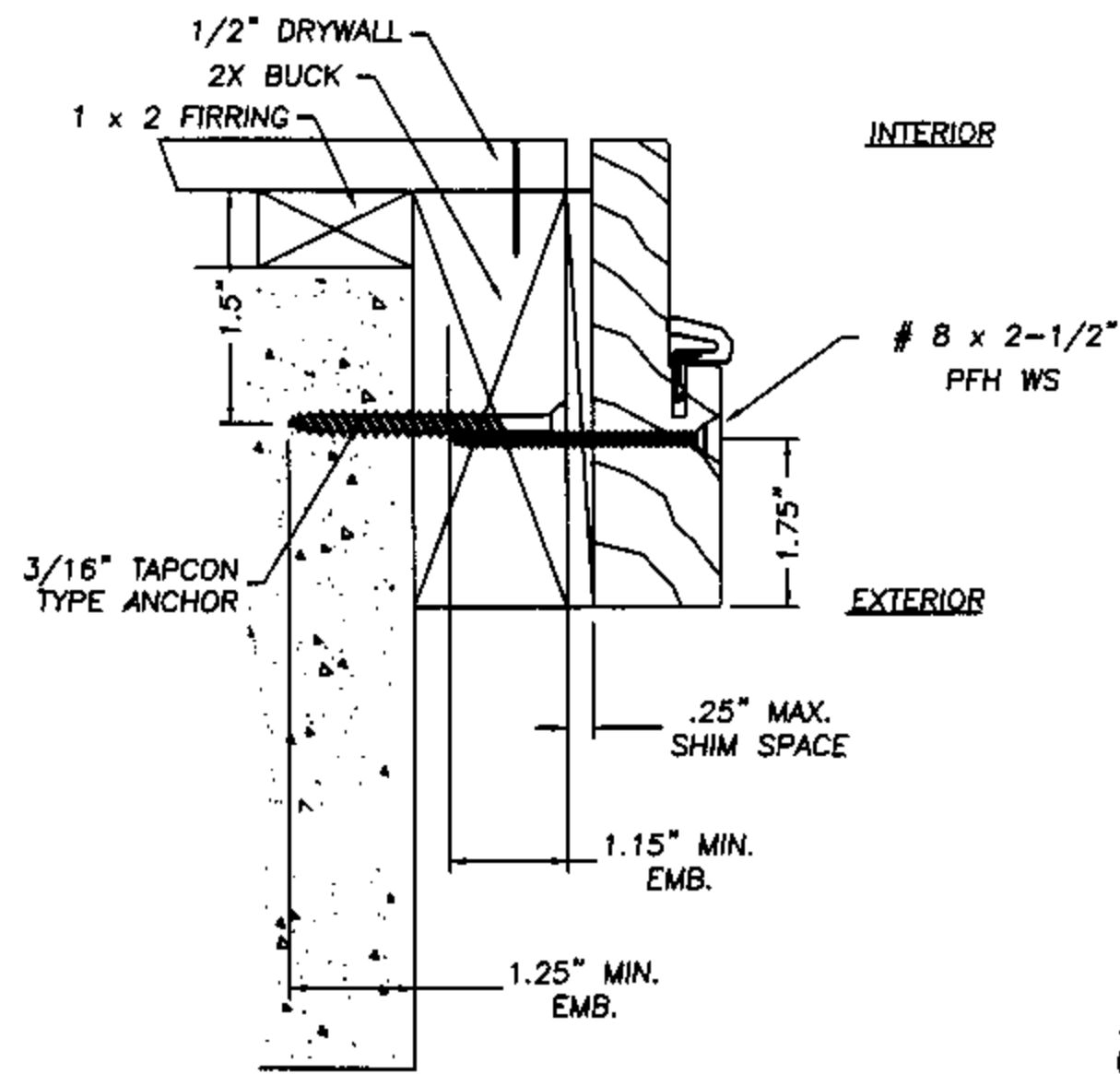
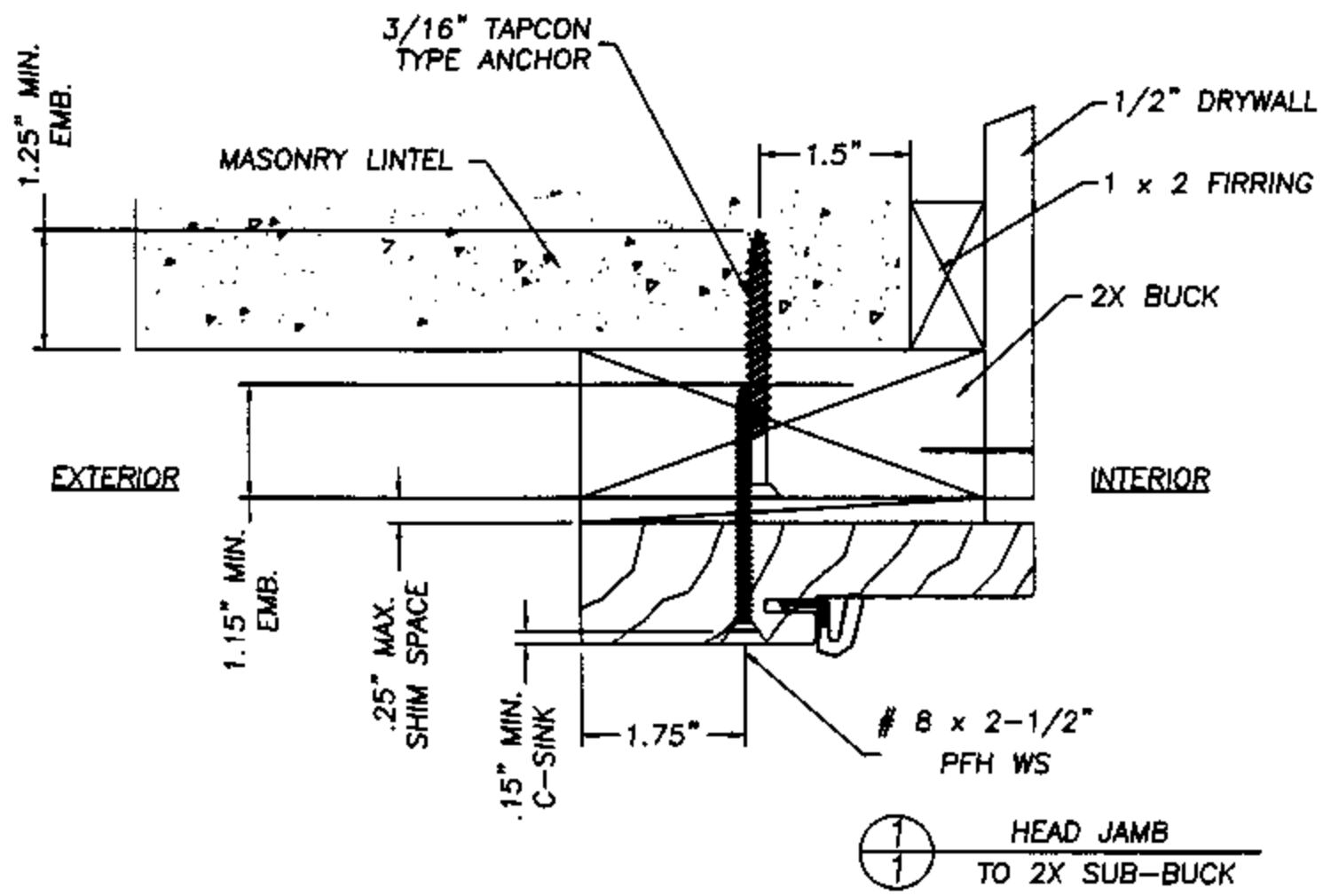

① VERTICAL SIDE JAMB TO 2X SUB-BUCK

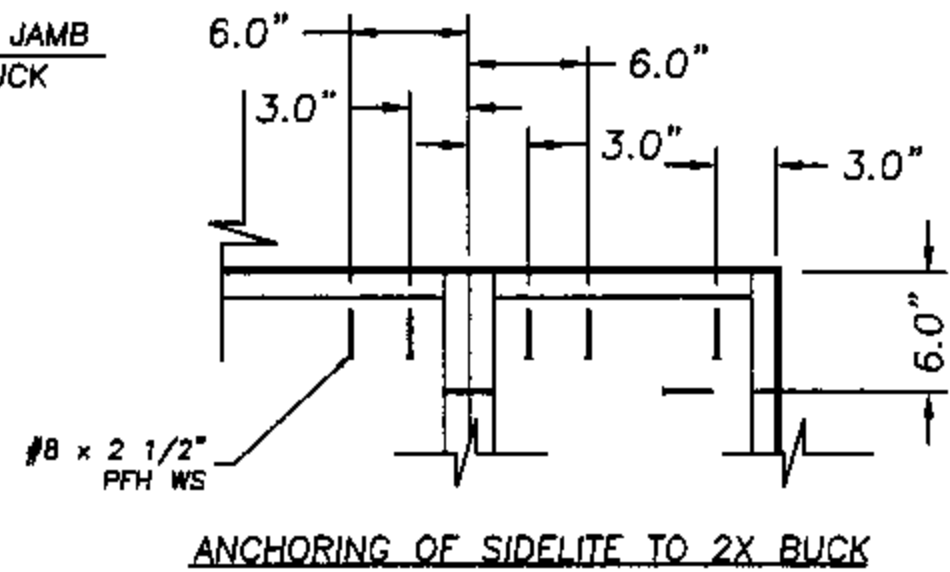

ANCHORING OF SIDELITE TO 2X BUCK

**NOTE:**

A minimum clearance of 2.0" for all anchoring screws to mortar joints must be maintained.

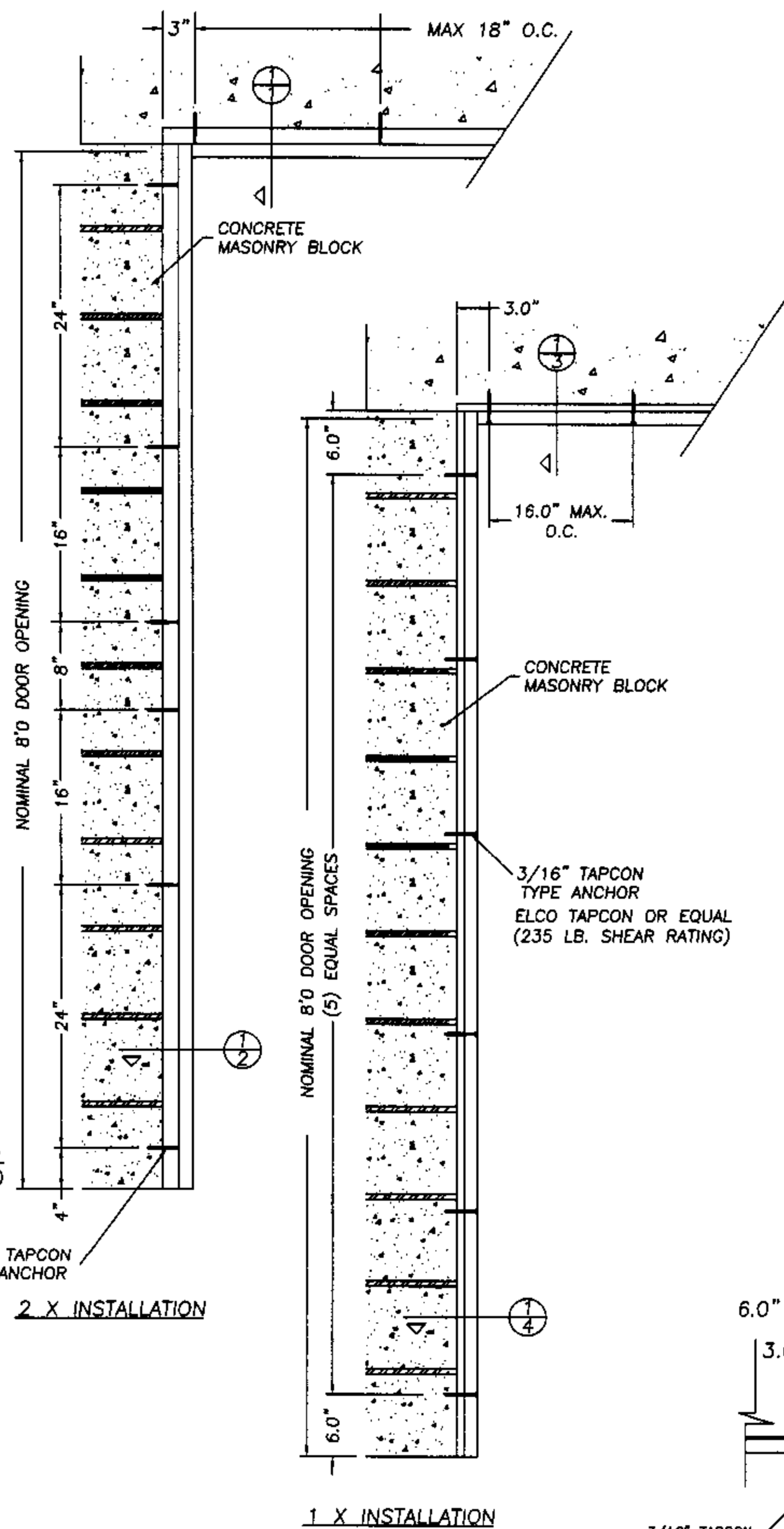

2 X INSTALLATION

1 X INSTALLATION

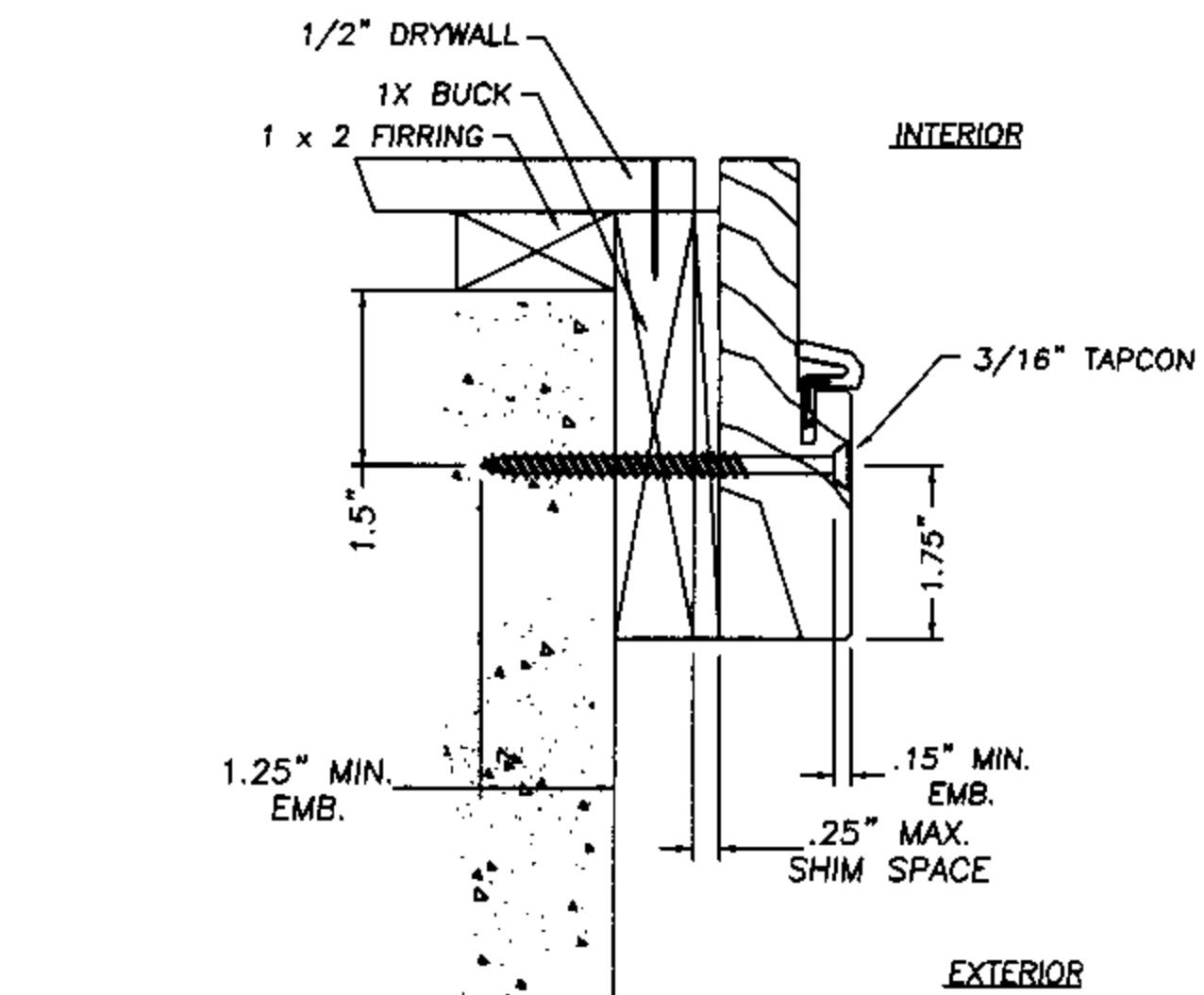
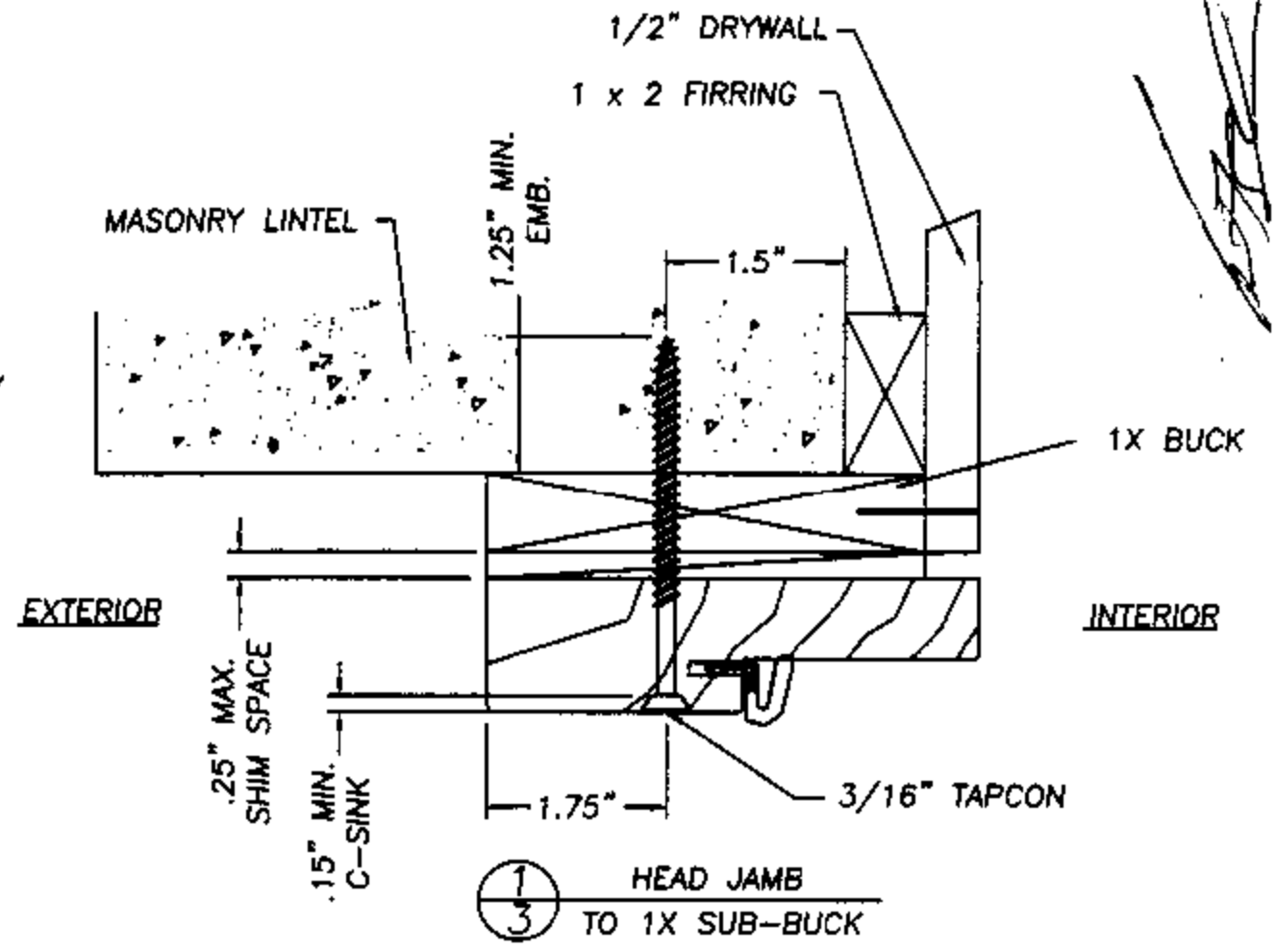

④ VERTICAL SIDE JAMB TO 1X SUB-BUCK

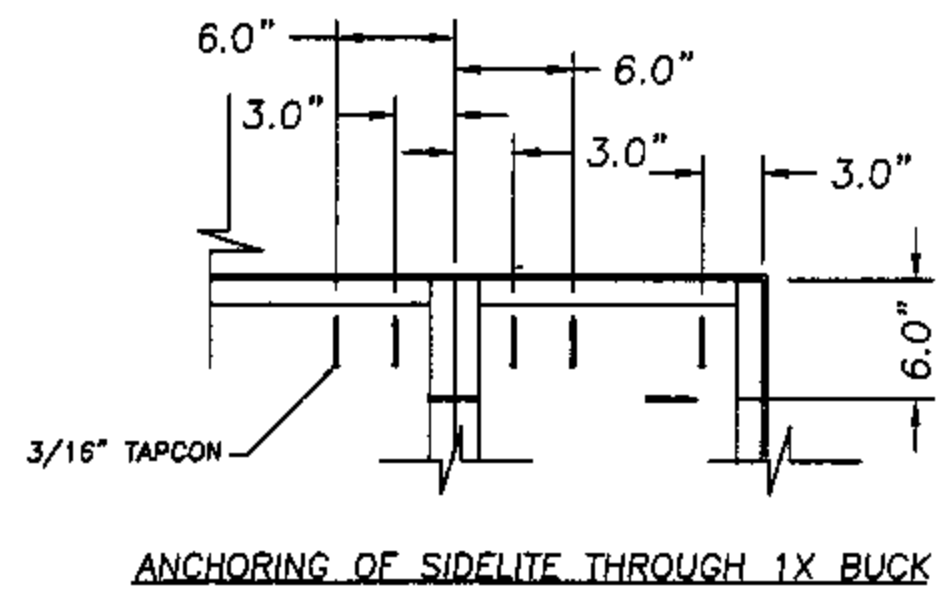

ANCHORING OF SIDELITE THROUGH 1X BUCK

AUGUST 12, 2002  
 Lyndon F. Schmidt  
 Florida P. E. No. 43409  
 19506 French Lace Drive  
 Lutz, FL 33558

**THERMA-TRU CORPORATION**  
 1687 WOODLANDS DRIVE  
 MAUMEE, OHIO  
 PH. (800) 537-8827

ANCHOR CROSS SECTIONS  
 MASONRY 8'0  
 IN-SWING WOOD FRAME

**RW** BUILDING  
 CONSULTANTS, INC.  
 813.659.9197

DATE: 7/15/02  
 SCALE: NTS  
 DWG. BY: WLN  
 CHK. BY: RW  
 DRAWING NO.: TT-104-OC  
 SHEET 2 OF 4

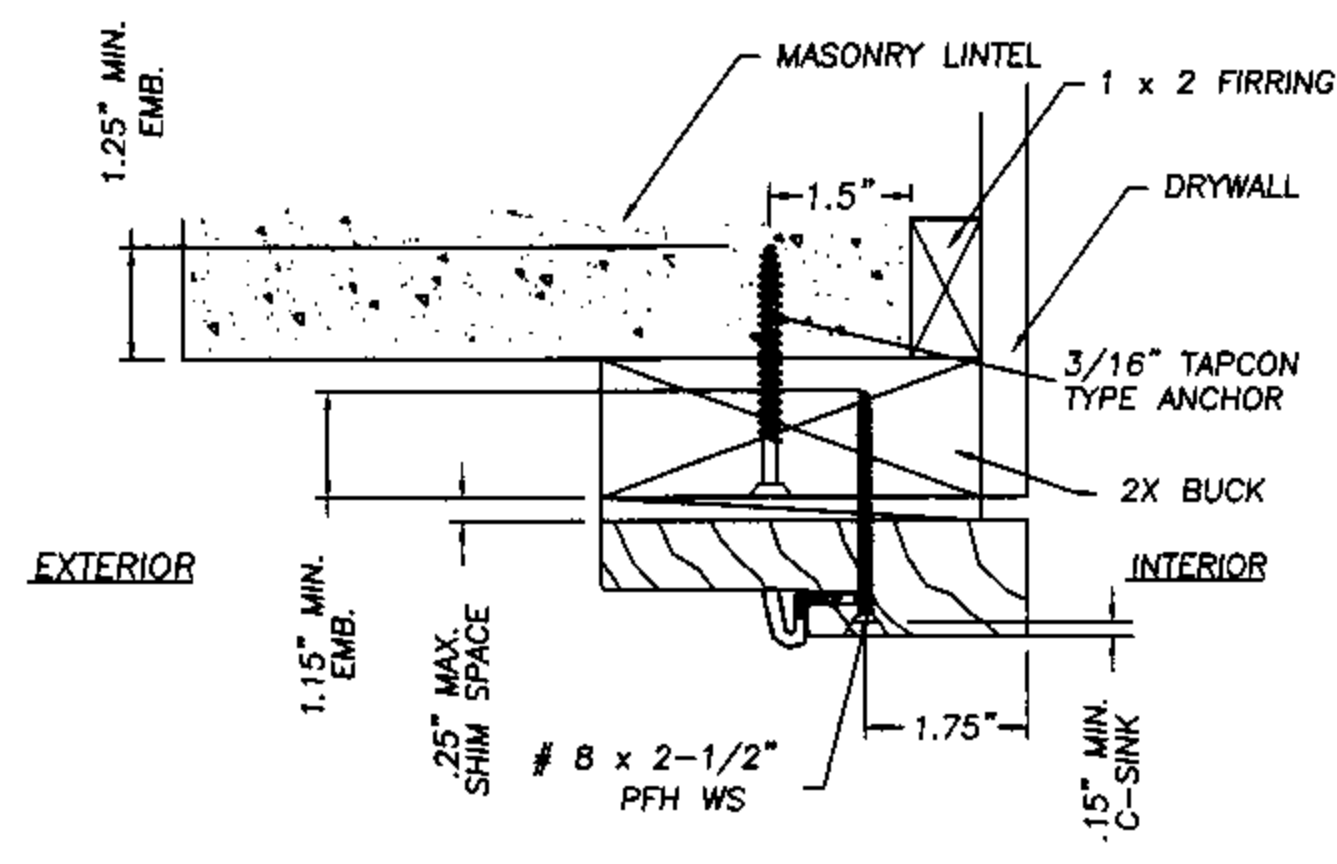

1 HEAD JAMB TO 2X SUB-BUCK

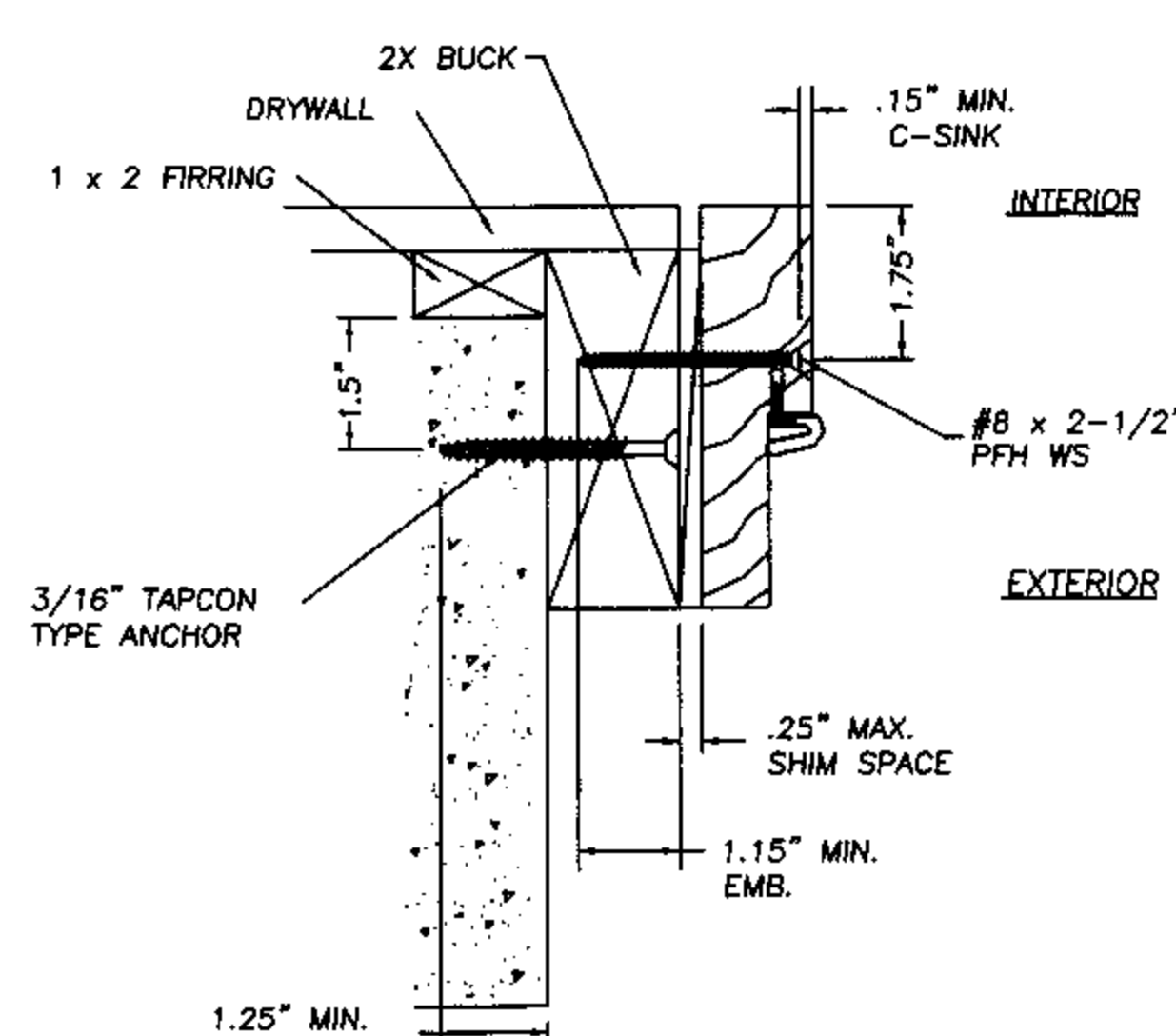

2 VERTICAL SIDE JAMB TO 2X SUB-BUCK

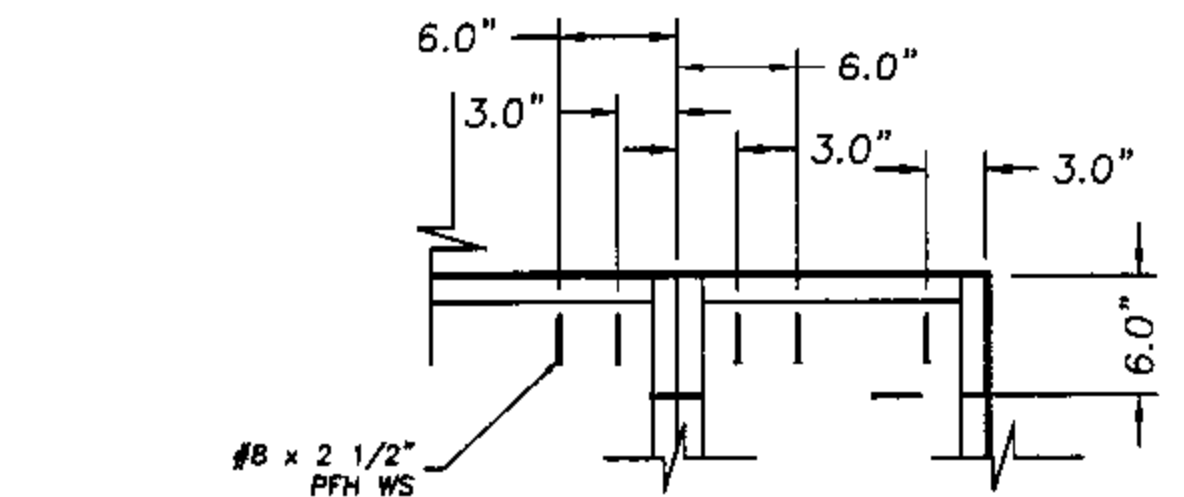

ANCHORING OF SIDELITE TO 2X BUCK

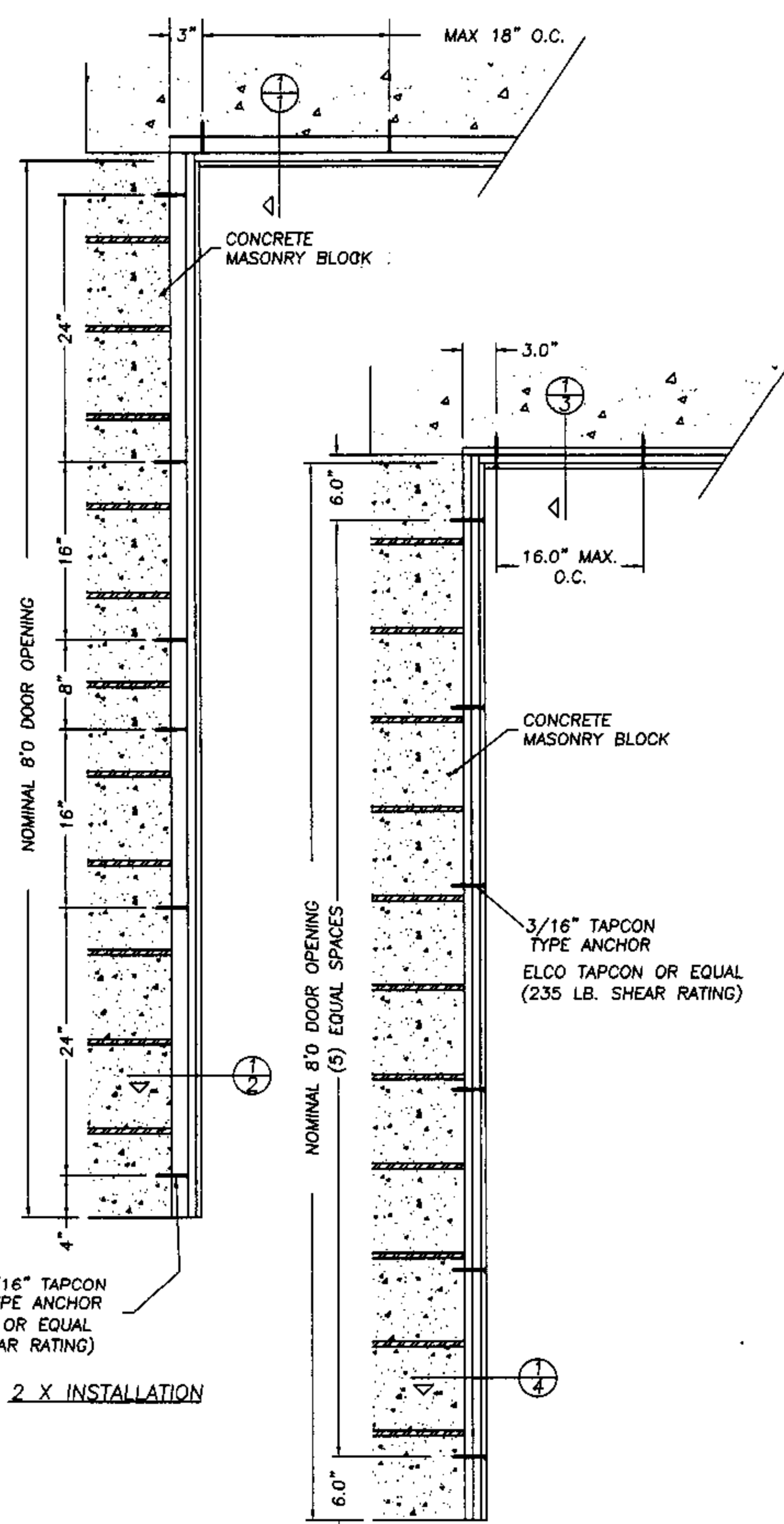

1 X INSTALLATION

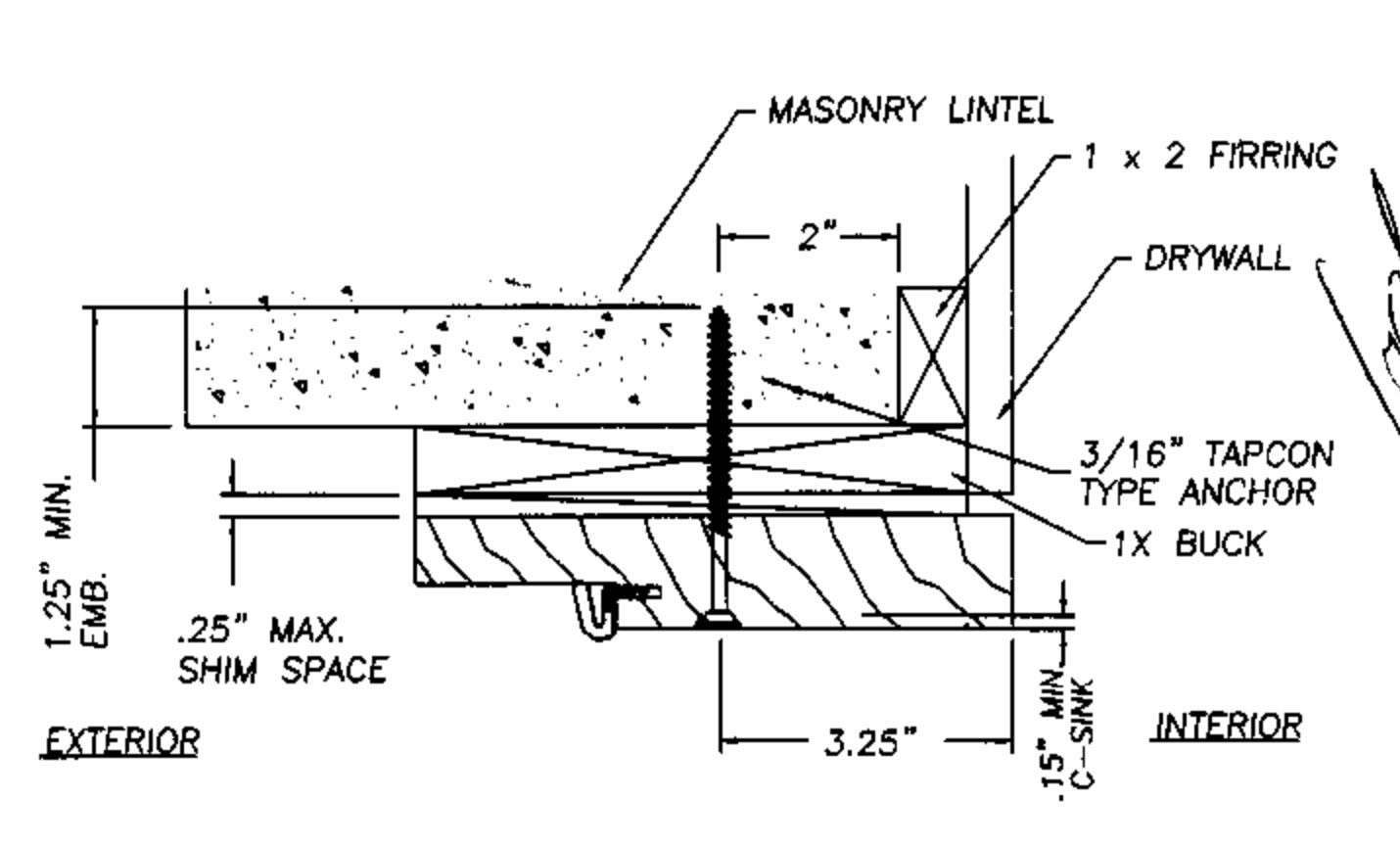

3 HEAD JAMB TO 1X SUB-BUCK

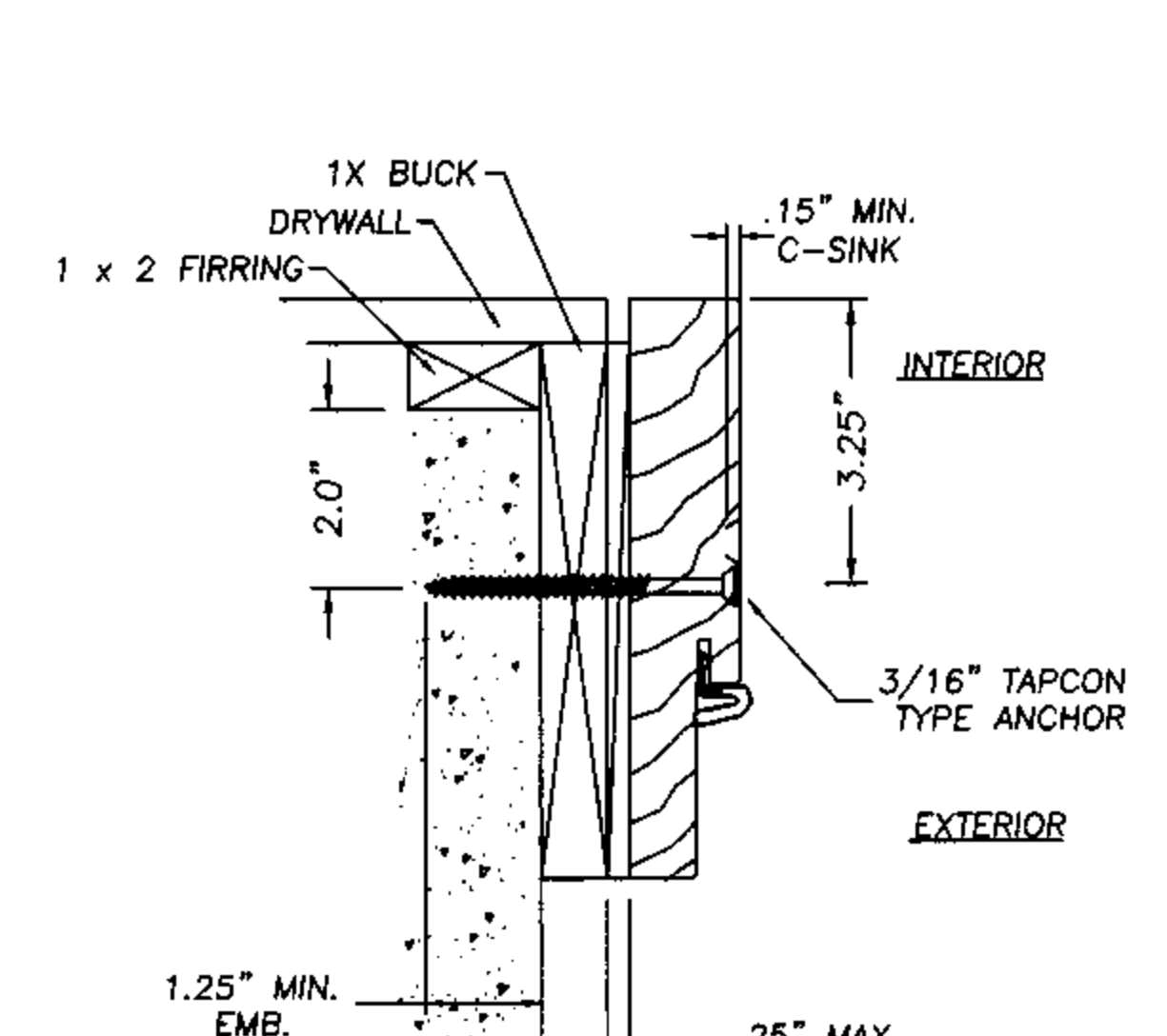

4 VERTICAL SIDE JAMB TO 1X SUB-BUCK

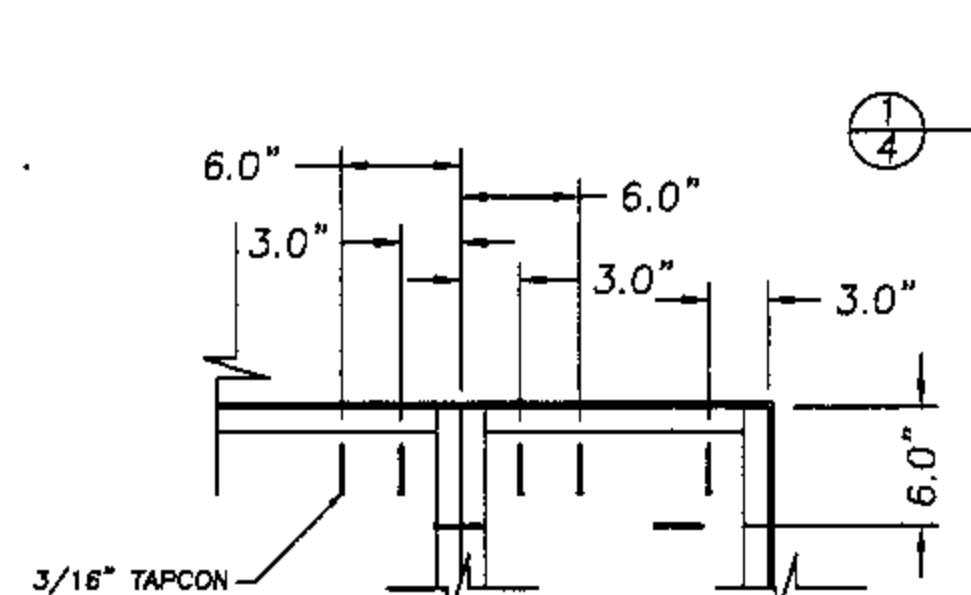

ANCHORING OF SIDELITE THROUGH 1X BUCK

- NOTE:
1. When using a 1X sub-buck a 6-9/16" jamb is required to allow for min. edge spacing for Tapcon type anchors.
  2. A minimum clearance of 2.0" for all anchoring screws to mortar joints must be maintained.

AUGUST 12, 2002  
 Lyndon F. Schmidt  
 Florida P. E. No. 43409  
 19506 French Lace Drive  
 Lutz, FL 33558

**THERMA-TRU CORPORATION**  
 1687 WOODLANDS DRIVE  
 MAUMEE, OHIO  
 PH. (800) 537-8827

ANCHOR CROSS SECTIONS  
 MASONRY 8'0"  
 OUT-SWING WOOD FRAME

**RW** BUILDING  
 CONSULTANTS, INC.  
 813.659.9197

DATE: 7/15/02  
 SCALE: NTS  
 DWG. BY: WLN  
 CHK. BY: RW  
 DRAWING NO.: TT-104-OC  
 SHEET 3 OF 4

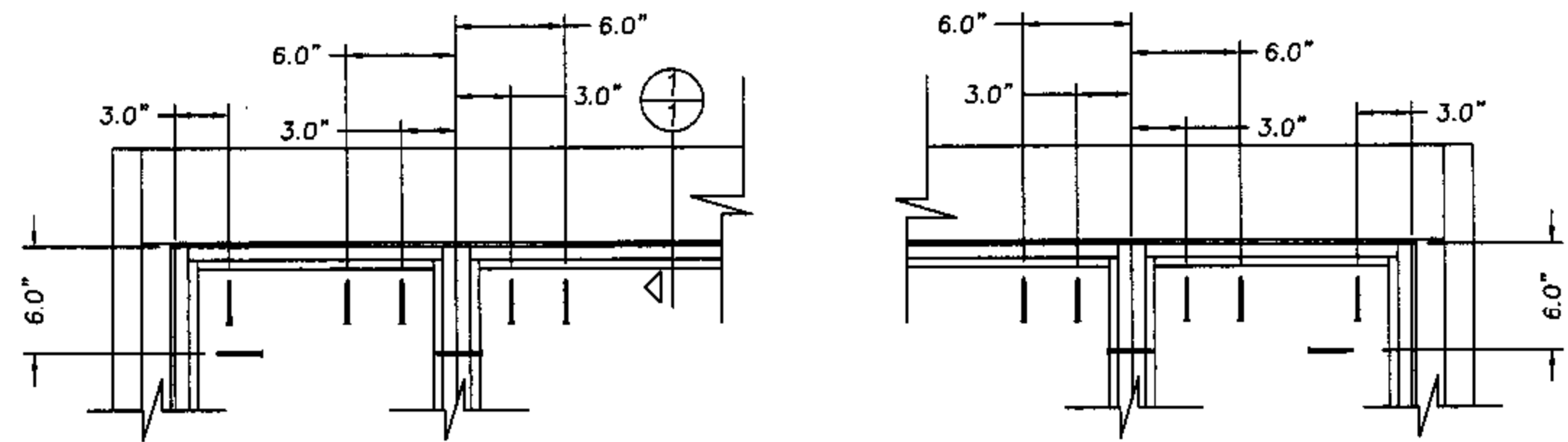
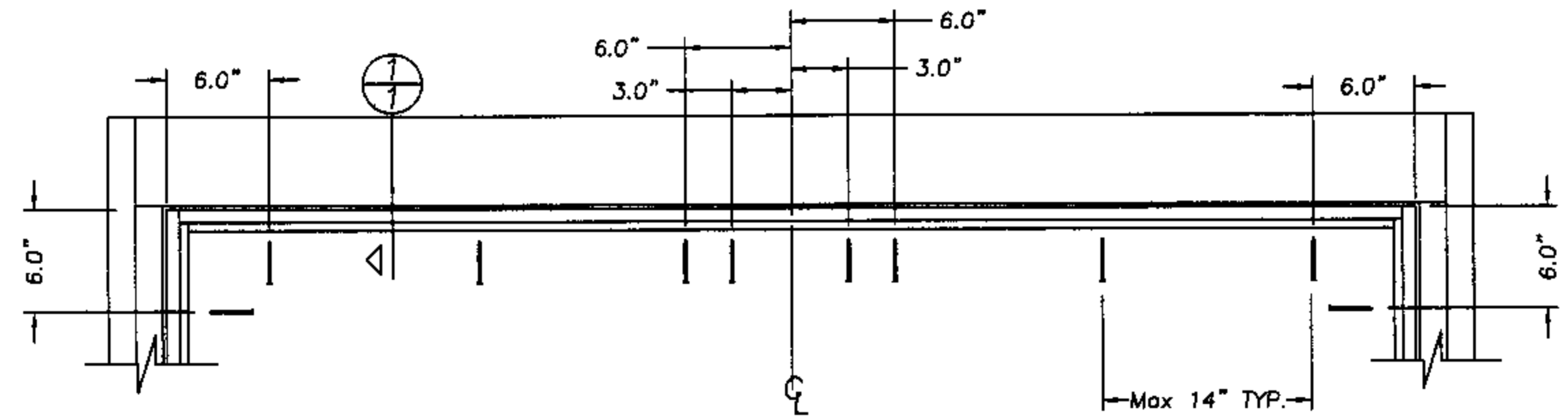
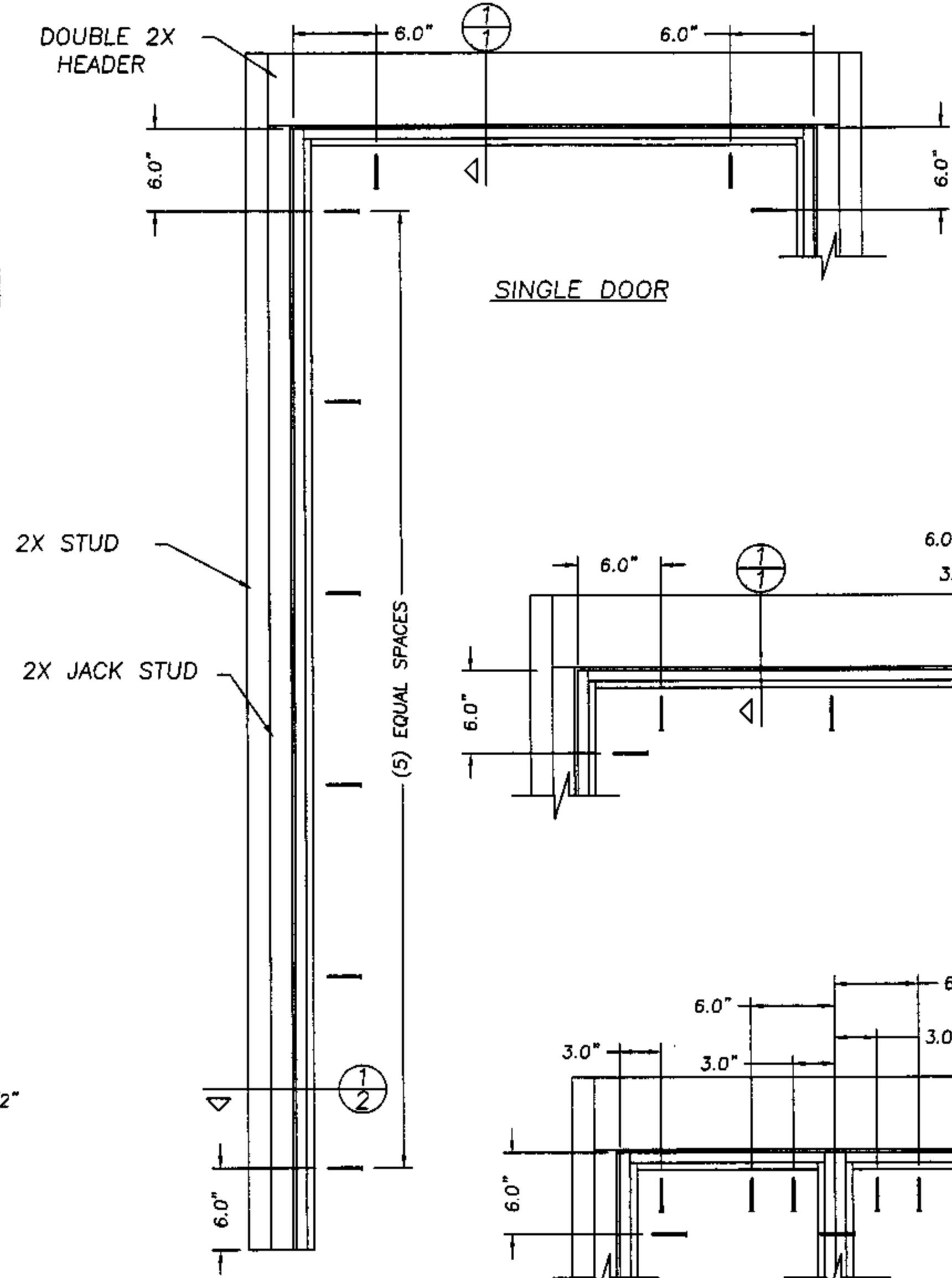
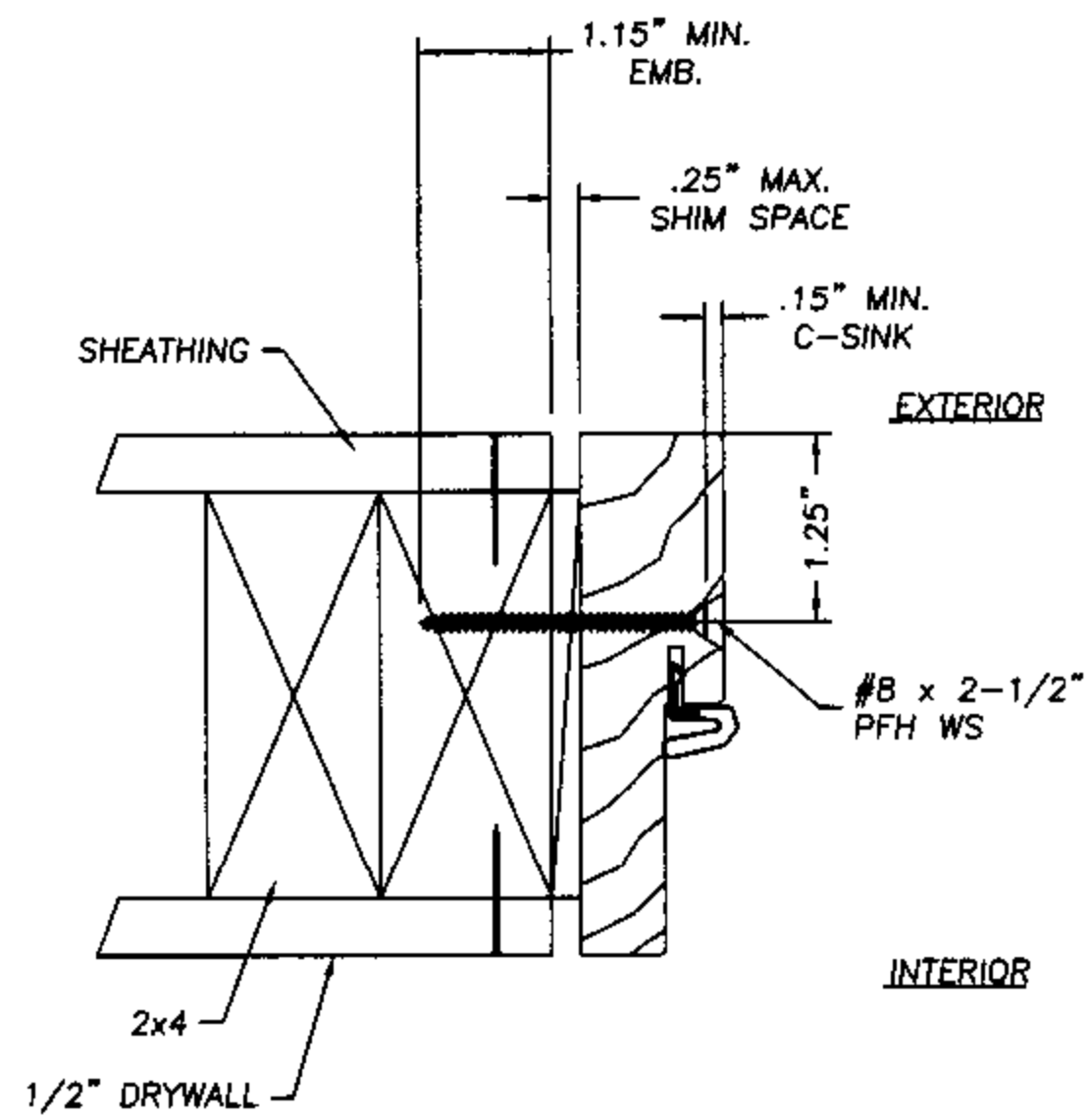
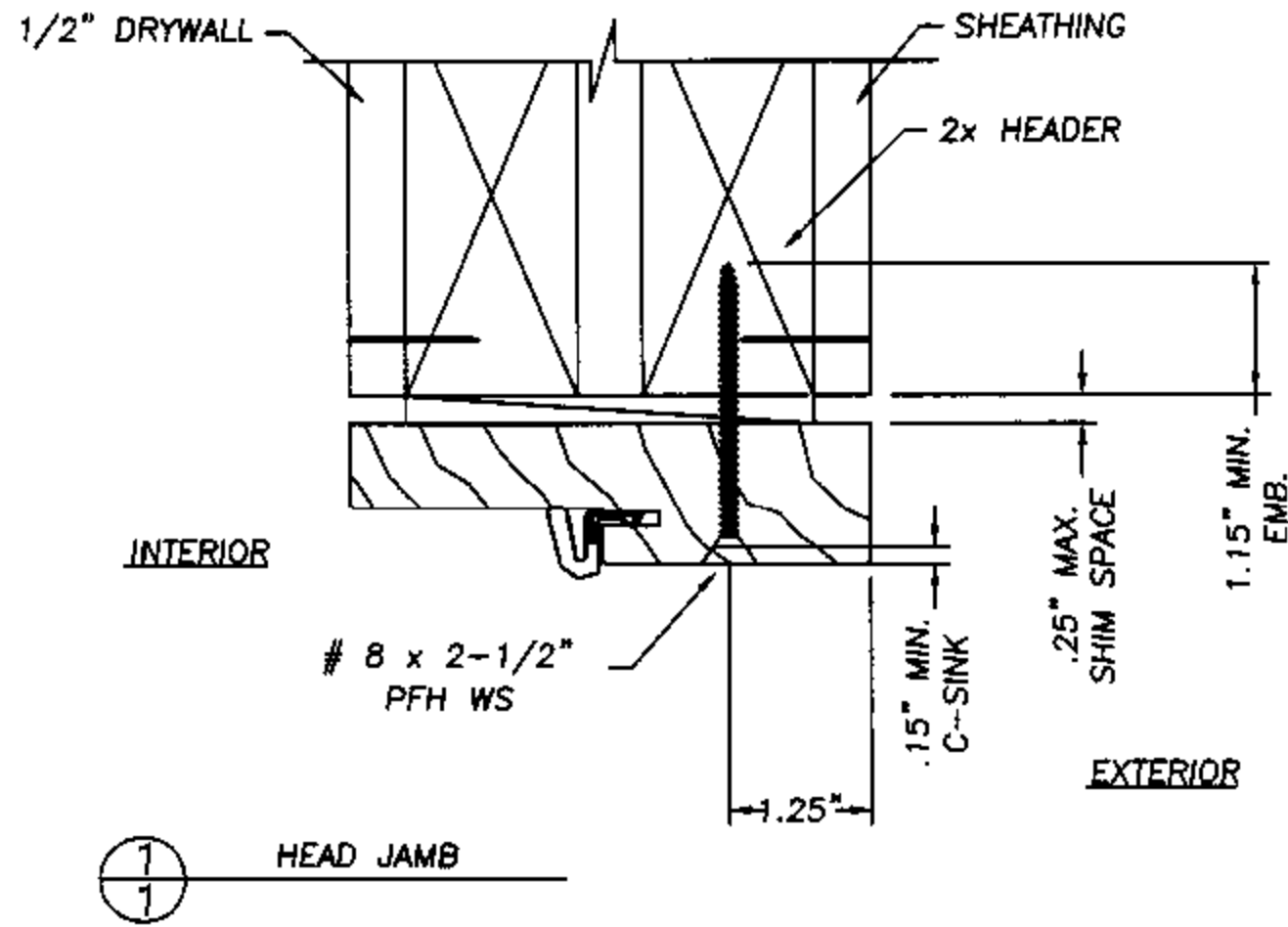

AUGUST 12, 2002  
 Lyndon F. Schmidt  
 Florida P. E. No. 43409  
 19506 French Lace Drive  
 Lutz, FL 33558

**THERMA-TRU CORPORATION**  
 1687 WOODLANDS DRIVE  
 MAUMEE, OHIO  
 PH. (800) 537-8827

ANCHOR CROSS SECTIONS  
 WOOD OR STEEL STUD  
 IN-SWING / OUT-SWING  
 WOOD FRAME

**RW** BUILDING  
 CONSULTANTS, INC.  
 813.659.9197

DATE: 7/15/02  
 SCALE: NTS  
 DWG. BY: WLN  
 CHK. BY: RW  
 DRAWING NO.: TT-104-OC  
 SHEET 4 OF 4