

# American Craftsman Windows

2100 SERIES, MODEL 2160 NAILING FIN  
MULLED SINGLE HUNG EXTRUDED VINYL WINDOW W/ALUMINUM MULLION

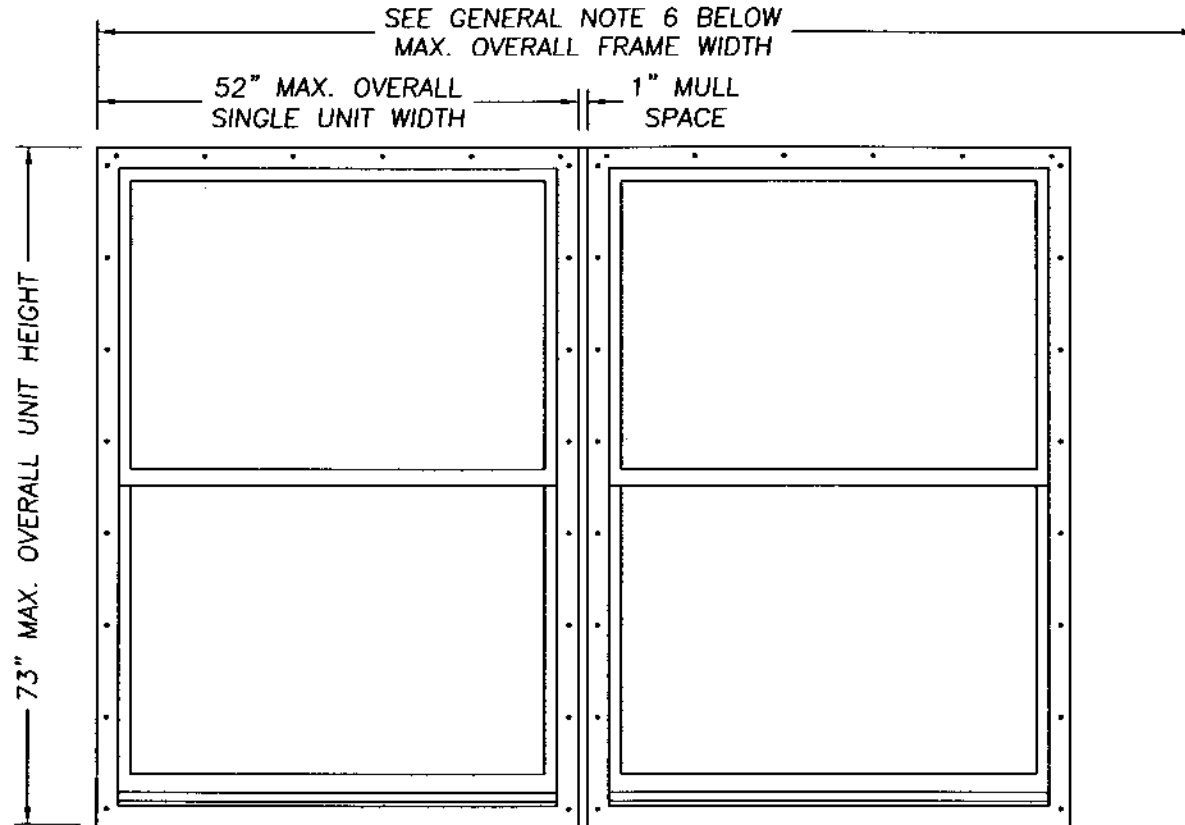

	OVERALL SINGLE UNIT WIDTH	52"	48"	44"	40"	36"
OVERALL UNIT HEIGHT						
73"		+25 -25	+26 -26	+29 -29	+32 -32	+35 -35
72"		+25 -25	+27 -27	+30 -30	+33 -33	+36 -36
68"		+26 -26	+28 -28	+31 -31	+35 -35	+38 -38
64"		+27 -27	+29 -29	+32 -32	+37 -37	+41 -41
62"		+28 -28	+30 -30	+33 -33	+38 -38	+45 -45

## GENERAL NOTES

1. THIS PRODUCT IS DESIGNED TO COMPLY WITH THE FLORIDA BUILDING CODE.
2. PRODUCT ANCHORS SHALL BE AS LISTED AND SPACED AS SHOWN ON DETAILS.
3. WHEN THIS PRODUCT IS USED IN AN AREA REQUIRING WINDBORNE DEBRIS PROTECTION, FLORIDA BUILDING CODE APPROVED IMPACT RESISTANT SHUTTERS ARE REQUIRED.
4. WOOD STUD ANCHORING SEE SHEET 2 OF 3.
5. SEE SHEET 3 OF 3 FOR MULLION DETAILS.
6. DOUBLE UNIT SHOWN IN ELEVATION ABOVE. CAN BE CONFIGURED IN MULTIPLE UNITS. SINGLE UNIT WIDTH CAN NOT EXCEED 52" x 73" IN ANY CONFIGURATION.
7. DESIGN PRESSURE CAN NOT EXCEED +45 (LIMITED BY THE SINGLE UNIT WATER TEST).

## PRODUCT DESCRIPTION

1. VINYL SINGLE HUNG WINDOW WITH MITERED AND WELDED CORNERS.
2. THE HEAD AND SIDE JAMBS ARE EXTRUDED VINYL WITH AN EXTERIOR WALL THICKNESS OF 0.070" +/- 0.008".
3. ALL ACTIVE SASH MEMBERS REINFORCED WITH SOLID ALUMINUM BAR STOCK.
4. THE FIXED MEETING RAIL UTILIZES A ROLLED FORMED STEEL REINFORCEMENT.
5. ALL FRAME MEMBERS HAVE AN INTEGRAL NAILING FIN.
5. ALL UNITS USE SILVERLINE MULLION #2711 AND #2712 MULLION COVER. BOTH THE MULLION AND MULLION COVER ARE EXTRUDED 6063-T6 ALUMINUM.
6. USE SILVERLINE ANCHORING PLATE #2713 0.063" ALUMINUM, (2) PER MULLION.

September 20, 2002  
Lyndon F. Schmidt  
Florida P. E. No. 43409  
19506 French Lace Drive Lutz, FL 33558

American Craftsman Windows  
P O Box 6029  
North Brunswick, NJ 08902  
PH. 800 299-9501

PRODUCT: 2160 MULLED VINYL SINGLE HUNG WINDOW W/ NAILING FIN W/ALUM. MULLION  
PART OR ASSEMBLY:  
TYPICAL ELEVATION, DESIGN PRESSURES & GENERAL NOTES

NO.	DATE	BY	REVISIONS

RW BUILDING CONSULTANTS, INC.  
813.659.9197

DATE: 09/20/02  
SCALE: N.T.S.  
DWG. BY: TJH  
CHK. BY: RW  
DRAWING NO.: AC-418-0C  
SHEET 1 OF 3

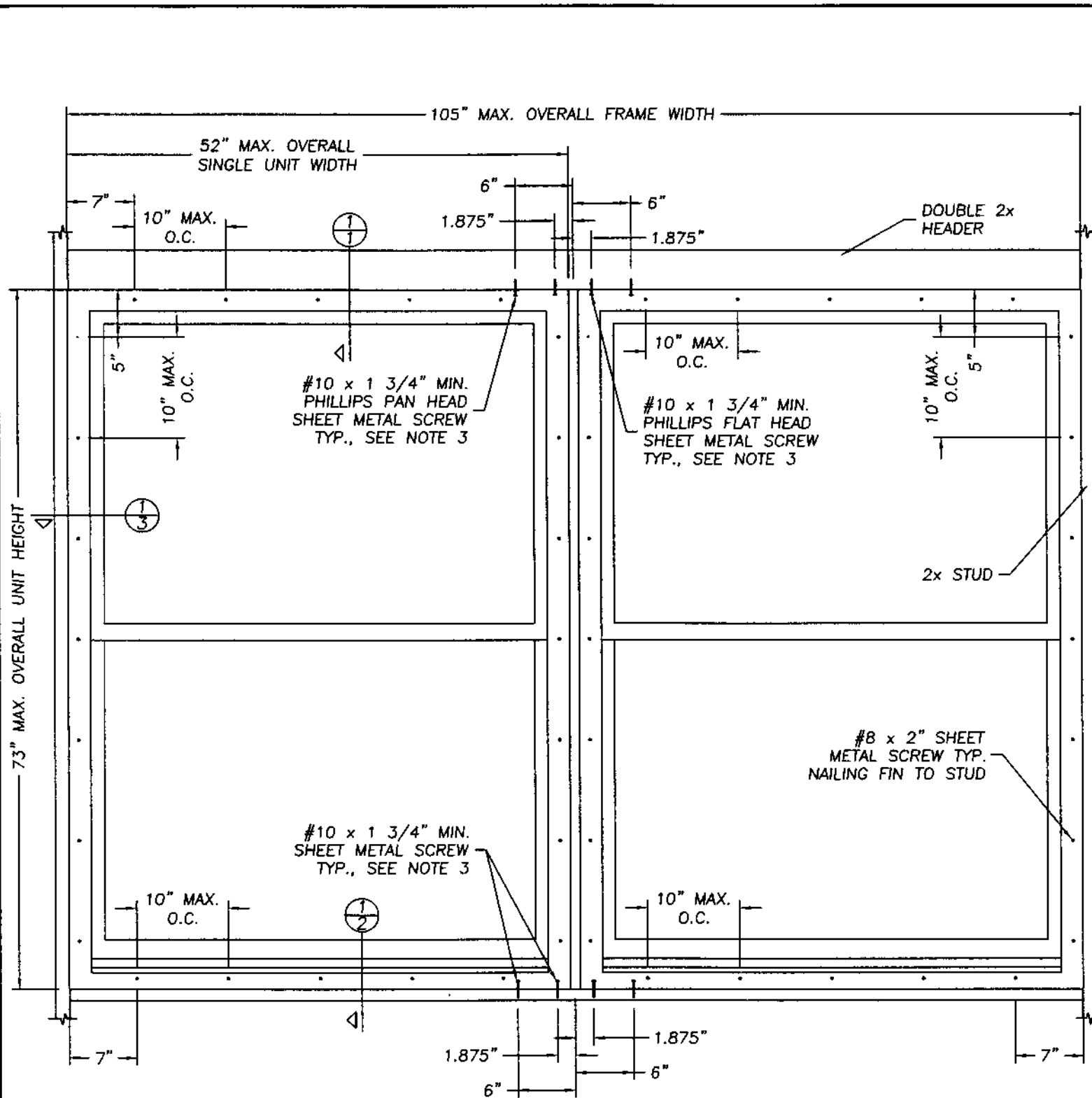

**NOTE:**

1. 15lbs. felt must be used as a water barrier. The felt must cover the nailing fin and anchor screw heads. All loose edges of the felt paper must be sealed with silicone caulk.
2. The full perimeter of the window nailing fin must have a heavy bead of caulk applied to the building side before the window is placed in the opening.
3. The anchor 1.875" from the frame c-line is through the mounting plate. The anchor 6" from the frame c-line is through the window frame.
4. 52" is the maximum single unit width in the mulled application.

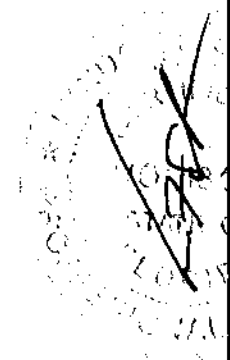
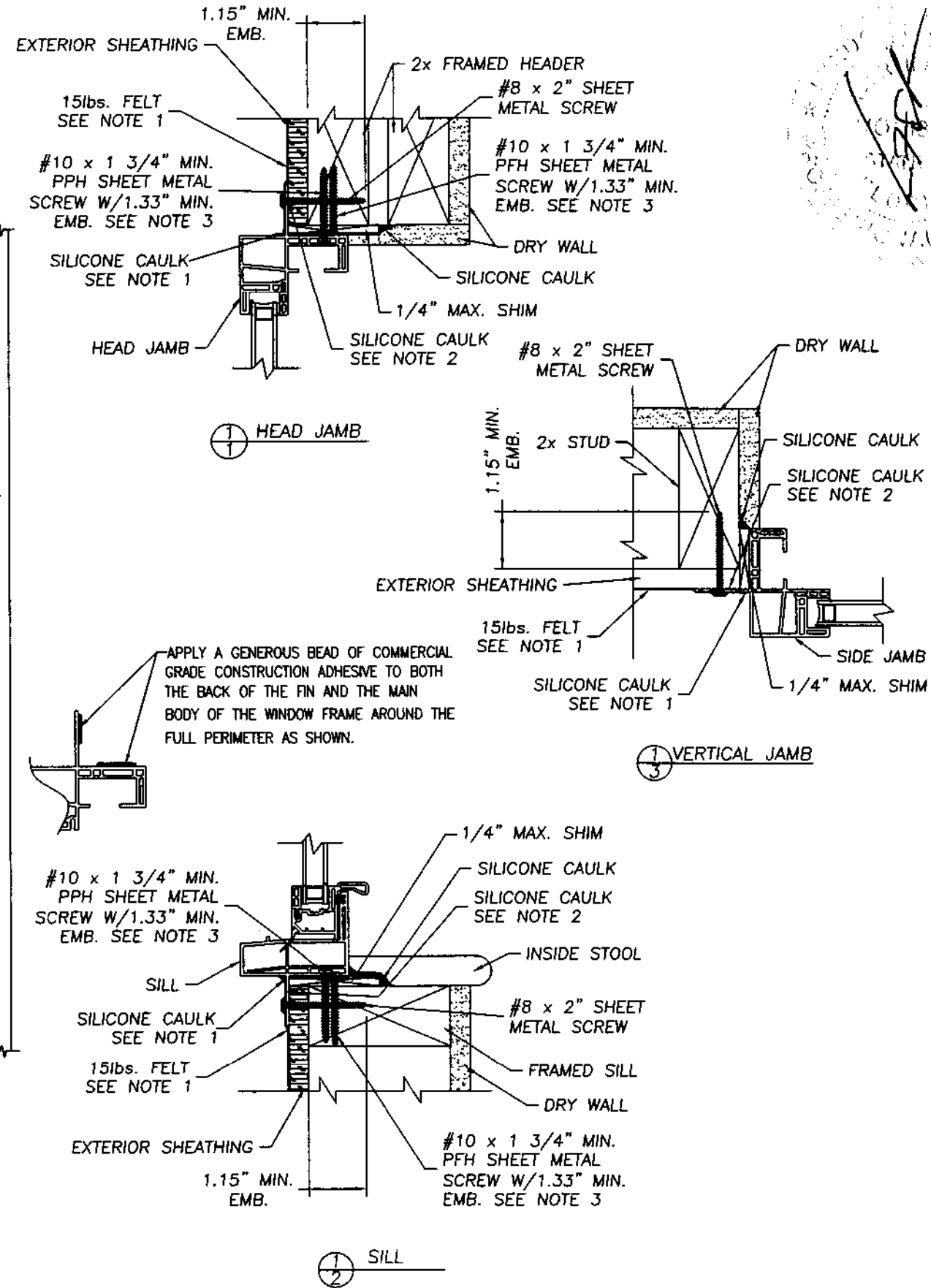

September 20, 2002

Lyndon F. Schmidt  
 Florida P. E. No. 43409  
 19506 French Lace Drive  
 Lutz, FL 33558

American Craftsman Windows  
 P O Box 6029  
 North Brunswick, NJ 08902  
 PH. 800 299-9501

ANCHORING CROSS SECTIONS  
 FOR 2X STUD CONSTRUCTION  
 MODEL 2160 VINYL SINGLE  
 HUNG WINDOW W/ NAILING FIN

**RW** BUILDING  
 CONSULTANTS, INC.  
 813.659.9197

DATE: 09/20/02

SCALE: N.T.S.

DWG. BY: TJH

CHK. BY: RW

DRAWING NO.:

AC-418-OC

SHEET 2 OF 3

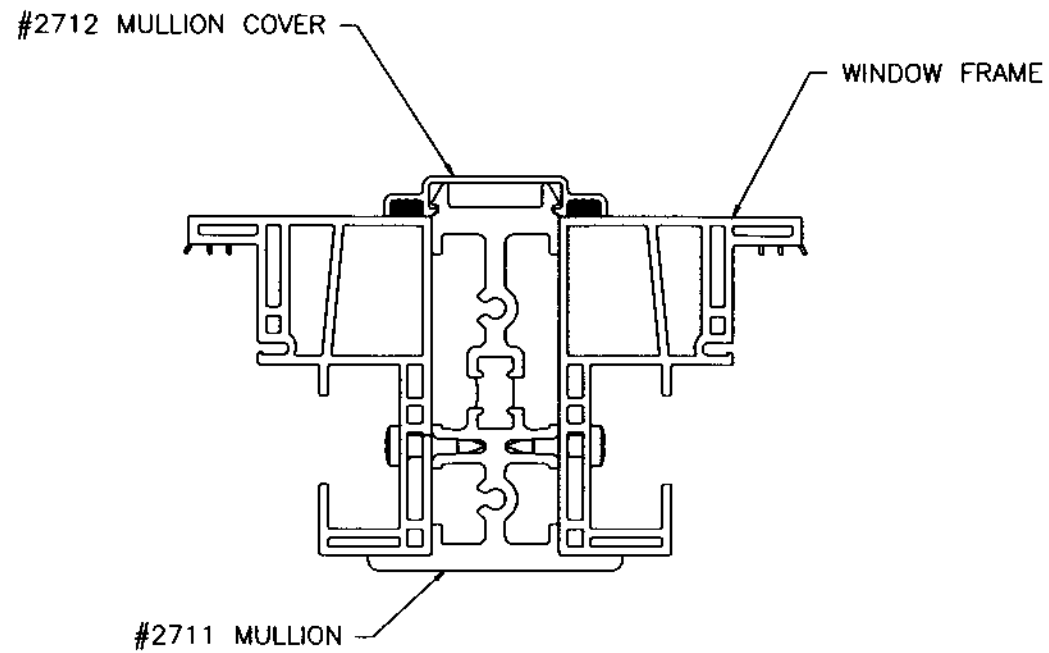

MULLION ASSEMBLY VIEW

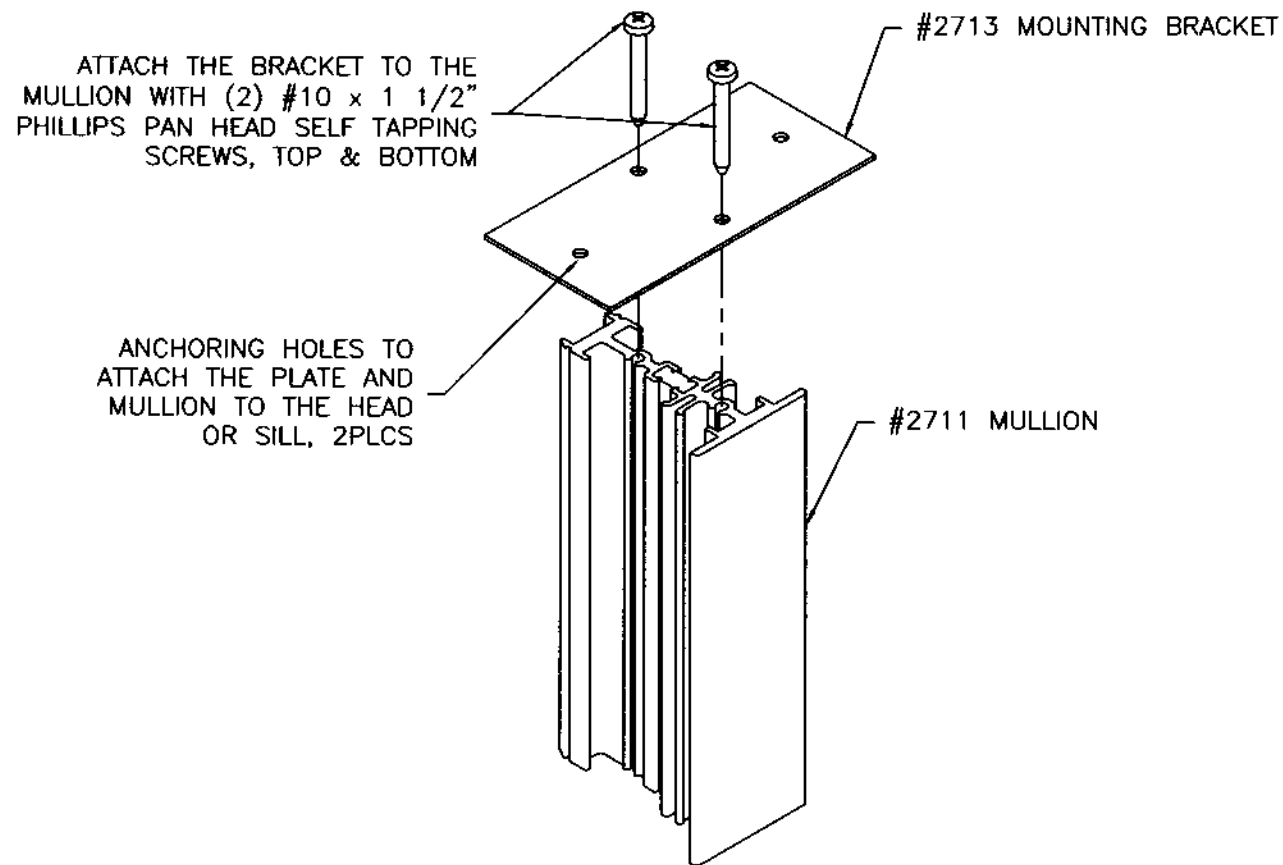
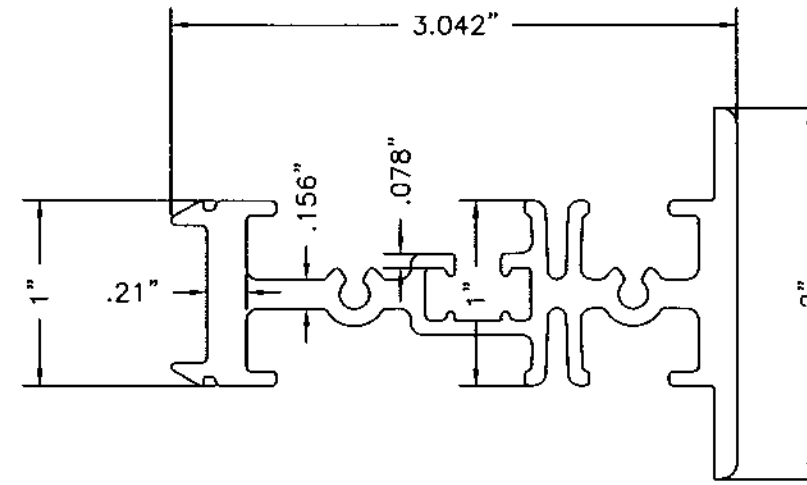
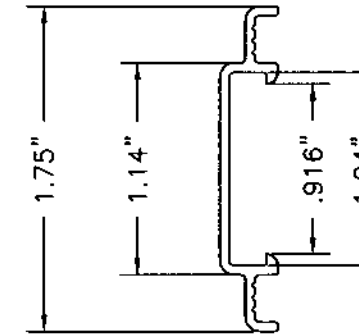

PLATE TO MULLION ATTACHMENT DETAIL



SILVERLINE MULLION #2711  
EXTRUDED ALUMINUM 6063-T6



SILVERLINE MULLION COVER #2712  
EXTRUDED ALUMINUM 6063-T6

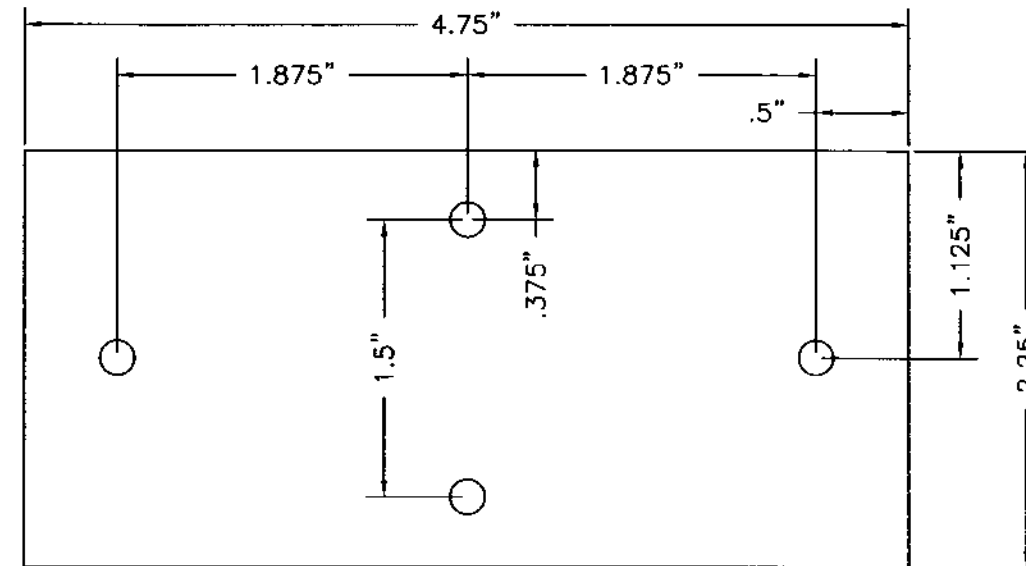

SILVERLINE MULLION MOUNTING BRACKET #2713  
EXTRUDED ALUMINUM 6063-T6 0.063" THK.

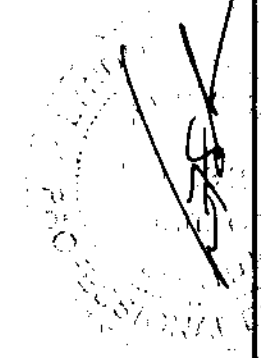

September 20, 2002  
Lyndon F. Schmidt  
Florida P. E. No. 43409  
19506 French Lace Drive  
Lutz, FL 33558

American Craftsman Windows  
P O Box 6029  
North Brunswick, NJ 08902  
PH. 800 299-9501

MODEL 2160 MULLED VINYL  
SINGLE HUNG WINDOW  
W/NAILING FIN  
MULL DETAILS AND ASSEMBLY

**RW** BUILDING  
CONSULTANTS, INC.  
813.659.9197

DATE: 09/20/02

SCALE: N.T.S.

DWG. BY: THJ

CHK. BY: RW

DRAWING NO.:  
AC-418-OC

SHEET 3 OF 3