

CENTRAL FLORIDA B.O.A.F.

MANUFACTURER NAME:

DANVID

MASTER FILE # *3*

8 Hex or Pan Head Woodscrews or
10D Nails with Min.
Imbedment as shown in Tables
(All Way Around)

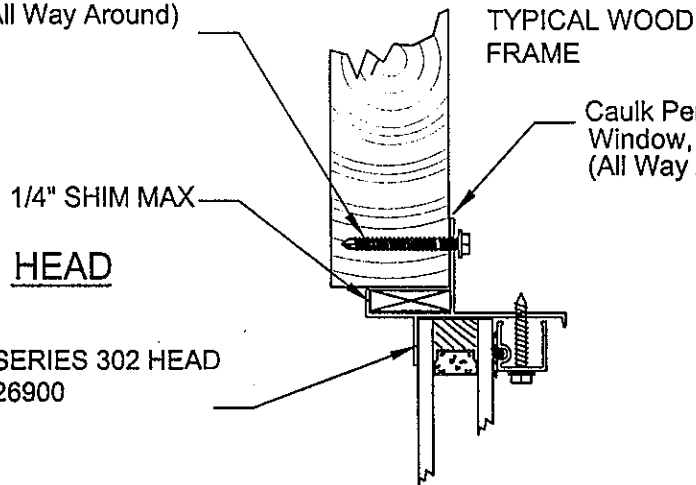

SILL
SECTION 1

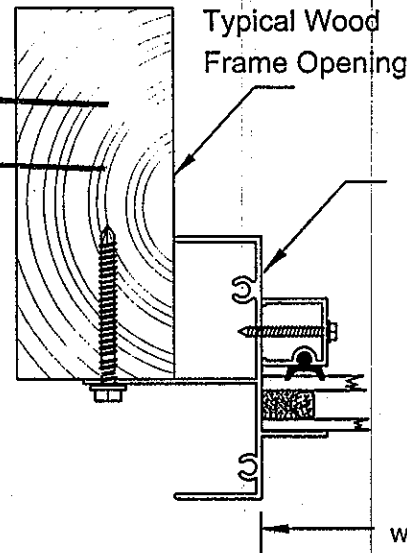

JAMB

OUTSIDE
WINDOW WIDTH

JAMBS
SECTION 2

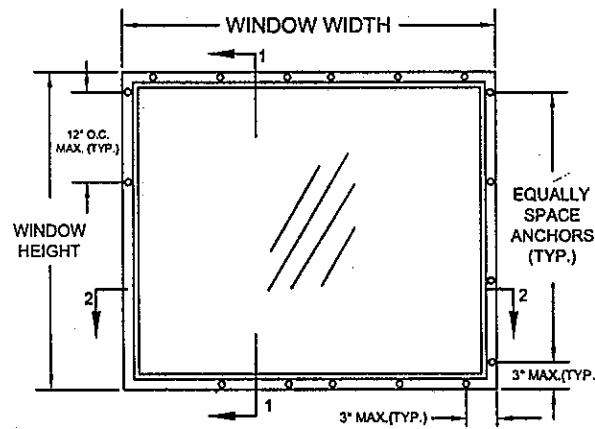

ELEVATION
VIEWED FROM EXTERIOR

YOOSEF LAVI, P.E.
CONSULTING ENGINEER
9550 FOREST LANE, SUITE #108
DALLAS, TEXAS 75243
T: (214)340-0049 F: (214)340-0067

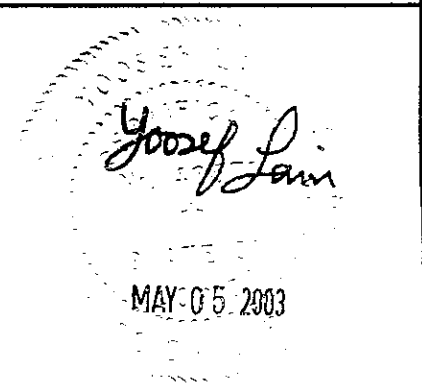

CHANGE	DATE	© DANVID WINDOW COMPANY	
		DANVID WINDOW COMPANY	
		DRAWN ER	DATE 05/05/03
		APPVD	MAT'L
		SCALE Not to Scale	
		FASTENING AND ANCHORAGE INSTALLATIONS 302/2302 SERIES FW	
		A	SHEET 1/2

GENERAL NOTES

- 1) SHIM AS REQ'D. ADJACENT TO EACH INSTALLATION ANCHOR WITH LOAD SHIM MAX. ALLOWABLE SHIM STACK TO BE 1/4".
- 2) WINDOW FRAME MATERIAL ALLOY 6063
- 3) USE LATEX CAULK BEHIND WINDOW FIN AT HEAD, SILL & JAMBS.
- 4) USE LATEX CAULK FOR PERIMETER SEAL AROUND EXTERIOR OF WINDOW FLANGE.
- 5) GLASS THICKNESS MAY VARY PER THE REQUIREMENTS OF ASTM E1300 GLASS CHART
- 6) WHERE WATER RESISTANCE TEST REQUIREMENT OF 15% OF DESIGN LOAD APPLIES, POSITIVE DESIGN LOADS WILL BE LIMITED TO 40.0 PSF DUE TO WATER TEST PRESSURE OF 6.0 PSF ACHIEVED IN TEST.
- 7) INSTALLATION: FIN FRAME WINDOW IN SPRUCE PINE FIR (SPF) WOOD FRAME OPENING WITH TWO BY WOOD STUDS USING 0.128" DIA. NAILS OR #8 SCREW OF SUFFICIENT LENGTH TO PROVIDE MIN EMBEDMENT INTO SUBSTRATE AS SHOWN
- 8) IF EXACT WINDOW SIZE IS NOT LISTED IN ANCHOR CHART, USE ANCHOR QUANTITY IN TABLES.

YOUSEF LAVI, P.E.
 CONSULTING ENGINEER
 9550 FOREST LANE, SUITE #108
 DALLAS, TEXAS 75243
 T: (214)340-0049 F: (214)340-0067

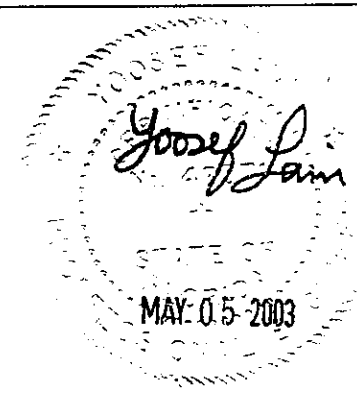

FIXED WINDOW ANCHOR CHART FOR DANVID WINDOW COMPANY SERIES 302/2302 DESIGN PRESSURE 50 PSF						
WINDOW SIZE (INCHES)	NO. OF #8 SCREWS REQUIRED IN FRAME 1" MIN. EMBEDMENT			NO. OF 0.128" DIA. NAILS REQUIRED IN FRAME 1 1/2" MIN. EMBEDMENT		
	WIDTH/HEIGHT	HEAD	SILL	AT EACH JAMB	HEAD	SILL
12 X 12	2	2	2	2	2	2
12 X 18	2	2	2	2	2	2
12 X 24	2	2	2	2	2	2
12 X 30	2	2	2	2	2	2
12 X 36	2	2	2	2	2	2
12 X 44	2	2	2	2	2	2
12 X 48	2	2	2	2	2	2
12 X 60	2	2	2	2	2	3
12 X 72	2	2	2	2	2	3
18 X 12	2	2	2	2	2	2
18 X 18	2	2	2	2	2	2
18 X 24	2	2	2	2	2	2
18 X 30	2	2	2	2	2	2
18 X 36	2	2	2	2	2	2
18 X 44	2	2	2	2	2	3
18 X 48	2	2	2	2	2	3
18 X 60	2	2	2	2	2	4
18 X 72	2	2	2	2	2	5
24 X 12	2	2	2	2	2	2
24 X 18	2	2	2	2	2	2
24 X 24	2	2	2	2	2	2
24 X 30	2	2	2	2	2	2
24 X 36	2	2	2	2	2	3
24 X 44	2	2	2	2	2	3
24 X 48	2	2	2	2	2	4
24 X 60	2	2	2	2	2	5
24 X 72	2	2	2	2	2	6
30 X 12	2	2	2	2	2	2
30 X 18	2	2	2	2	2	2
30 X 24	2	2	2	2	2	2
30 X 30	2	2	2	2	2	2
30 X 36	2	2	2	2	2	3
30 X 44	2	2	2	2	2	4
30 X 48	2	2	2	2	2	4
30 X 60	2	2	2	2	2	5
30 X 72	2	2	3	2	2	7

FIXED WINDOW ANCHOR CHART FOR DANVID WINDOW COMPANY SERIES 302/2302 DESIGN PRESSURE 50 PSF						
WINDOW SIZE (INCHES)	NO. OF #8 SCREWS REQUIRED IN FRAME 1" MIN. EMBEDMENT			NO. OF 0.128" DIA. NAILS REQUIRED IN FRAME 1 1/2" MIN. EMBEDMENT		
	WIDTH/HEIGHT	HEAD	SILL	AT EACH JAMB	HEAD	SILL
36 X 12	2	2	2	2	2	2
36 X 18	2	2	2	2	2	2
36 X 24	2	2	2	3	3	2
36 X 30	2	2	2	3	3	2
36 X 36	2	2	2	3	3	3
36 X 44	2	2	2	3	3	4
36 X 48	2	2	2	3	3	4
36 X 60	2	2	2	3	3	6
36 X 72	2	2	3	3	3	8
44 X 12	2	2	2	2	2	2
44 X 18	2	2	2	3	3	2
44 X 24	2	2	2	3	3	2
44 X 30	2	2	2	4	4	2
44 X 36	2	2	2	4	4	3
44 X 44	2	2	2	4	4	4
44 X 48	2	2	2	4	4	5
44 X 60	2	2	3	4	4	7
44 X 72	2	2	3	4	4	8
48 X 12	2	2	2	2	2	2
48 X 18	2	2	2	3	3	2
48 X 24	2	2	2	4	4	2
48 X 30	2	2	2	4	4	2
48 X 36	2	2	2	4	4	3
48 X 44	2	2	2	5	5	4
48 X 48	2	2	2	5	5	5
48 X 60	2	2	3	5	5	7
48 X 72	2	2	4	5	5	9

CHANGE	DATE	DANVID WINDOW COMPANY		DANVID WINDOW COMPANY	
		DRAWN ER		DATE 05/05/03	APPVD
		ANCHOR CHART FOR 302/2302 SERIES FW		MAT'L	SCALE Not to Scale
		A		SHEET 2/2	