

SEARS HOME IMPROVEMENT PRODUCTS

7000 SERIES (AS MFG. BY SIMONTON SERIES 08-08)
EXTRUDED VINYL CASEMENT WINDOWS

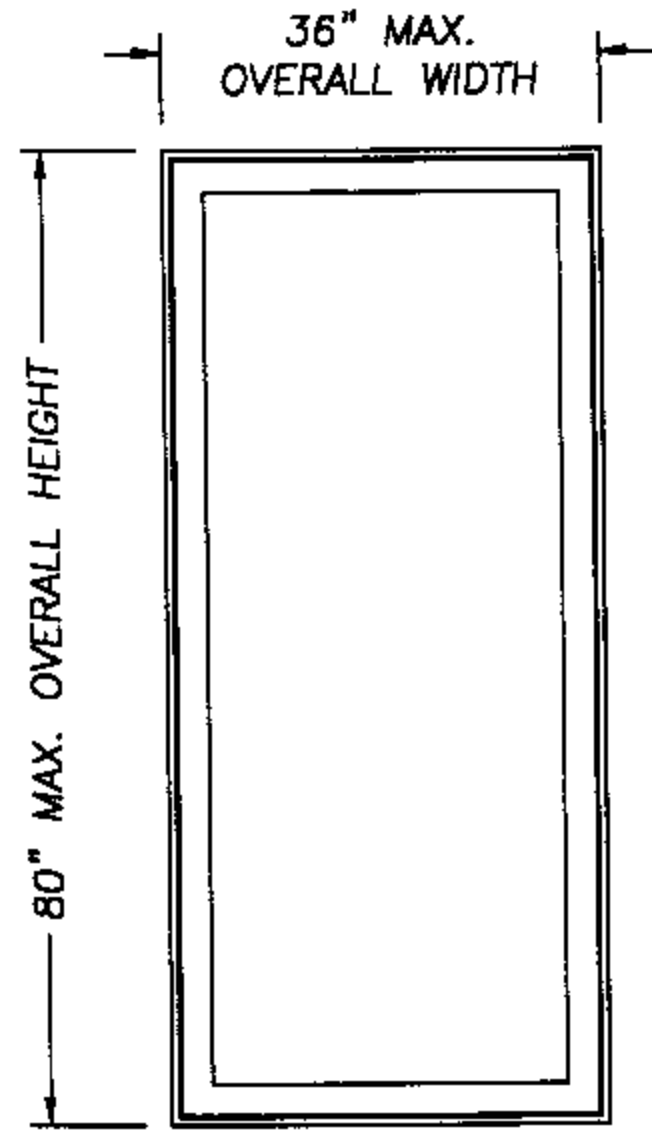

X

DESIGN PRESSURE RATING
POS. 55.0 NEG. 55.0
3/4" INSULATED GLASS
3/16" ANN. - AIR SPACE - 3/16" ANN.

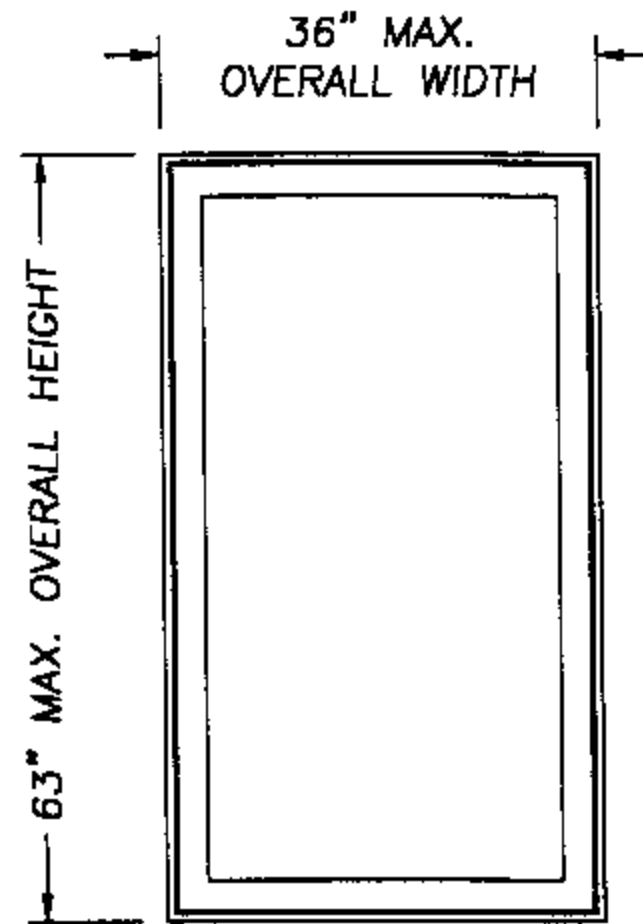

X

DESIGN PRESSURE RATING
POS. 45.0 NEG. 45.0
3/4" INSULATED GLASS
1/8" ANN. - AIR SPACE - 1/8" ANN.

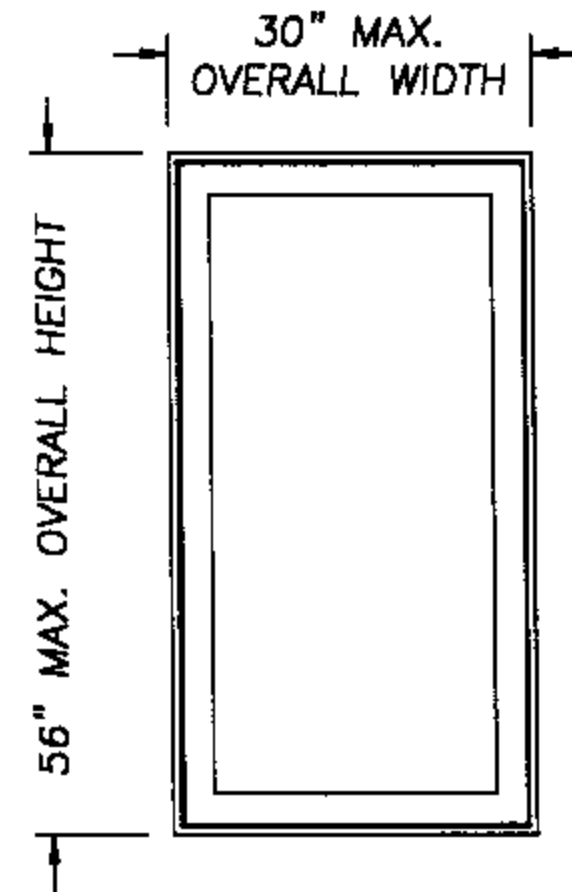

X

DESIGN PRESSURE RATING
POS. 55.0 NEG. 55.0
3/4" INSULATED GLASS
1/8" ANN. - AIR SPACE - 1/8" ANN.

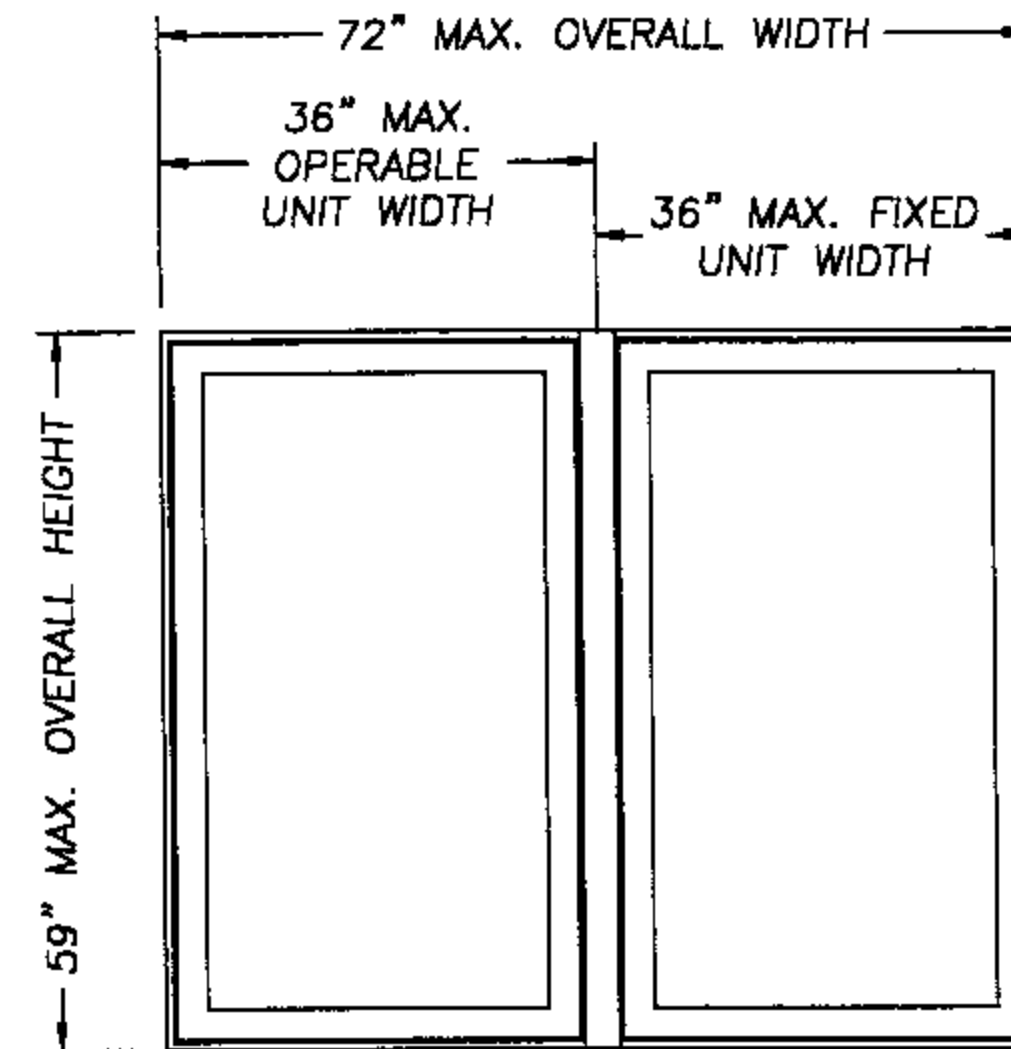

X

O

DESIGN PRESSURE RATING
POS. 50.0 NEG. 50.0
3/4" INSULATED GLASS
3/16" ANN. - AIR SPACE - 3/16" ANN.

DESIGN PRESSURE RATING
OVERALL SIZE 52" x 59"
POS. 50.0 NEG. 50.0
3/4" INSULATED GLASS
1/8" ANN. - AIR SPACE - 1/8" ANN.

GENERAL NOTES

- THIS PRODUCT IS DESIGNED TO COMPLY WITH THE FLORIDA BUILDING CODE.
- PRODUCT ANCHORS SHALL BE AS LISTED AND SPACED AS SHOWN ON DETAILS.
- WHEN THIS PRODUCT IS USED IN AN AREA REQUIRING WINDBORNE DEBRIS PROTECTION, FLORIDA BUILDING CODE APPROVED IMPACT RESISTANT SHUTTERS ARE REQUIRED.
- SINGLE CASEMENT ANCHORING TO EXISTING OPENING W/ EXISTING 1X BUCK STRIP TO MASONRY SEE SHEET 2 OF 3.
- MULLED CASEMENT ANCHORING TO EXISTING OPENING W/ EXISTING 1X BUCK STRIP TO MASONRY SEE SHEET 3 OF 3.

PRODUCT DESCRIPTION

- VINYL CASEMENT WINDOW WITH MITERED AND WELDED CORNERS.
- THE HEAD AND SIDE JAMBS ARE EXTRUDED VINYL WITH AN EXTERIOR WALL THICKNESS OF 0.070".
- ALL FRAME PROFILES ALLOW OPTIONAL INSIDE AND OUTSIDE USE OF UV09 SNAP TRIM.
- INTEGRAL "T" MULLIONS WERE REINFORCED WITH CUSTOM SHAPED ALUMINUM EXTRUSION.

 JULY 29, 2002
 Lyndon F. Schmidt
 Florida P. E. No. 43409
 19506 French Lace Drive Lutz, FL 33558

Sears Home Improvement Products
 1024 Florida Central Parkway
 Longwood, FL 32750
 PH. 800.222.5030
 Fax. 407.352.8216



PRODUCT:	SEARS EXTRUDED VINYL CASEMENT WINDOW		
PART OR ASSEMBLY:	GENERAL NOTES & TYPICAL ELEVATIONS		
NO.	DATE	BY	REVISIONS

 RW BUILDING
 CONSULTANTS, INC.
 813.659.9197

DATE: 6/21/02

SCALE: N.T.S.

OWG. BY: WLN

CHK. BY: RW

DRAWING NO.:
SR-104-OC

SHEET 1 OF 3

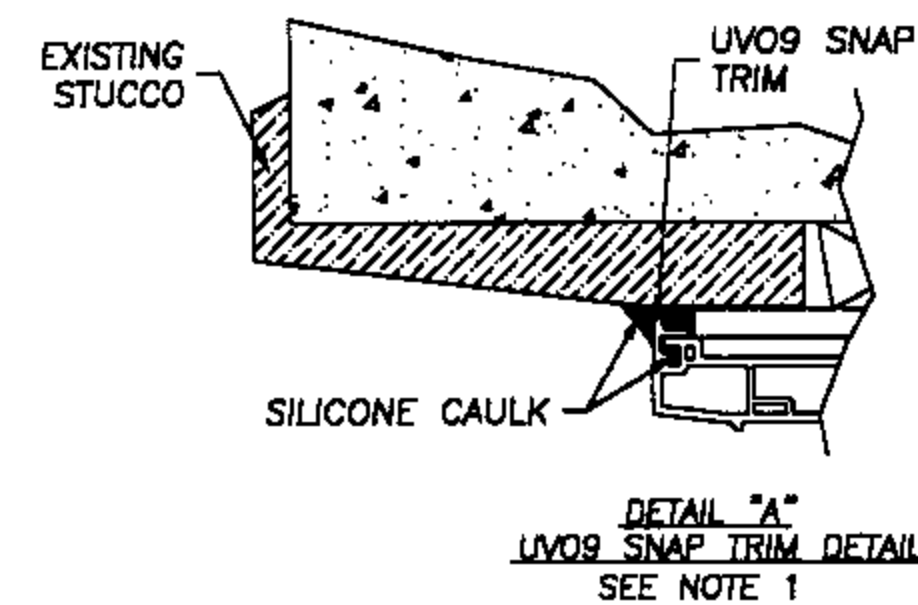
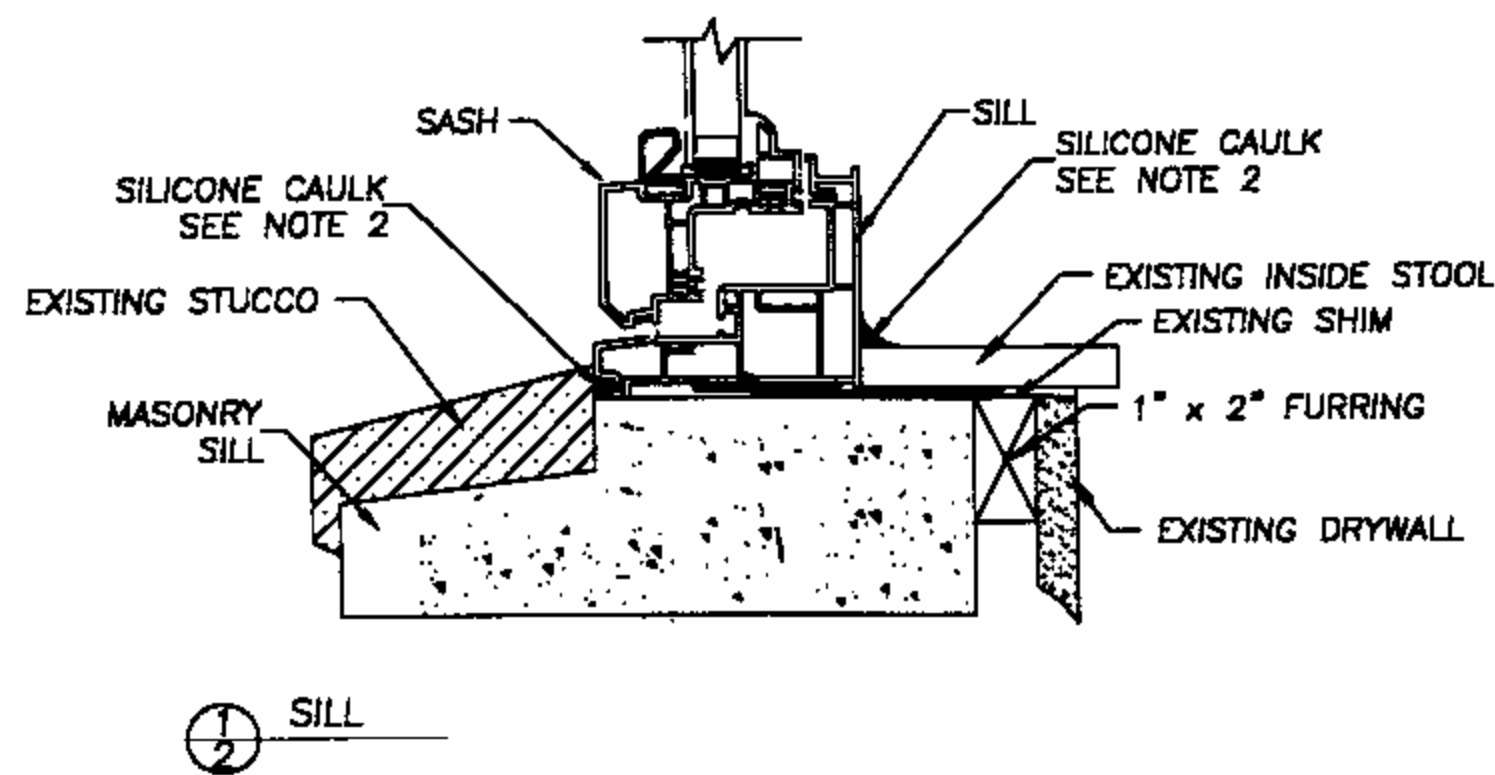
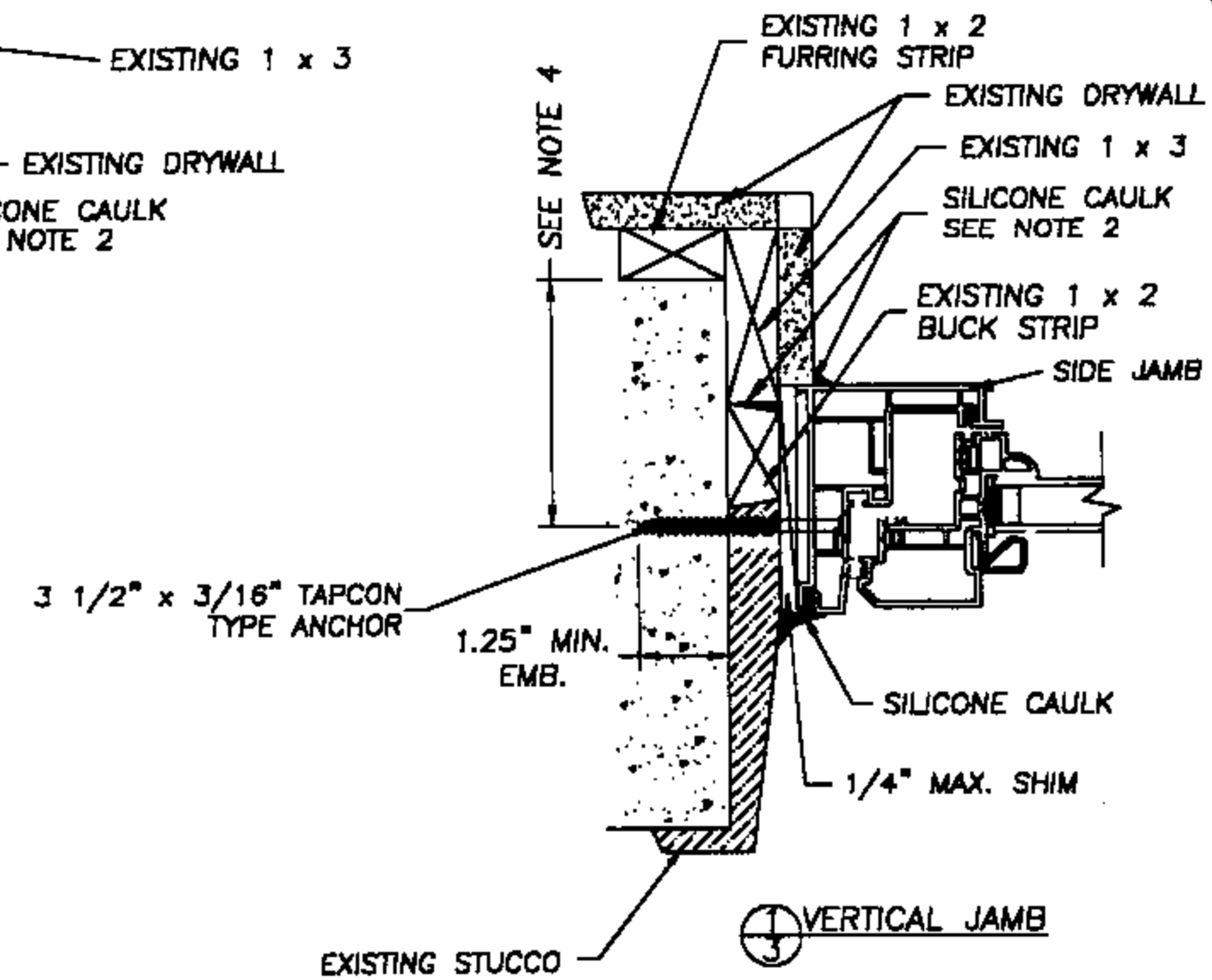
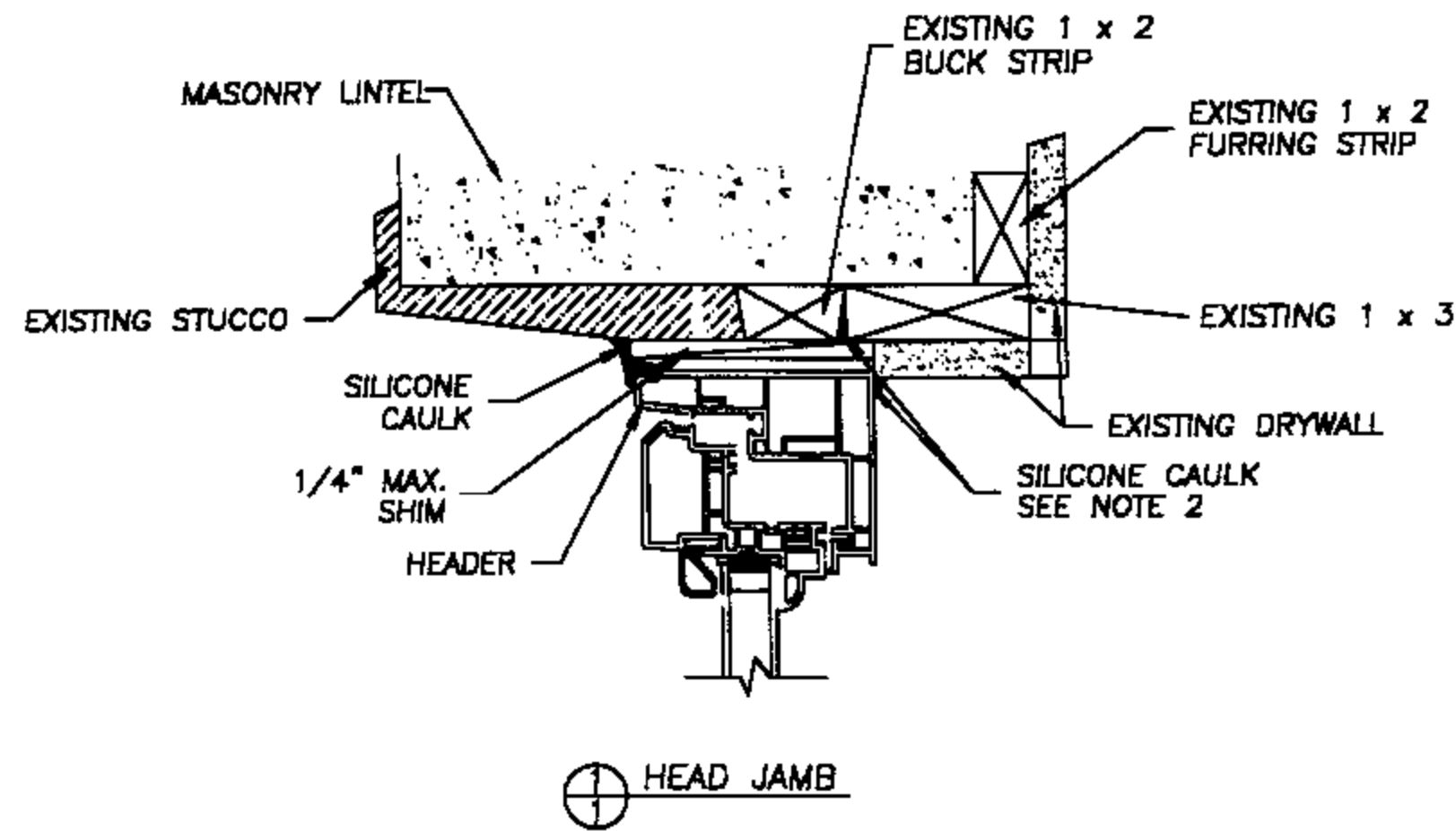
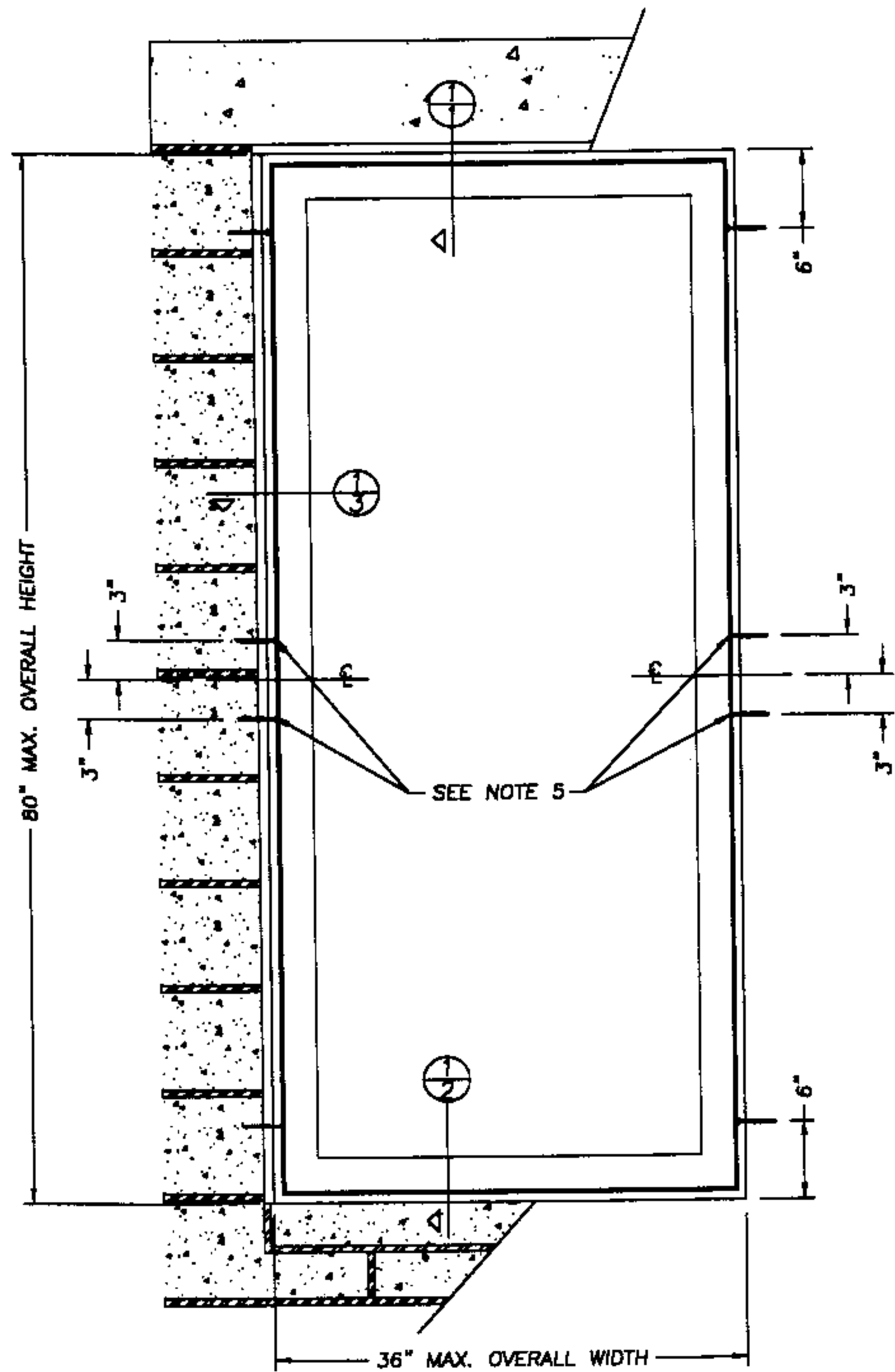

NOTE:

1. The UVO9 Snap Trim is used as needed for cosmetic trim only on the head and side jambs. The trim groove on the frame must be filled with silicone before the trim is snapped into place.
2. All interior and exterior perimeter surfaces of the window must be caulked. Caulk between existing 1 x 2 buck strip and existing 1 x 3.
3. Adjust Tapcon anchor locations, if necessary, to maintain a minimum 2.0" clearance from mortar joints.
4. A minimum clearance of 2.0" from face of masonry must be maintained.
5. When installing a window below 30" in height the center screws are eliminated. When installing a window 30" to 60" in height use (1) screw at the frame center line. When installing a window above 60" to 74" in height anchor as shown with (1) screw 3" above and below the frame center line.

JULY 29, 2002

Lyndon F. Schmidt
Florida P. E. No. 43409
19506 French Lace Drive
Lutz, FL 33558

Sears Home Improvement Products

1024 Florida Central Parkway
Longwood, FL 32750
PH. 800.222.5030
Fax. 407.332.8216



ANCHORING CROSS SECTIONS
EXISTING OPENING W/EXISTING
1X BUCK STRIP TO MASONRY
VINYL SINGLE CASEMENT

RW BUILDING
CONSULTANTS, INC.
813.659.9197

DATE: 06/21/02

SCALE: N.T.S.

DWG. BY: WLN

CHK. BY: RW

DRAWING NO.:

SR-104-OC

SHEET 2 OF 3

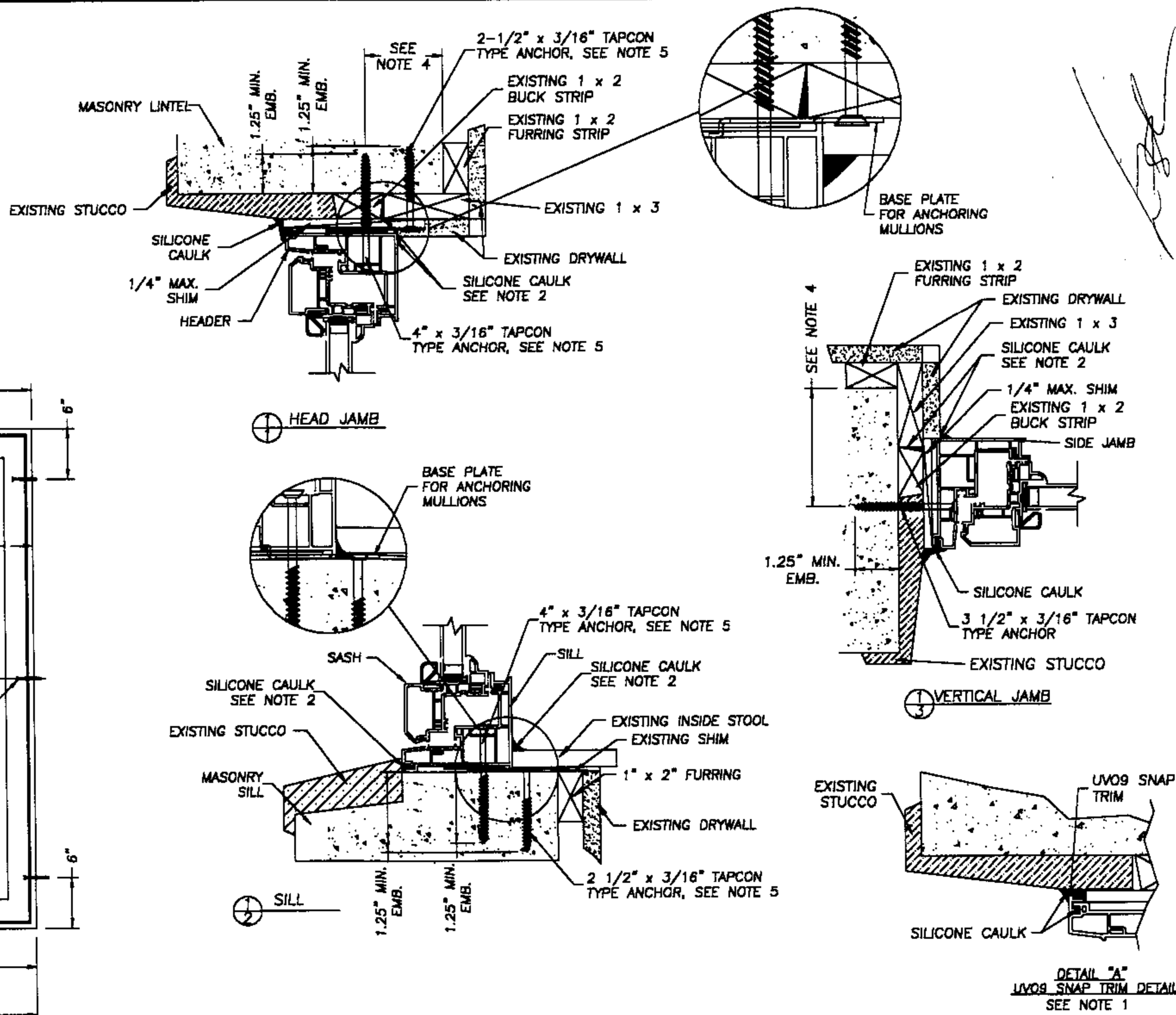
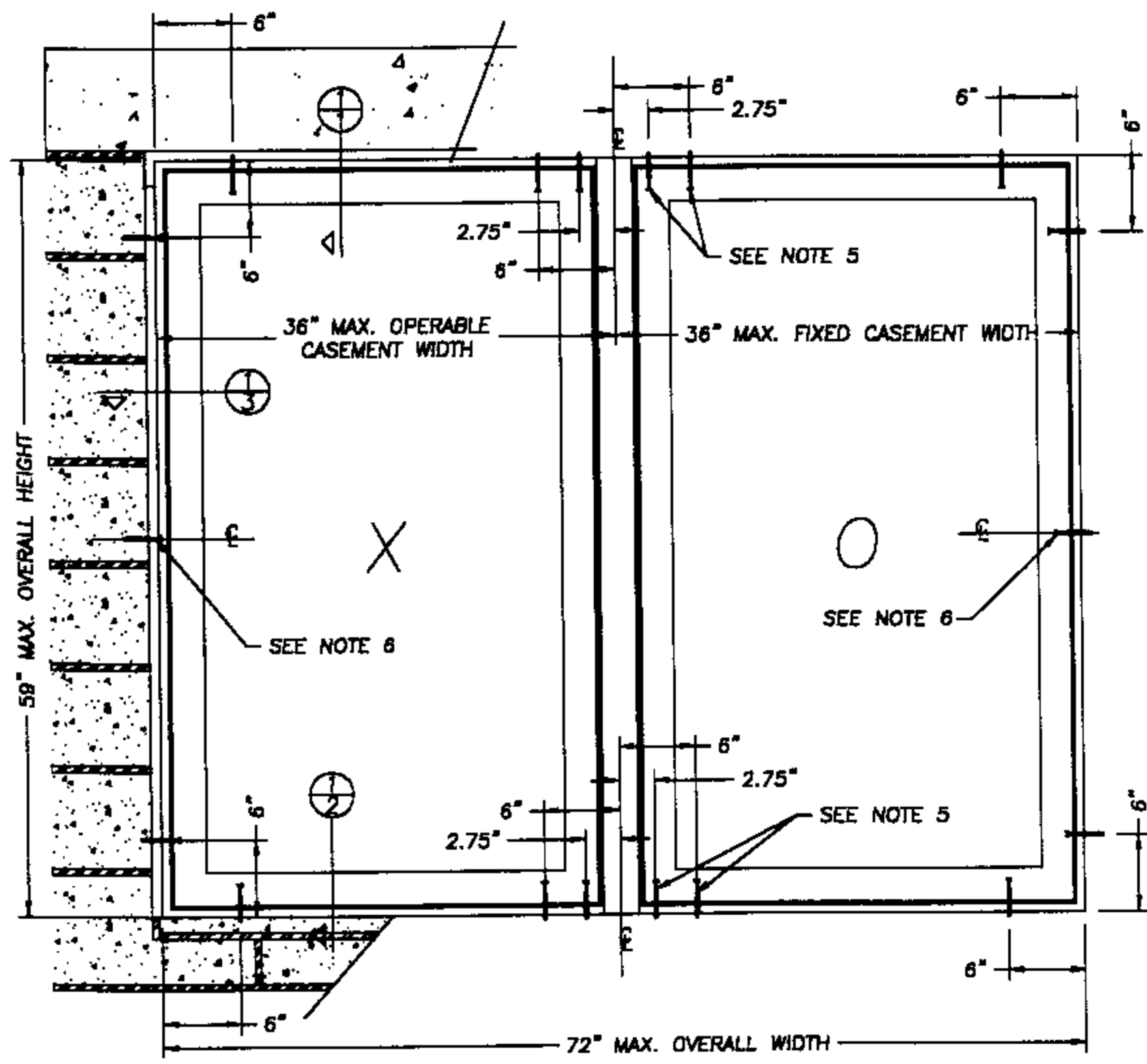

NOTE:

1. The UV09 Snap Trim is used as needed for cosmetic trim only on the head and side jambs. The trim groove on the frame must be filled with silicone before the trim is snapped into place.
2. All interior and exterior perimeter surfaces of the window must be caulked. Caulk between existing 1 x 2 filler strip and existing 1 x 3 buck.
3. Adjust Tapcon anchor locations, if necessary, to maintain a minimum 2.0" clearance from mortar joints.
4. A minimum clearance of 2.0" from face of masonry must be maintained.
5. The anchor screw at 2.75" from the mullion center is through the mullion anchoring plate. The anchor screw at 6" from the mullion center is through the window frame.
6. When installing a window below 30" in height the center screw is eliminated. When installing a window 30" to 59" in height use (1) screw at the frame center line.

JULY 29, 2002
 Lyndon F. Schmidt
 Florida P. E. No. 43409
 19506 French Lace Drive
 Lutz, FL 33558

Sears Home Improvement Products
 1024 Florida Central Parkway
 Langwood, FL 32750
 PH. 800.222.5030
 Fax. 407.332.8216

ANCHORING CROSS SECTIONS
 EXISTING OPENING W/EXISTING
 1X BUCK STRIP TO MASONRY
 VINYL TWIN CASEMENT

RW BUILDING CONSULTANTS, INC.
 813.659.9197

DATE: 06/21/02
 SCALE: N.T.S.
 DWG. BY: TJH
 CHK. BY: RW
 DRAWING NO.: SR-104-OC
 SHEET 3 OF 3